

HEATH & ASSOCIATES

Transportation Planning & Engineering

TRAFFIC IMPACT ANALYSIS

The Pinnacle at Liberty Bay

Poulsbo, Washington

April 2026

1011 E Main Ave Suite 453 | Puyallup, WA | 98372
(253) 770-1401 | heathtraffic.com

THE PINNACLE AT LIBERTY BAY TRAFFIC IMPACT ANALYSIS

Prepared for:

Montebanc Management, LLC
c/o Paul Devenzio, Chip McBroom

Prepared by:

Heath & Associates
PO Box 397
Puyallup, WA 98371
(253) 770 1401
Heathtraffic.com

License:



4/9/2026



Date: March 26, 2026

To: Michael Bateman, City of Poulsbo

From: Andrew L. Bratlien, P.E., PTOE
Heath & Associates

Subject: The Pinnacle at Liberty Bay TIA Comment Response

This memorandum provides responses to the comments provided by the City of Poulsbo and Parametrix as identified in the September 8, 2025 memorandum "Review for The Pinnacle at Liberty Bay Traffic Impact Analysis (TIA)." The enclosed TIA has been updated based on the March 2026 site plan, including a revised layout consisting of 138 dwelling units

1. COMMENT RESPONSES

Parametrix numbered comments and associated responses are provided below.

Comment #1: Page 8: SR 305 speed is 40 mph north of ~Baywatch Court and 50 mph south of that location.

Response #1: TIA Table 1 has been updated.

Comment #2: Page 10: AM and PM peaks are noted as generally occurring between 7-8 AM and 5-6 PM. Do any of the study intersections have local peaks that are substantially (>30 minutes) outside of the system peaks?

Response #2: TIA language has been refined and a table has been added to identify AM and PM peak hour for each intersection.

Comment #3: Page 10: Verify how the AM school traffic was accounted for. Was there a decrease in PHF to account for the 15-minute spike or some other method?

Response #3: AM peak hour traffic counts captured school peaking effects via PHF which was applied to the existing and future conditions intersection operations analysis. Existing PHFs are documented in the traffic count sheets.



Comment #4: ~Pages 10-16: Clarify which study intersections are reporting performance metrics. There appears to be variability in what is reported for study intersections, for example:

- Section 3.4 lists out 5 intersections where counts were collected and mentions 2 other intersections where counts were estimated.
- Figures 3-4 show 6 of the 7 intersections mentioned, Figures 5-6 show 5 of the 7 intersections and Table 3 (Existing LOS) reports 6 of the 7 study intersections.

Consider adding a section near the front of the report (e.g. Section 2 or 3) that lists all study intersections that will have metrics reported throughout the entire report. Adding them to Figure 1 for example may help with clarifying where all of the key study intersections are located.

Response #4: A new section, "Study Area," has been added to the TIA report to clarify study intersections and performance measures.

Comment #5: Page 17: For Table 4 (Collisions), Separate out and identifying each location as an intersection or a corridor. Consider using the same numbering for the intersections as what was used for the operational analysis and creating new numbering for the corridor locations. Consider adding totals for each column and row to add more clarity to the data.

Response #5: Crash summary tables have been reconfigured.

Comment #6: Page 18: Consider updating Tables 5 and 6 also with Ref # and intersection/corridor names for clarity and adding total columns/rows.

Response #6: Crash summary tables have been reconfigured.

Comment #7: Page 18: Consider expanding further on the text "Out of the 45 total collisions, one resulted in six non-incapacitating injuries, and six possible injuries". Should it say something like 6 of the 45 collisions resulted in non-incapacitating and 6 of the 45 resulted in possible injury?

Response #7: Text has been revised for clarity.

Comment #8: Page 20: For figure 8, consider adding numbering to intersections/corridors to tie back to tables easier.

Response #8: Intersection and street corridor numbering has been added to Figure 8.

Comment #9: Pages 16 & 35: Provide more details in the notes of Tables 3 and 9 related to delay and LOS for clarification - Signals, use signalized thresholds for overall intersection, AWSC/Roundabout - use stop control thresholds for overall intersection, TWSC use stop control thresholds for worst approach.

Response #9: Notes have been added to LOS tables.



Comment #10: [General comment]: Provide additional discussion on the Sunrise Ridge extension and what project or development will trigger the opening. Will the extension be completed as part of the Pinnacle at Liberty Bay development?

Response #10: The Sunrisde Ridge Avenue NE extension will be completed as part of the project's first phase. An explanatory statement has been added to the "Study Area" section of the report.

Comment #11: [General comment:] Adding the access points to the study area map or site plan would be helpful in understanding the traffic to and from the site. Consider adding labels for access points A, B, C/D, and E to the maps/figures.

Response #11: Site plan (Figure 2) has been updated to identify access locations.

Comment #12: [General comment:] The city guidelines state that intersections should be analyzed for intersections with over approximately 10 new trips added. Were additional intersections to the north or west of Hostmark Street/SR 305 considered for analysis (where >10 trips along those roadways are being generated per Figures 9 and 10).

Response #12: The TIA study area was approved by City staff via email on June 10, 2025. Minor scoping revisions provided by City staff at that time were incorporated to the TIA and are reflected in the report.



PLANS, SPECIFICATIONS AND ESTIMATE Review Comment Disposition Form

Project Title:	Pinnacle at Liberty Bay	Job Charge #:																																																																																																																																																																																																																																																													
Reviewer (name & office) Casey Chilton– Traffic Design		Responses By: Andrew L. Bratlien, PE, PTOE																																																																																																																																																																																																																																																													
Date of Review Comments: 7/29/25		Date of Disposition: 3/26/2026																																																																																																																																																																																																																																																													
Comment No.	Sht or Pg.	Review Comment	Status Code Designer's Response																																																																																																																																																																																																																																																												
1.	PDF p8	SR 305 speed limit at this location is 50 MPH. The roundabout at Johnson Rd NE and SR 305 includes pedestrian and bike facilities, but they do not continue along SR 305. Can you please mark "no" for these categories? An asterisk with a note about the RAB having facilities would be a great way to document this.	Table 1 has been updated to incorporate these comments.																																																																																																																																																																																																																																																												
2.	PDF p9	Future analysis assumes Sunrise Ridge Ave NE will be opened to through traffic, can you please add details on why this assumption was made? Did the city confirm if/when this will happen?	The Sunrise Ridge Ave NE extension will be completed as part of the project's first phase. An explanatory statement has been added to the "Study Area" section of the report.																																																																																																																																																																																																																																																												
3.	GEN	<p>Can you please speak to why the addition of the project traffic volumes will result in a decrease in delay at the following locations? If optimize was used, please reproduce without.</p> <p style="text-align: center;">Table 8: Forecast 2032 & 2037 Weekday Peak Hour Level of Service <small>Delay Given in Seconds per Vehicle</small></p> <table border="1" style="width: 100%; border-collapse: collapse; text-align: center;"> <thead> <tr> <th rowspan="2">Intersection</th> <th rowspan="2">Control</th> <th rowspan="2">Peak-Hour</th> <th rowspan="2">Crt. Apprch</th> <th colspan="2">Without Project</th> <th colspan="2">With Project</th> </tr> <tr> <th>LOS</th> <th>Delay</th> <th>LOS</th> <th>Delay</th> </tr> </thead> <tbody> <tr> <td colspan="8">Forecast 2032 Peak Hour Analysis</td> </tr> <tr> <td>SR 305 & Hostmark</td> <td>Signal</td> <td>AM</td> <td>Overall</td> <td>D</td> <td>36.5</td> <td>D</td> <td>37.2</td> </tr> <tr> <td></td> <td></td> <td>PM</td> <td></td> <td>D</td> <td>44.5</td> <td>D</td> <td>44.7</td> </tr> <tr> <td>SR 305 & Baywatch</td> <td>One-Way Stop</td> <td>AM</td> <td>SB</td> <td>C</td> <td>21.8</td> <td>C</td> <td>16.4</td> </tr> <tr> <td></td> <td></td> <td>PM</td> <td></td> <td>D</td> <td>25.8</td> <td>C</td> <td>24.7</td> </tr> <tr> <td>SR 305 & Johnson</td> <td>RAB</td> <td>AM</td> <td>Overall</td> <td>A</td> <td>7.4</td> <td>A</td> <td>7.7</td> </tr> <tr> <td></td> <td></td> <td>PM</td> <td></td> <td>A</td> <td>6.6</td> <td>A</td> <td>6.8</td> </tr> <tr> <td>Sunrise Ridge & Johnson</td> <td>RAB</td> <td>AM</td> <td>Overall</td> <td>A</td> <td>5.4</td> <td>A</td> <td>5.7</td> </tr> <tr> <td></td> <td></td> <td>PM</td> <td></td> <td>A</td> <td>6.0</td> <td>A</td> <td>6.5</td> </tr> <tr> <td>Sunrise Ridge & Crystallia</td> <td>One-Way Stop</td> <td>AM</td> <td>EB</td> <td>--</td> <td>--</td> <td>A</td> <td>8.8</td> </tr> <tr> <td></td> <td></td> <td>PM</td> <td></td> <td></td> <td></td> <td>A</td> <td>8.8</td> </tr> <tr> <td>Hostmark & Caldart</td> <td>AWSC</td> <td>AM</td> <td>Overall</td> <td>C</td> <td>22.6</td> <td>C</td> <td>24.2</td> </tr> <tr> <td></td> <td></td> <td>PM</td> <td></td> <td>B</td> <td>14.9</td> <td>C</td> <td>15.2</td> </tr> <tr> <td>Sunrise Ridge & Caldart</td> <td>TWSC</td> <td>AM</td> <td>NB</td> <td>A</td> <td>9.7</td> <td>A</td> <td>9.8</td> </tr> <tr> <td></td> <td></td> <td>PM</td> <td></td> <td>B</td> <td>10.0</td> <td>B</td> <td>10.1</td> </tr> <tr> <td colspan="8">Forecast 2037 Peak Hour Analysis</td> </tr> <tr> <td>SR 305 & Hostmark</td> <td>Signal</td> <td>AM</td> <td>Overall</td> <td>D</td> <td>37.0</td> <td>D</td> <td>37.6</td> </tr> <tr> <td></td> <td></td> <td>PM</td> <td></td> <td>D</td> <td>45.9</td> <td>D</td> <td>46.3</td> </tr> <tr> <td>SR 305 & Baywatch</td> <td>One-Way Stop</td> <td>AM</td> <td>SB</td> <td>C</td> <td>19.7</td> <td>C</td> <td>16.0</td> </tr> <tr> <td></td> <td></td> <td>PM</td> <td></td> <td>C</td> <td>23.5</td> <td>C</td> <td>23.7</td> </tr> <tr> <td>SR 305 & Johnson</td> <td>RAB</td> <td>AM</td> <td>Overall</td> <td>A</td> <td>7.5</td> <td>A</td> <td>7.7</td> </tr> <tr> <td></td> <td></td> <td>PM</td> <td></td> <td>A</td> <td>6.7</td> <td>A</td> <td>6.8</td> </tr> <tr> <td>Sunrise Ridge & Johnson</td> <td>RAB</td> <td>AM</td> <td>Overall</td> <td>A</td> <td>5.5</td> <td>A</td> <td>6.1</td> </tr> <tr> <td></td> <td></td> <td>PM</td> <td></td> <td>A</td> <td>5.9</td> <td>A</td> <td>6.4</td> </tr> <tr> <td>Sunrise Ridge & Crystallia</td> <td>One-Way Stop</td> <td>AM</td> <td>EB</td> <td>--</td> <td>--</td> <td>A</td> <td>8.9</td> </tr> <tr> <td></td> <td></td> <td>PM</td> <td></td> <td></td> <td></td> <td>A</td> <td>8.8</td> </tr> <tr> <td>Hostmark & Caldart</td> <td>AWSC</td> <td>AM</td> <td>Overall</td> <td>F</td> <td>61.9</td> <td>F</td> <td>63.3</td> </tr> <tr> <td></td> <td></td> <td>PM</td> <td></td> <td>D</td> <td>26.1</td> <td>D</td> <td>27.0</td> </tr> <tr> <td>Sunrise Ridge & Caldart</td> <td>TWSC</td> <td>AM</td> <td>NB</td> <td>A</td> <td>9.9</td> <td>B</td> <td>10.0</td> </tr> <tr> <td></td> <td></td> <td>PM</td> <td></td> <td>B</td> <td>10.4</td> <td>B</td> <td>10.5</td> </tr> </tbody> </table> <p><small>RAB: Roundabout</small></p> <p>SR 305 & Baywatch Court NE will operate acceptably at LOS D or better through 2037, with average delay of 26 seconds or less on the stop-controlled southbound</p>	Intersection	Control	Peak-Hour	Crt. Apprch	Without Project		With Project		LOS	Delay	LOS	Delay	Forecast 2032 Peak Hour Analysis								SR 305 & Hostmark	Signal	AM	Overall	D	36.5	D	37.2			PM		D	44.5	D	44.7	SR 305 & Baywatch	One-Way Stop	AM	SB	C	21.8	C	16.4			PM		D	25.8	C	24.7	SR 305 & Johnson	RAB	AM	Overall	A	7.4	A	7.7			PM		A	6.6	A	6.8	Sunrise Ridge & Johnson	RAB	AM	Overall	A	5.4	A	5.7			PM		A	6.0	A	6.5	Sunrise Ridge & Crystallia	One-Way Stop	AM	EB	--	--	A	8.8			PM				A	8.8	Hostmark & Caldart	AWSC	AM	Overall	C	22.6	C	24.2			PM		B	14.9	C	15.2	Sunrise Ridge & Caldart	TWSC	AM	NB	A	9.7	A	9.8			PM		B	10.0	B	10.1	Forecast 2037 Peak Hour Analysis								SR 305 & Hostmark	Signal	AM	Overall	D	37.0	D	37.6			PM		D	45.9	D	46.3	SR 305 & Baywatch	One-Way Stop	AM	SB	C	19.7	C	16.0			PM		C	23.5	C	23.7	SR 305 & Johnson	RAB	AM	Overall	A	7.5	A	7.7			PM		A	6.7	A	6.8	Sunrise Ridge & Johnson	RAB	AM	Overall	A	5.5	A	6.1			PM		A	5.9	A	6.4	Sunrise Ridge & Crystallia	One-Way Stop	AM	EB	--	--	A	8.9			PM				A	8.8	Hostmark & Caldart	AWSC	AM	Overall	F	61.9	F	63.3			PM		D	26.1	D	27.0	Sunrise Ridge & Caldart	TWSC	AM	NB	A	9.9	B	10.0			PM		B	10.4	B	10.5	Intersection operations forecasts have been updated to reflect revised trip generation, distribution and assignment forecasts. The intersections in question no longer indicate delay reductions with the addition of project trips.
Intersection	Control	Peak-Hour					Crt. Apprch	Without Project		With Project																																																																																																																																																																																																																																																					
			LOS	Delay	LOS	Delay																																																																																																																																																																																																																																																									
Forecast 2032 Peak Hour Analysis																																																																																																																																																																																																																																																															
SR 305 & Hostmark	Signal	AM	Overall	D	36.5	D	37.2																																																																																																																																																																																																																																																								
		PM		D	44.5	D	44.7																																																																																																																																																																																																																																																								
SR 305 & Baywatch	One-Way Stop	AM	SB	C	21.8	C	16.4																																																																																																																																																																																																																																																								
		PM		D	25.8	C	24.7																																																																																																																																																																																																																																																								
SR 305 & Johnson	RAB	AM	Overall	A	7.4	A	7.7																																																																																																																																																																																																																																																								
		PM		A	6.6	A	6.8																																																																																																																																																																																																																																																								
Sunrise Ridge & Johnson	RAB	AM	Overall	A	5.4	A	5.7																																																																																																																																																																																																																																																								
		PM		A	6.0	A	6.5																																																																																																																																																																																																																																																								
Sunrise Ridge & Crystallia	One-Way Stop	AM	EB	--	--	A	8.8																																																																																																																																																																																																																																																								
		PM				A	8.8																																																																																																																																																																																																																																																								
Hostmark & Caldart	AWSC	AM	Overall	C	22.6	C	24.2																																																																																																																																																																																																																																																								
		PM		B	14.9	C	15.2																																																																																																																																																																																																																																																								
Sunrise Ridge & Caldart	TWSC	AM	NB	A	9.7	A	9.8																																																																																																																																																																																																																																																								
		PM		B	10.0	B	10.1																																																																																																																																																																																																																																																								
Forecast 2037 Peak Hour Analysis																																																																																																																																																																																																																																																															
SR 305 & Hostmark	Signal	AM	Overall	D	37.0	D	37.6																																																																																																																																																																																																																																																								
		PM		D	45.9	D	46.3																																																																																																																																																																																																																																																								
SR 305 & Baywatch	One-Way Stop	AM	SB	C	19.7	C	16.0																																																																																																																																																																																																																																																								
		PM		C	23.5	C	23.7																																																																																																																																																																																																																																																								
SR 305 & Johnson	RAB	AM	Overall	A	7.5	A	7.7																																																																																																																																																																																																																																																								
		PM		A	6.7	A	6.8																																																																																																																																																																																																																																																								
Sunrise Ridge & Johnson	RAB	AM	Overall	A	5.5	A	6.1																																																																																																																																																																																																																																																								
		PM		A	5.9	A	6.4																																																																																																																																																																																																																																																								
Sunrise Ridge & Crystallia	One-Way Stop	AM	EB	--	--	A	8.9																																																																																																																																																																																																																																																								
		PM				A	8.8																																																																																																																																																																																																																																																								
Hostmark & Caldart	AWSC	AM	Overall	F	61.9	F	63.3																																																																																																																																																																																																																																																								
		PM		D	26.1	D	27.0																																																																																																																																																																																																																																																								
Sunrise Ridge & Caldart	TWSC	AM	NB	A	9.9	B	10.0																																																																																																																																																																																																																																																								
		PM		B	10.4	B	10.5																																																																																																																																																																																																																																																								
4.																																																																																																																																																																																																																																																															

Status Code Legend: **A = Incorporated** **B = Open/Under Review** **C = Evaluated/Not Incorporated** **D = Beyond Scope/Not Evaluated**
 All "B" and "C" responses require explanatory comments.

THE PINNACLE AT LIBERTY BAY TRAFFIC IMPACT ANALYSIS

CONTENTS

1. Introduction.....	5
2. Project Description.....	5
3. Study Area.....	8
4. Existing Conditions	8
5. Forecast Traffic Demand and Analysis	22
6. Conclusions & Mitigation	40

TABLES

1. Roadway Network	8
2. Bus Routes.....	9
3. 2025 Peak Hours	10
4. Existing Peak Hour Level of Service	17
5. Crash History by Year.....	18
6. Crash History by Type.....	19
7. Crash History by Severity.....	19
8. Project Trip Generation	22
9. Forecast 2032 & 2037 Weekday Peak Hour Level of Service	37



FIGURES

1. Vicinity Map.....	6
2. Site Plan	7
3. Existing AM Peak Hour Volumes	12
4. Existing PM Peak Hour Volumes.....	13
5. Existing AM Peak Hour Non-Motorist Volumes.....	14
6. Existing PM Peak Hour Non-Motorist Volumes	15
7. Safe Walking Route to Schools.....	16
8. Collision History Map.....	21
9. AM Peak Hour Trip Distribution & Assignment.....	24
10. PM Peak Hour Trip Distribution & Assignment.....	25
11. AM Peak Hour Pipeline Volumes.....	26
12. PM Peak Hour Pipeline Volumes	27
13. Forecast 2032 AM Peak Hour Volumes Without Project.....	28
14. Forecast 2032 PM Peak Hour Volumes Without Project	29
15. Forecast 2032 AM Peak Hour Volumes With Project.....	30
16. Forecast 2032 PM Peak Hour Volumes With Project	31
17. Forecast 2037 AM Peak Hour Volumes Without Project.....	32
18. Forecast 2037 PM Peak Hour Volumes Without Project	33
19. Forecast 2037 AM Peak Hour Volumes With Project.....	34
20. Forecast 2037 PM Peak Hour Volumes With Project.....	35
21. Construction Route	39



THE PINNACLE AT LIBERTY BAY

TRAFFIC IMPACT ANALYSIS

1. INTRODUCTION

Heath & Associates has been engaged to prepare a Traffic Impact Analysis (TIA) to assess the impacts of a proposed residential development within Poulsbo city limits. The tasks include reviewing existing traffic conditions in the site vicinity and comparing them to future buildout conditions, both with and without the proposed development. As a final step, conclusions, and if necessary, mitigation measures, will be identified. The TIA requirements were established during the scoping process with City staff. This TIA has been updated based on the March 2026 site plan, including a revised layout consisting of 138 dwelling units.

2. PROJECT DESCRIPTION

- **Proposal**
 - The Pinnacle at Liberty Bay is a proposed residential development consisting of 138 single-family homes located within Poulsbo.

- **Location**
 - The subject site is bordered to the east by Sunset Ridge Avenue NE and single-family residential development, to the west by single-family residential development, and to the south by SR 305 and undeveloped property.
 - The site comprises 40.98 acres on four undeveloped tax parcels, 232601-4-001-2009, -3-003-2008, -3-018-2001, and -3-005-2006.

- **Site Access**
 - Access to the site will be provided at four locations:
 1. Access A: Sunrise Ridge Avenue via extension of Crystallia Court
 2. Access B/C: Both sides of Sunrise Ridge Avenue 220 feet south of Crystallia Court
 3. Access D: Sunrise Ridge Avenue 380 feet south of Crystallia Court
 - Direct property access will be provided via a network of internal circulating roadways.

A vicinity map is provided in **Figure 1** with the subject site highlighted in blue. A conceptual site plan including access locations is presented in **Figure 2**.



Figure 1: Vicinity Map



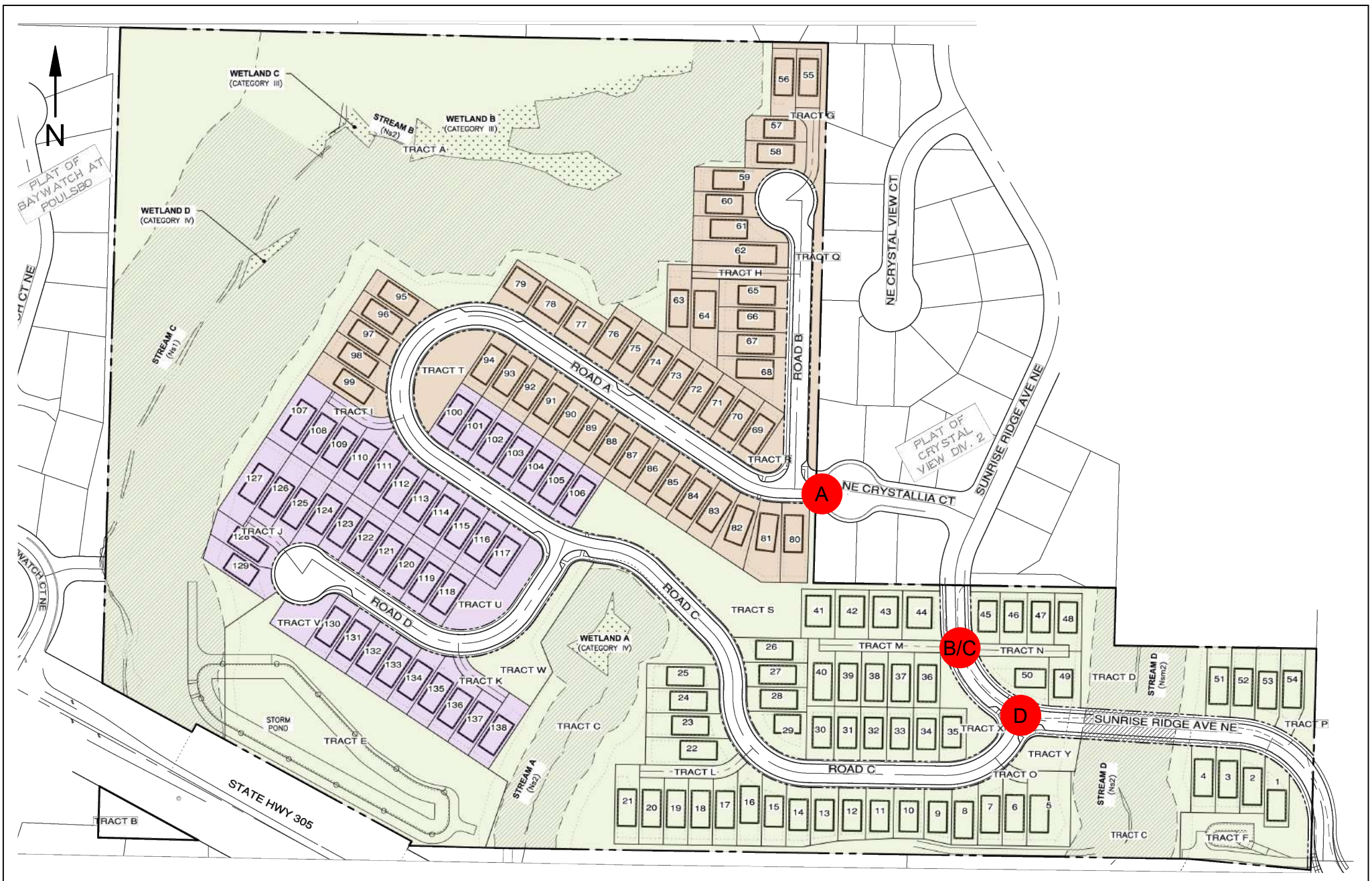

3. STUDY AREA

Study intersections were identified through scoping process and approved by City of Poulsbo staff. A total of seven study intersections were included in this analysis:

1. SR 305 & NE Hostmark Street
2. SR 305 & Baywatch Court NE
3. SR 305 & Johnson Road NE
4. NE Hostmark Street & Caldart Avenue NE
5. Johnson Road NE & Sunrise Ridge Avenue NE
6. Caldart Avenue NE & Sunrise Ridge Avenue NE
7. Sunrise Ridge Avenue NE & Crystallia Court

At the time of this analysis, Sunrise Ridge Avenue NE was gated to the northwest of Johnson Road NE. Therefore, the intersection of Sunrise Ridge Avenue NE & Crystallia Court (#7) currently operates with very low traffic volumes and was not included in this study’s existing conditions analysis.

The Sunrise Ridge Avenue NE connection to Johnson Road NE will be completed as part of The Pinnacle at Liberty Bay Phase 1; therefore the future conditions analysis considered all seven study intersections.

4. EXISTING CONDITIONS

4.1 Existing Street System

Characteristics of key roadways serving the subject site are provided in **Table 1**.

Table 1: Roadway Network

Functional Classification	Roadway	Speed Limit (mph)	Lanes	Sidewalk	Bike Facilities
Principal Arterial	SR 305	50	2-5	No*	No*
Minor Arterial	Johnson Rd NE	25	2	Yes	No
Neighborhood Collector	NE Hostmark St	15-25	2-3	Yes	Yes
	Caldart Ave NE	20-25	2	Yes	No
Local	Sunrise Ridge Ave NE	25	2	Yes	No
	Baywatch Ct NE	25	2	Yes	No

*SR 305 includes sidewalk and bike facilities only at the roundabout at SR 305 & Johnson Rd NE



4.2 Transit Service

A review of the Kitsap County Transit website indicates that transit is provided within one mile walking distance to/from the site. Route 344 – Poulsbo Central is provided at the intersection of Hostmark Street & Caldart Avenue approximately 3,500 feet north of the site. Route 333 – Silverdale/Bainbridge and Route 390 – Poulsbo/Bainbridge include stops at the intersection of SR 305 & Johnson Road, approximately 3,500 feet south of the project site. Each nearby route is identified in **Table 2** below. For more detailed information, refer to the Kitsap Transit website.

Table 2: Bus Routes

Route	Description	Weekday Service	Saturday	Sunday	Nearest Stop
333	Silverdale TC to Bainbridge Ferry	4:22 AM – 8:55 PM ¹	--	--	SR 305 & Johnson
344	North Viking TC to 10th & Forest Rock	8:30 AM – 7:20 PM	10:30 AM – 6:20 PM	--	Caldart & Hostmark
390	North Viking TC to Bainbridge Ferry	4:00 AM – 9:24 PM	8:08 AM – 7:37 PM	8:10 AM – 5:00 PM	SR 305 & Johnson

4.3 Roadway Improvements

The City of Poulsbo’s (2026-2031) Transportation Improvement Program (TIP) and Washington State Department of Transportation (WSDOT) 2025-2028 Statewide Transportation Improvement Program (STIP) were reviewed to identify planned transportation improvement projects in the site vicinity. The Poulsbo TIP identifies one such improvement, described below.

Noll Road Corridor Improvements (Priority #2): The phased corridor improvement project will connect SR 305 to NE Lincoln Rd via Noll Rd, Langaunet Ln & Maranatha Ln, providing roadway, illumination, sidewalk, and shared use path improvements. The project’s initial phase, including realignment of Noll Road, a new roundabout at the Noll Road/Johnson Road & Sunrise Ridge Avenue intersection, and a new roundabout with nonmotorized facilities at the Johnson Road NE/SR 305 intersection, has been completed. Future phases will provide a roundabout at Noll Road & Mesford Road, an extension of Langaunet Lane, and complete street improvements along the corridor from Noll Road/Storhoff Road to Lincoln Road.

¹ Route does not run midday from 7:35 AM to 3:45 PM.



At the time of this analysis, Sunrise Ridge Avenue NE is closed between Noll Road/Johnson Road NE and NE Crystallia Court. The future conditions analyses described in this report assumed that Sunrise Ridge Avenue NE will be opened to traffic by 2032, creating a new north-south local street connection between Noll Road/Johnson Road NE and Caldart Avenue to the north. The traffic volume impacts of the Sunrise Ridge Avenue connection are described later in this report.

4.4 Existing Peak Hour Volumes and Travel Patterns

Field data for this study was collected from 7-9 AM and from 4-6 PM on non-holiday school weekdays in May 2025 at the following intersections:

1. SR 305 & NE Hostmark Street
2. SR 305 & Baywatch Court NE
3. SR 305 & Johnson Road NE
4. NE Hostmark Street & Caldart Avenue NE
5. Johnson Road NE & Sunrise Ridge Avenue NE

Traffic volumes at the intersections of Sunrise Ridge Avenue NE & Caldart Avenue and Sunrise Ridge Avenue NE & Crystallia Court were estimated based on traffic counts at nearby intersections and existing development patterns. Trips generated by existing development in the vicinity of the intersections were estimated using methodology and data published in the Institute of Transportation Engineers *Trip Generation Manual 11th Edition*.

Traffic counts at each intersection were reviewed to identify the one-hour peak period during each count, which was then applied to the intersection capacity analysis. The AM and PM peak hours of traffic volumes at each intersection are shown in **Table 3**. **Figures 3 and 4** illustrate existing AM and PM peak hour volumes at counted intersections. Full turning movement count sheets are available in the appendix.

Table 3: 2025 Peak Hours

Study Intersection	AM Peak Hour	PM Peak Hour
SR 305 & Hostmark	7:00 - 8:00 AM	4:00 - 5:00 PM
SR 305 & Baywatch	8:00 - 9:00 AM	4:30 - 5:30 PM
SR 305 & Johnson	7:00 - 8:00 AM	4:15 - 5:15 PM
Hostmark & Caldart	7:15 - 8:15 AM	4:45 - 5:45 PM
Johnson Rd & Sunrise Ridge	7:15 - 8:15 AM	4:00 - 5:00 PM



Traffic volume data indicated that the morning peak hour generally coincides with the school drop-off period and the morning commuter “rush hour.” These concurrent phenomena are reflected in the AM peak hour analyses described in this report. The afternoon school peak period is generally brief and is offset from the overall afternoon peak hour of travel demand, which occurs later and is characterized by commuters returning home from work as well as recreational and shopping trips. The PM peak hour analysis described in this report focused on the overall systemwide peak to provide a worst-case analysis.

4.5 Nonmotorized Conditions

Nonmotorized traffic was included in the AM and PM peak hour counts. Refer to **Figures 5 and 6** for AM and PM peak hour nonmotorized peak hour activity at each study intersection.

Nonmotorized infrastructure in the project vicinity includes sidewalks along both sides of Sunrise Ridge Avenue NE, Caldart Avenue NE, NE Hostmark Street, and Johnson Road NE. Sidewalks along Johnson Road NE to the south of the project provide a nonmotorized connection to transit stops on SR 305. The planned Noll Road corridor improvements will provide sidewalk and shared-use path facilities to the northeast of the project.

The internal circulating street network will include sidewalks and marked pedestrian crosswalks in the project site.

School-aged residents of the project would likely attend Poulsbo Elementary School and Poulsbo Middle School, both located approximately 1.0-miles walking distance to the north of the site. Continuous sidewalk segments, marked crosswalks, and reduced school speed zone signs are provided between the site and schools facilitating student transport. Refer to **Figure 7** for the pedestrian routes to and from each school.



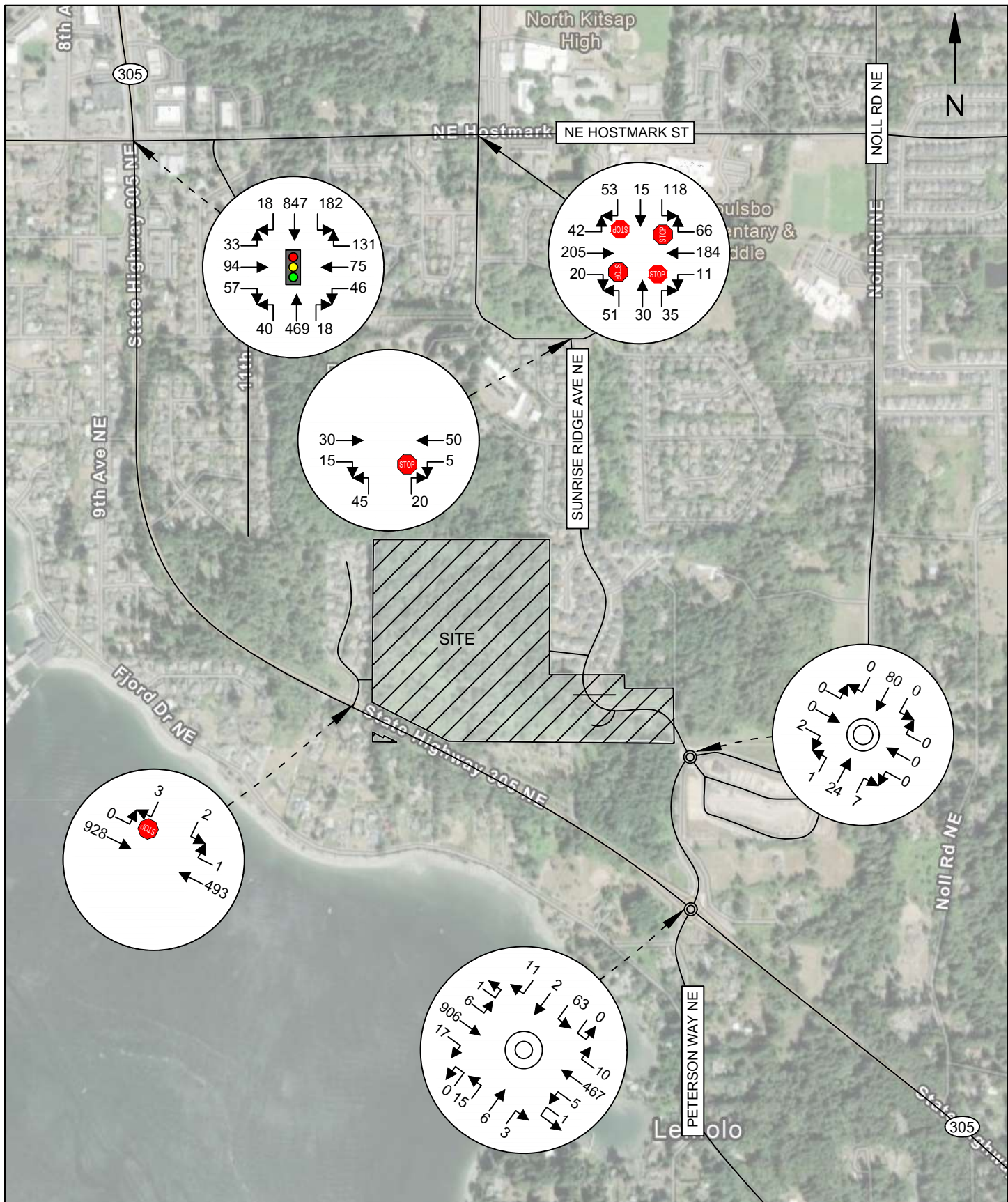

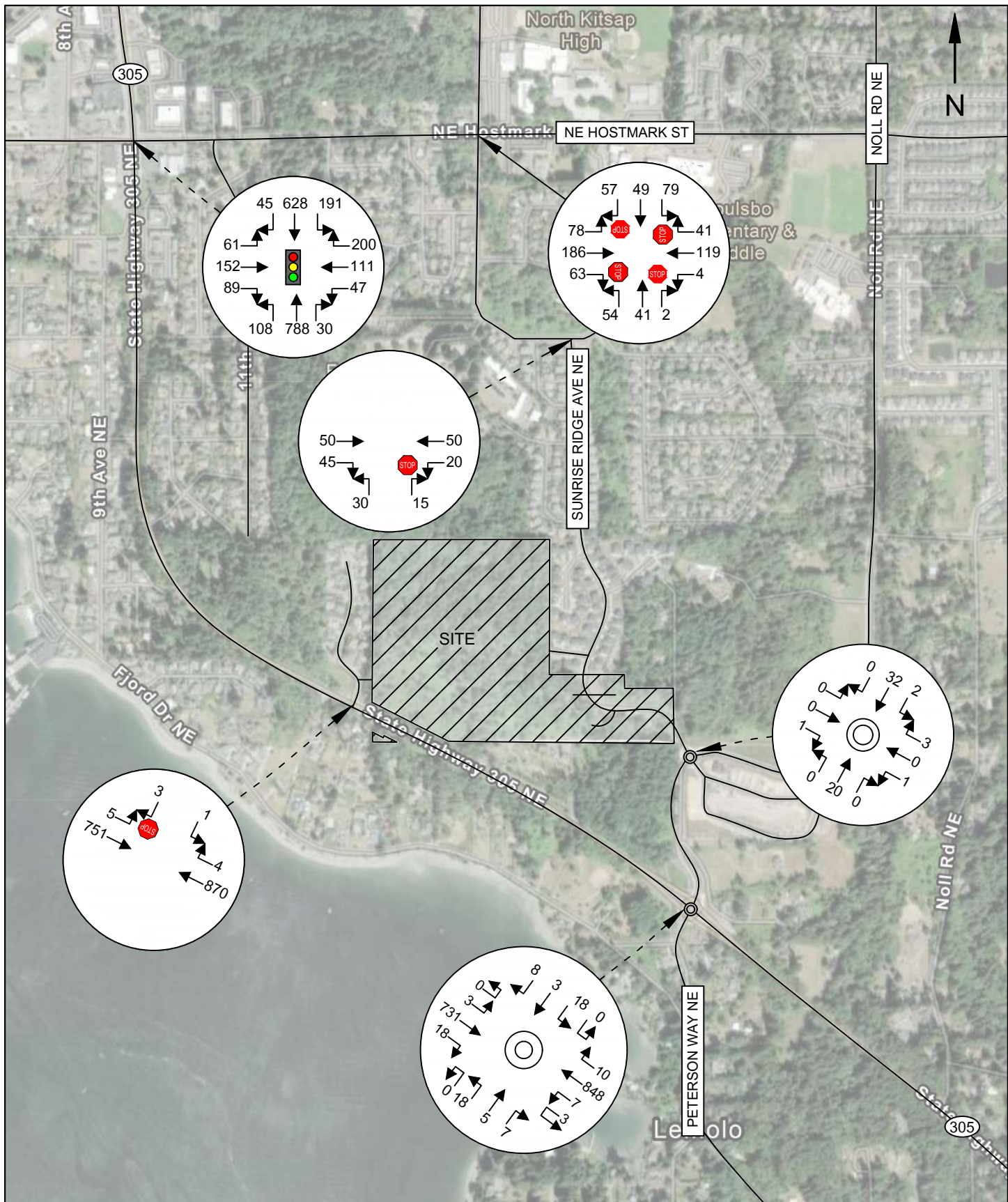

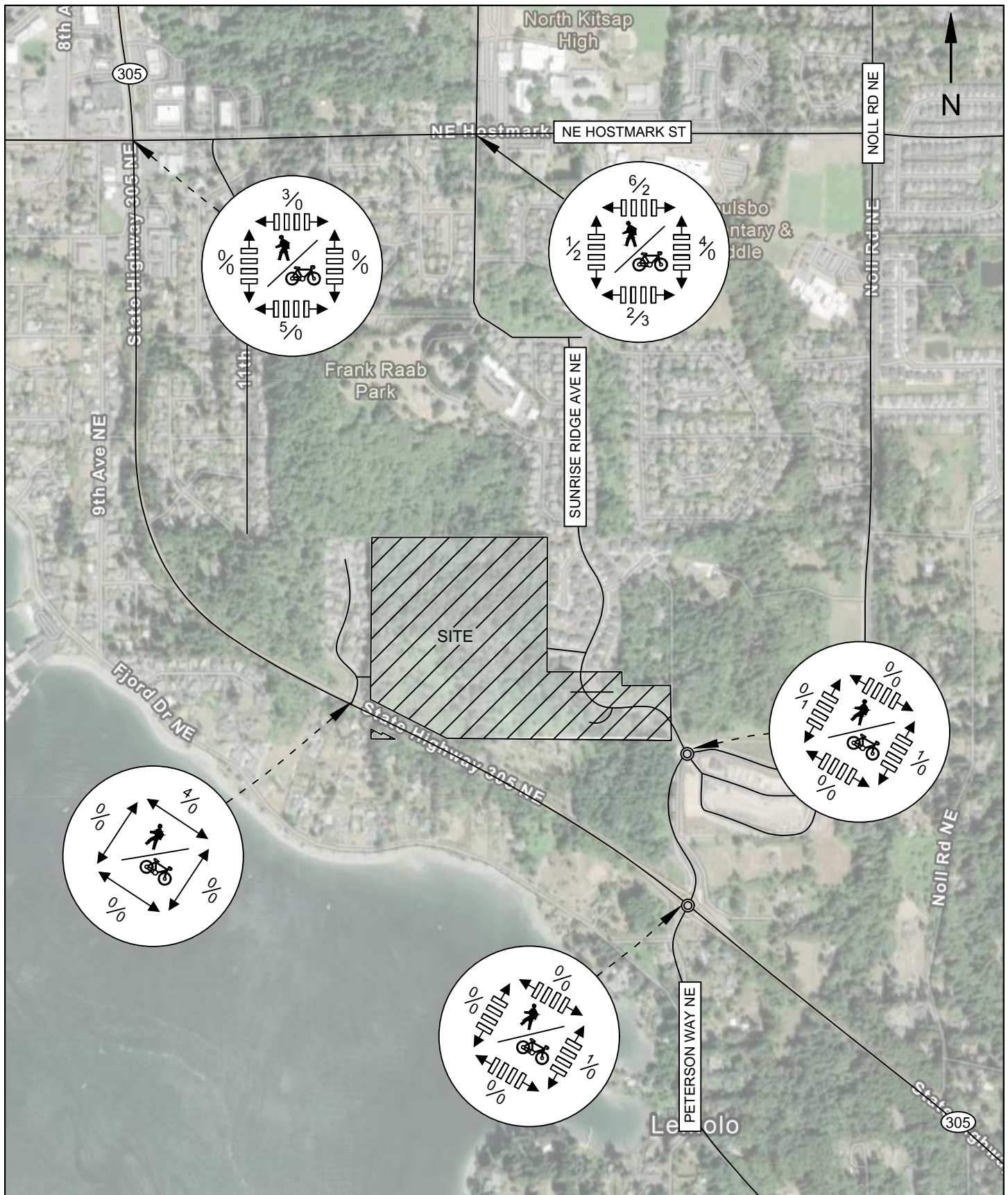

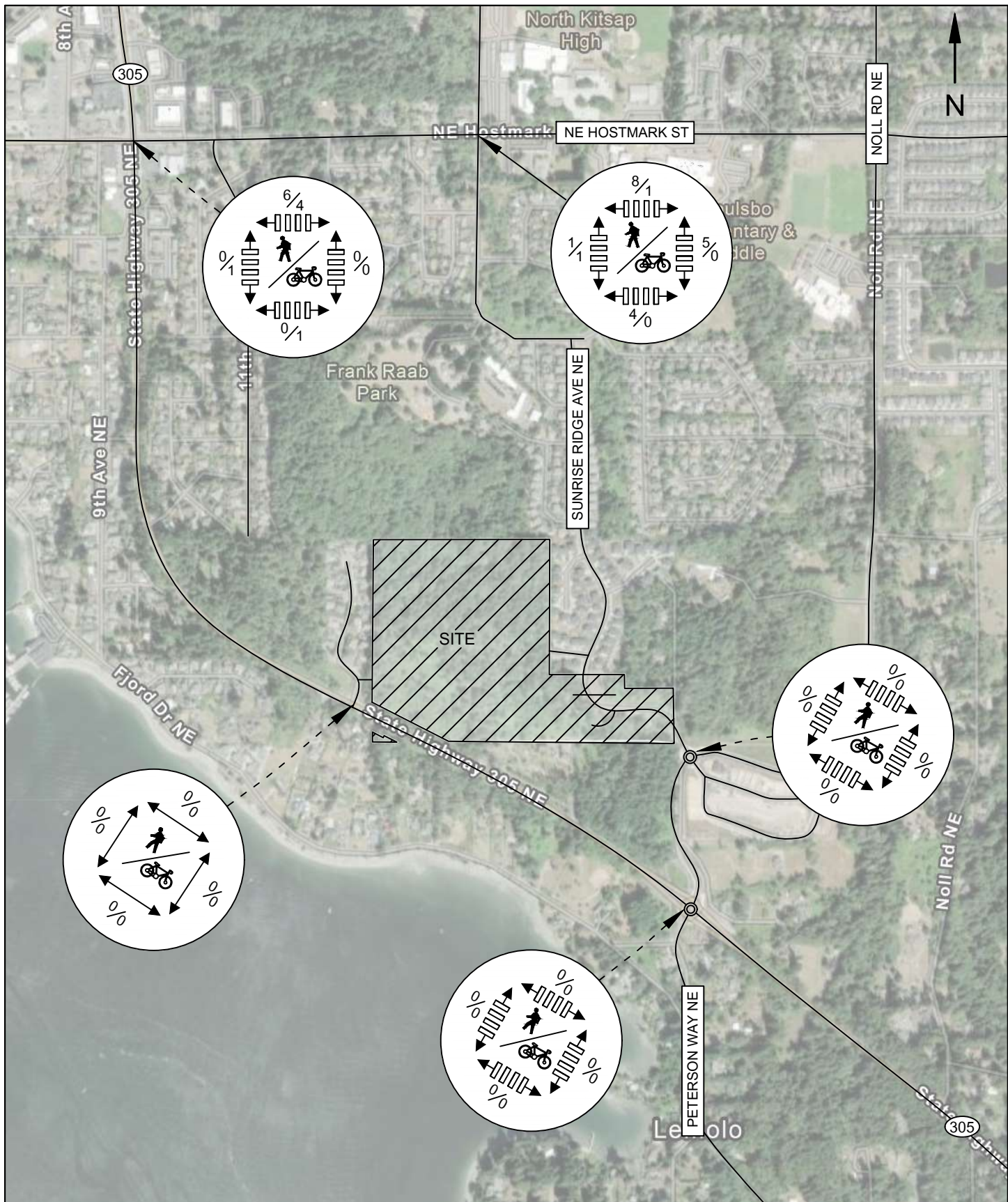

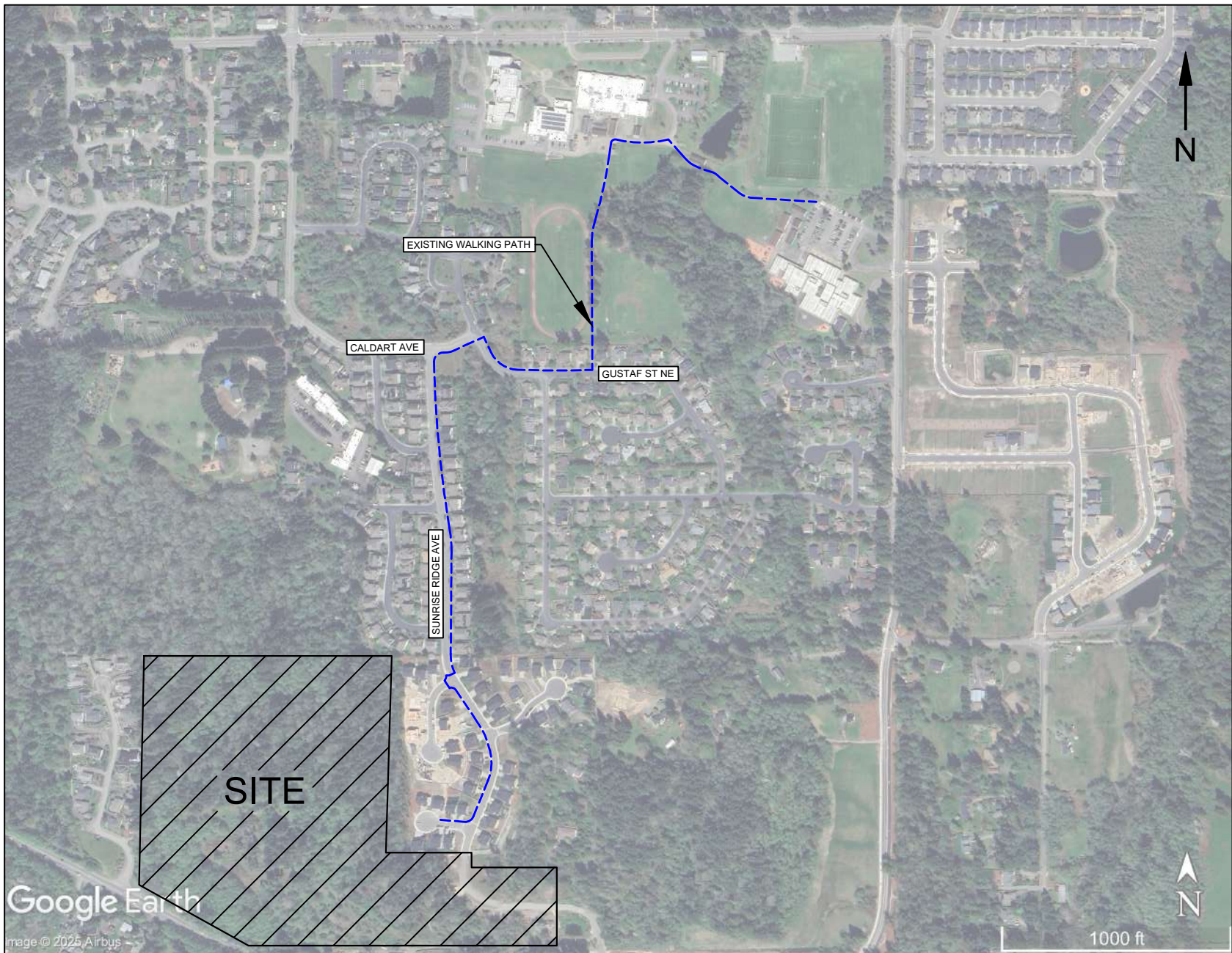

4.6 Existing Level of Service

Level of Service (LOS) is a measure of congestion for transportation facilities which uses a range² from LOS A to LOS F, where LOS A indicates free-flow conditions with low delay and LOS F indicates congested conditions with high delay. For minor-approach stop-controlled intersections, LOS is determined by the highest-delay approach. For all other intersections, LOS is defined by the overall intersection delay.

Signalized and stop-controlled intersection operations were analyzed in Synchro 12 software using *Highway Capacity Manual 7th Edition* methodologies. Roundabout operations were analyzed in Sidra Intersection 10 software using WSDOT Sidra analysis guidance. Results of the existing LOS analysis are summarized in **Table 4**.

The City of Poulsbo has adopted a minimum LOS E standard for City intersections. Minimum LOS standards for State-owned facilities are set by WSDOT. The WSDOT minimum LOS standard for SR 305 is LOS D.

Table 4: Existing Peak Hour Level of Service

Delays given in seconds per vehicle

Intersection	Control	Peak Hour	Critical Approach	LOS*	Delay
SR 305 & Hostmark St	Signal	AM	Overall	D	35.9
		PM		D	44.0
SR 305 & Baywatch Ct	One-Way Stop	AM	SB	C	20.5
		PM		C	23.8
SR 305 & Johnson Rd	RAB	AM	Overall	A	7.1
		PM		A	6.4
Hostmark & Caldart	AWSC	AM	Overall	C	15.1
		PM		B	12.0
Johnson Rd & Sunrise Ridge	RAB	AM	Overall	A	5.1
		PM		A	5.1
Caldart Ave & Sunrise Ridge	TWSC	AM	NB	A	9.4
		PM		A	9.7

*Signalized intersection LOS is based on overall intersection delay;
 Roundabout and AWSC LOS is based on overall intersection delay and stop-controlled delay thresholds;
 Minor-approach stop control LOS is based on worst-approach delay and stop-controlled delay thresholds

² Signalized Intersections - Level of Service

Level of Service	Control Delay (sec/veh)
A	<10
B	≥10 and <20
C	≥20 and <35
D	≥35 and <55
E	≥55 and <80
F	≥80

Stop Controlled Intersections - Level of Service

Level of Service	Control Delay (sec/veh)
A	<10
B	≥10 and <15
C	≥15 and <25
D	≥25 and <35
E	≥35 and <50
F	≥50

Source: *Highway Capacity Manual, 7th Edition*



All intersections currently operate at LOS D or better, satisfying their respective minimum LOS standards during the AM and PM peak hours.

4.7 Collision History

Crash history data in the project vicinity for the five-year period from 2020 through 2024 was obtained from WSDOT and is summarized below. **Table 5** describes crash history by year.

Table 5: Crash History by Year

(Ref #) Intersection/Segment	2020	2021	2022	2023	2024	Total	Avg/Yr
<i>Study Intersections</i>							
(I1) SR 305 & Hostmark St	2	3	2	1	4	12	2.4
(I2) SR 305 & Baywatch Ct	0	0	1	0	1	2	0.4
(I3) SR 305 & Johnson Rd	3	0	3	3	4	13	2.6
(I4) Hostmark St & Caldart Ave	2	1	0	2	0	5	1.0
(I5) Johnson Rd & Sunrise Ridge	0	0	0	0	0	0	0.0
(I6) Caldart Ave & Sunrise Ridge	0	0	0	0	0	0	0.0
(I7) Sunrise Ridge & Crystallia Ct	0	0	0	0	0	0	0.0
<i>Study Street Segments</i>							
(S1) SR 305 s/o Hostmark St	0	2	3	0	2	7	1.4
(S2) SR 305 s/o Baywatch Ct	0	2	0	0	0	2	0.4
(S3) SR 305 s/o Johnson Rd	1	0	0	1	0	2	0.4
(S4) Caldart Ave n/o Hostmark	0	0	0	1	1	2	0.4
Total (All Intersections & Segments)	8	8	9	8	12	45	9.0

A total of 45 crashes were recorded in the study area during the five-year study period, including 12 resulting in injury. No serious injury or fatal crashes were reported. Crashes are summarized by type in **Table 6** and by severity in **Table 7**.



Table 6: Crash History by Type

Crash Type	Number of Crashes (2020-2024)										
	Intersections							Street Segments			
	I1	I2	I3	I4	I5	I6	I7	S1	S2	S3	S4
Rear-end	5	0	8	3	0	0	0	3	0	1	0
Enter at angle	2	0	1	1	0	0	0	1	0	0	0
Opposite direction	3	0	1	0	0	0	0	2	0	0	0
Same direction	1	0	0	0	0	0	0	0	0	0	0
Pedestrian-Involved	1	0	0	1	0	0	0	0	0	0	0
Sideswipe	0	0	2	0	0	0	0	1	0	1	0
Struck fixed object	0	2	0	0	0	0	0	0	2	0	2
Vehicle overturned	0	0	1	0	0	0	0	0	0	0	0

Table 7: Crash History by Severity

(Ref #) Intersection/Segment	Fatal (K)	Serious Injury (A)	Minor Inj. (B)	Possible Inj. (C)	PDO
(I1) SR 305 & Hostmark St	0	0	1	1	10
(I2) SR 305 & Baywatch Ct	0	0	0	0	2
(I3) SR 305 & Johnson Rd	0	0	2	2	9
(I4) Hostmark St & Caldart Ave	0	0	1	2	2
(I5) Johnson Rd & Sunrise Ridge	0	0	0	0	0
(I6) Caldart Ave & Sunrise Ridge	0	0	0	0	0
(I7) Sunrise Ridge & Crystallia Ct	0	0	0	0	0
(S1) SR 305 s/o Hostmark St	0	0	1	1	5
(S2) SR 305 s/o Baywatch Ct	0	0	0	0	2
(S3) SR 305 s/o Johnson Rd	0	0	1	0	1
(S4) Caldart Ave n/o Hostmark	0	0	0	0	2

Six of the 45 total crashes resulted in minor injuries, and six crashes resulted in possible injuries. Two pedestrian-involved crashes were reported and are summarized below. A crash history map is provided in **Figure 8**.

Vehicle Going Straight Hits Pedestrian (August 2023):

This crash occurred in August 2023 at 2:30 PM when a vehicle traveling eastbound on Hostmark Street struck a pedestrian between Caldart Avenue and Noll Road. The crash occurred in daylight with dry roadway conditions. Pedestrian failure to grant



right-of-way to vehicle was cited as a contributing factor. The collision resulted in a suspected minor injury.

Vehicle Going Straight Hits Pedestrian (October 2024):

This crash occurred at the intersection of SR 305 & Hostmark Street in October 2024 at 5:10 PM vehicle traveling southbound on SR 305 struck a pedestrian. The crash occurred during daylight with a dry roadway surface. Pedestrian failure to grant right-of-way to vehicle was cited as a contributing factor. The crash resulted in a suspected minor injury.



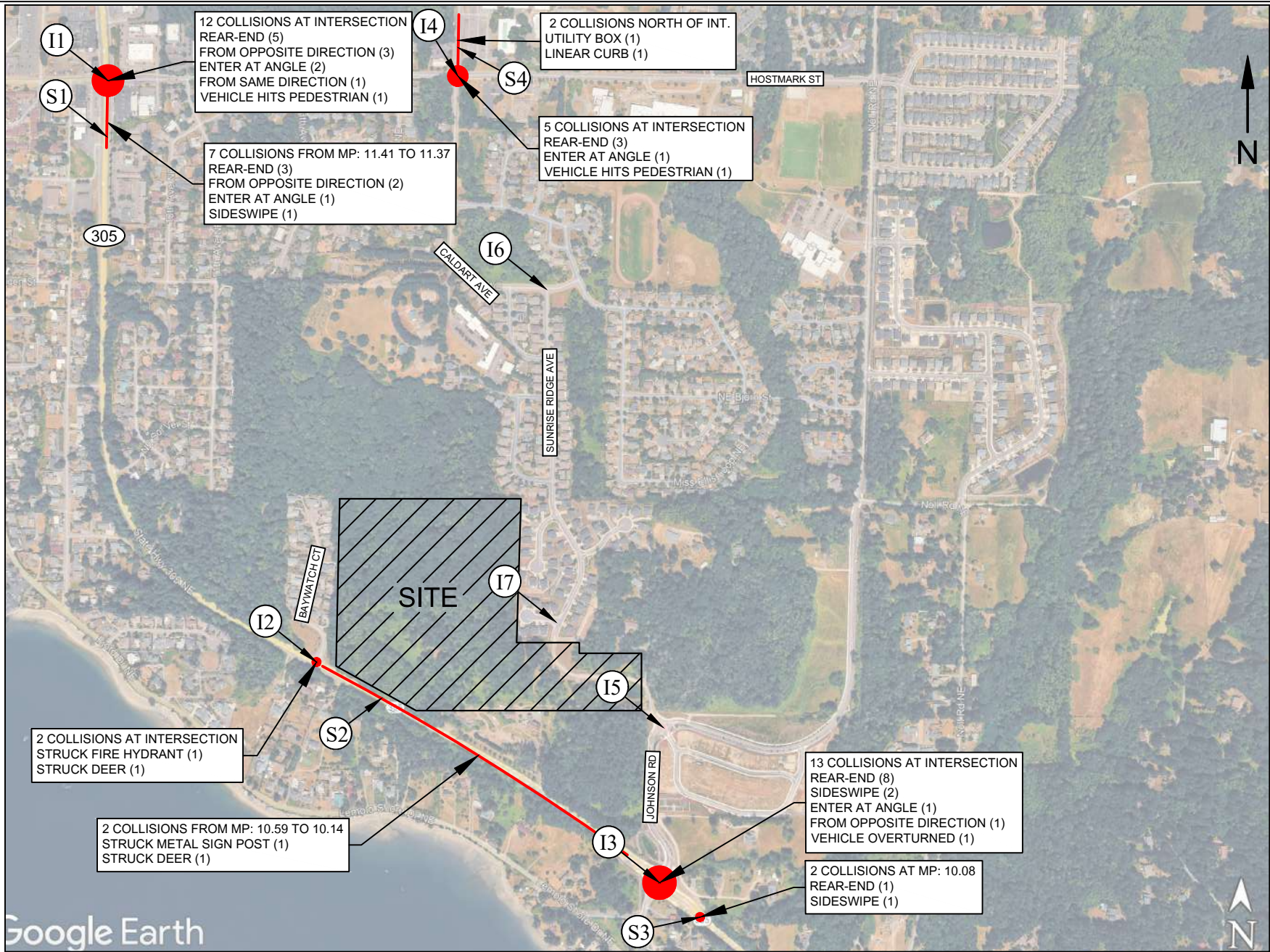

5. FORECAST TRAFFIC DEMAND & ANALYSIS

5.1 Project Trip Generation

Trip generation is used to assess the impact a project will have on the surrounding street system by estimating the number of new trips that will enter and exit the site during specific time periods, such as peak hours (AM or PM) or over the course of a day. The expected vehicle trip generation for the proposed project was calculated using data from the Institute of Transportation Engineers (ITE) *Trip Generation Manual, 12th Edition*. For this analysis, Land Use Code (LUC) 210 - Single-Family Detached Housing was selected, with dwelling units used as the input variable and ITE average rates applied to determine the number of trip ends.

A summary of the average weekday daily trips (AWDT), AM peak hour trips, and PM peak hour trips are shown below in **Table 8**.

Table 8: Project Trip Generation

Land Use	Units	AWDT	AM Peak-Hour Trips			PM Peak-Hour Trips		
			In	Out	Total	In	Out	Total
LUC 210 - Single-Family Housing	138	1,254	26	71	97	80	48	128

Based on ITE data, the project is estimated to generate 1,254 daily weekday trips, 97 AM peak hour trips (26 inbound / 71 outbound), and 128 PM peak hour trips (80 inbound / 48 outbound).

5.2 Project Distribution & Assignment

Trip distribution is the process by which project-generated trips are paired with origins and destinations in the vicinity of the project site. The project trip distribution forecast was calculated based on recent traffic counts, existing and anticipated development in the project vicinity, and with consideration for other recent residential projects in the vicinity.

Project trip distribution and assignment forecasts, shown in **Figures 9** and **10**, assumed completion of the Sunrise Ridge Avenue NE corridor which will provide a connection between Noll Road/Johnson Road and Caldart Avenue.



5.3 Future Peak Hour Volumes

Future traffic volumes were forecast for seven-year (2032) and 12-year (2037) analysis periods. Background (non-Project) traffic volumes were forecast as the sum of two components:

1. **Pipeline growth** reflects the impacts of specific projects which have been permitted in the project vicinity. Pipeline projects were identified by City of Poulsbo staff and included:
 - a. Aktiv Mixed-Use, a 44-unit multifamily residential development located at the corner of NE Harrison Street and 9th Avenue NE.
 - b. Audrey Estates, a 60-unit single-family residential development located to the east of the project site. Audrey Estates is bordered by Noll Road to the east and south, with access on Sunrise Ridge Avenue.
 - c. Sandstone Ridge Plat, an 87-unit single-family residential development located at the corner of Noll Road NE & Langaunet Lane NE.
2. **Background growth** reflects the impacts of other local and regional growth which is anticipated to impact the study area. Background growth was calculated by applying growth rates:
 - a. For SR 305, a growth rate of 0.5 percent per year was applied. This is consistent with SR 305 forecasts identified in the travel demand model, which constitutes the basis of the Transportation Element of the Poulsbo Comprehensive Plan
 - b. For all other streets, a growth rate of 2.0 percent per year was applied. This represents a more aggressive growth forecast than the 1.2 percent per year growth rate identified in the Poulsbo travel demand model. However, this growth rate was selected to allow the analysis to reflect a “worst case” forecast given recent growth in the project vicinity.

All future year analyses assumed Sunrise Ridge Avenue NE will be opened to traffic by 2032, creating a new north-south local street connection between Noll Road/Johnson Road NE and Caldart Avenue to the north. The new connection will provide a low-speed, circuitous alternative to the more direct Noll Road corridor, and will be designed to discourage cut-through demand. However, some redistribution and cut-through demand may occur. This analysis assumed that the new connection will capture 20 percent of existing AM and PM peak hour demand on the Noll Road corridor to the east. This results in a Sunrise Ridge Avenue traffic volume forecast which is generally consistent with the City of Poulsbo travel demand model forecast.

AM and PM peak hour pipeline volumes are shown in **Figures 11 and 12**. Future 2032 and 2037 AM and PM peak hour traffic volumes forecasts are shown graphically in **Figures 13 through 20**.



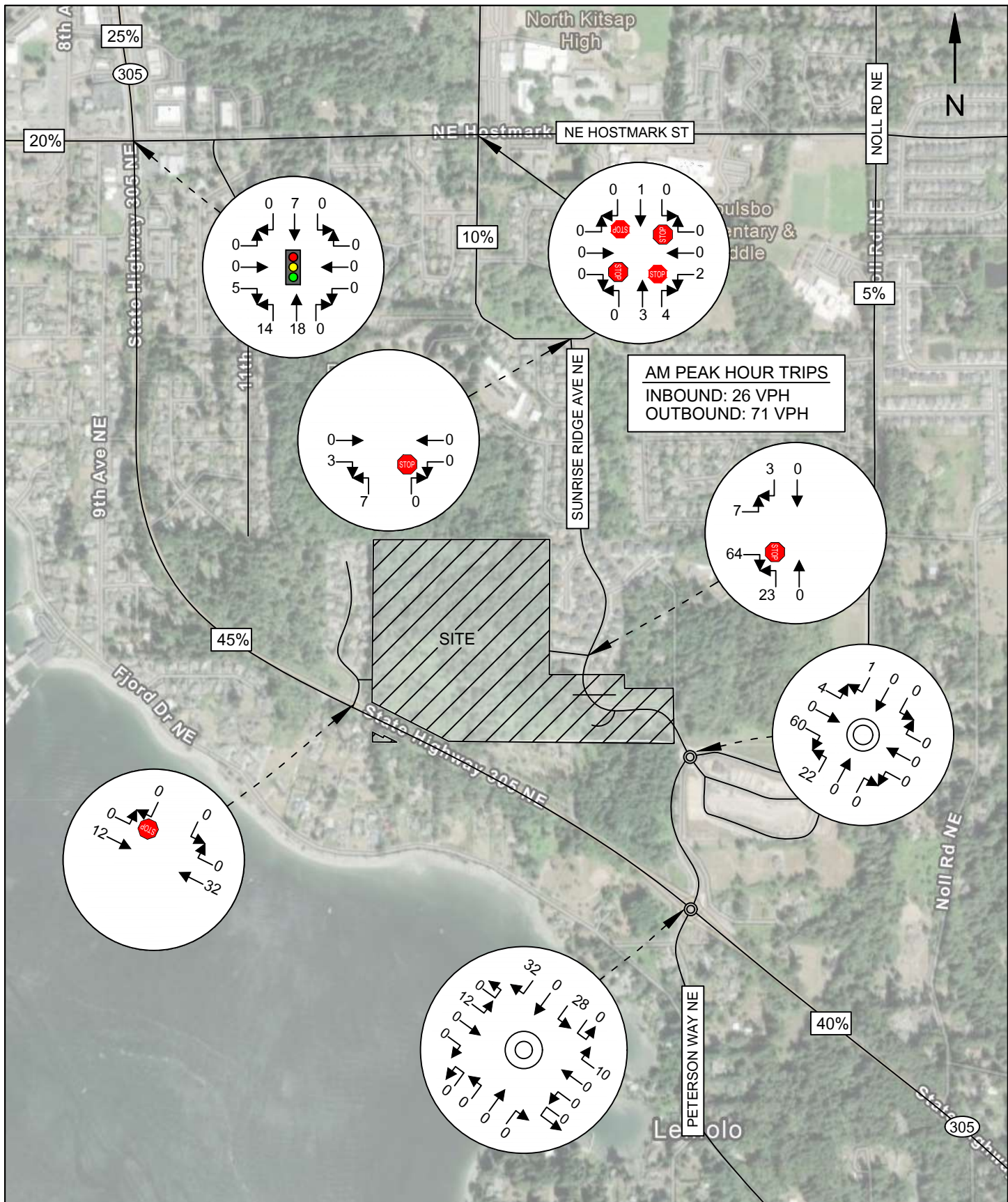

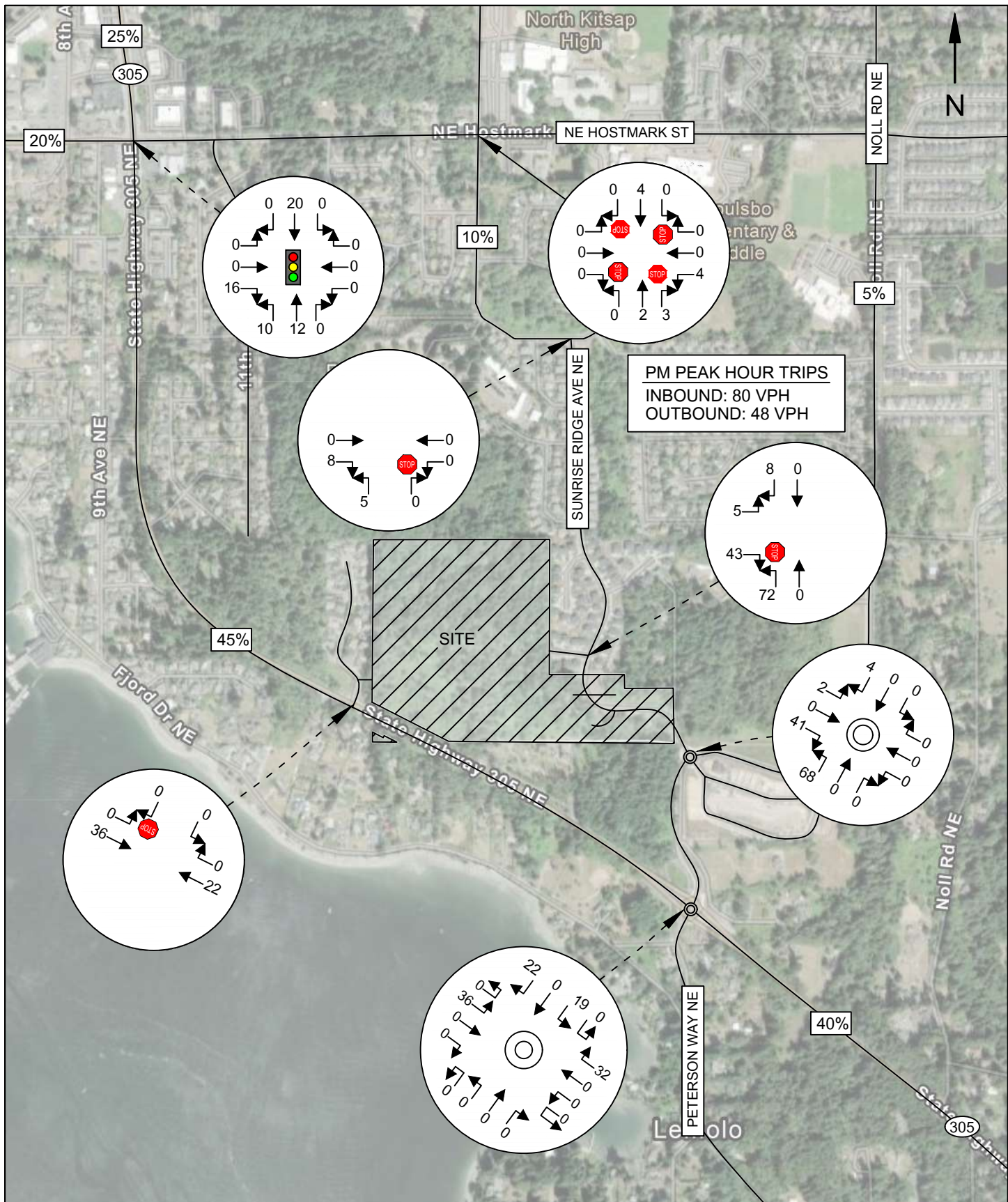

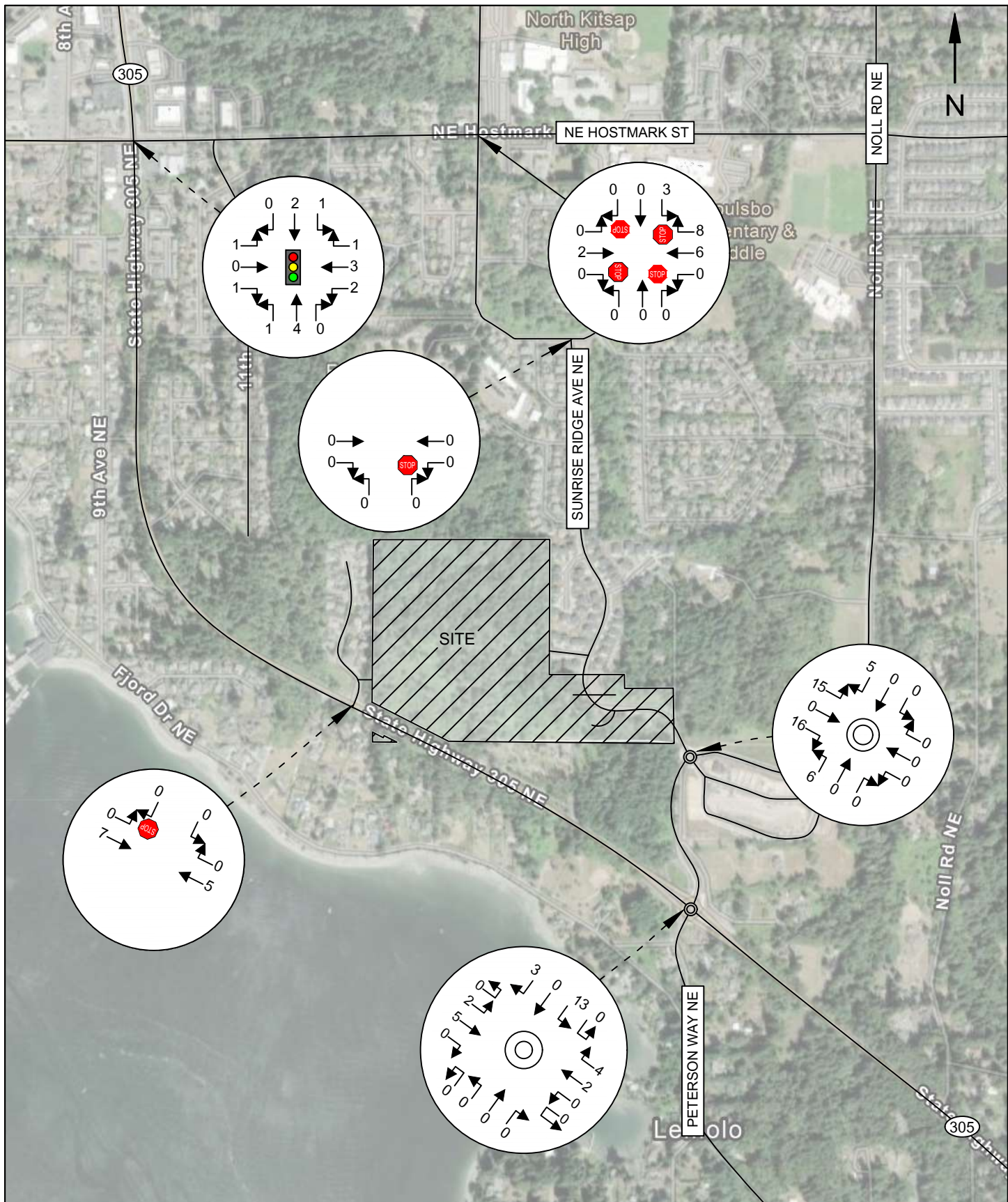

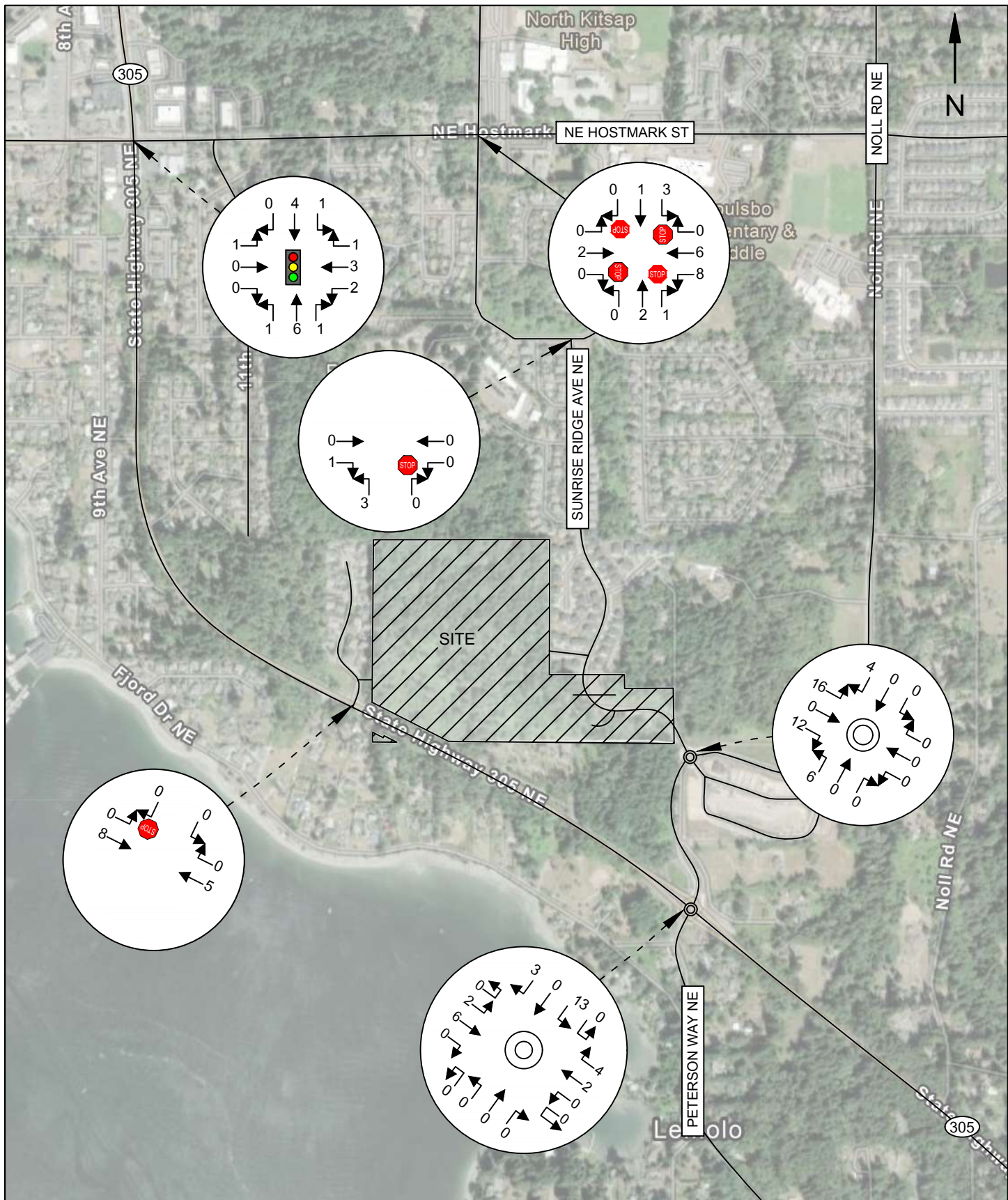

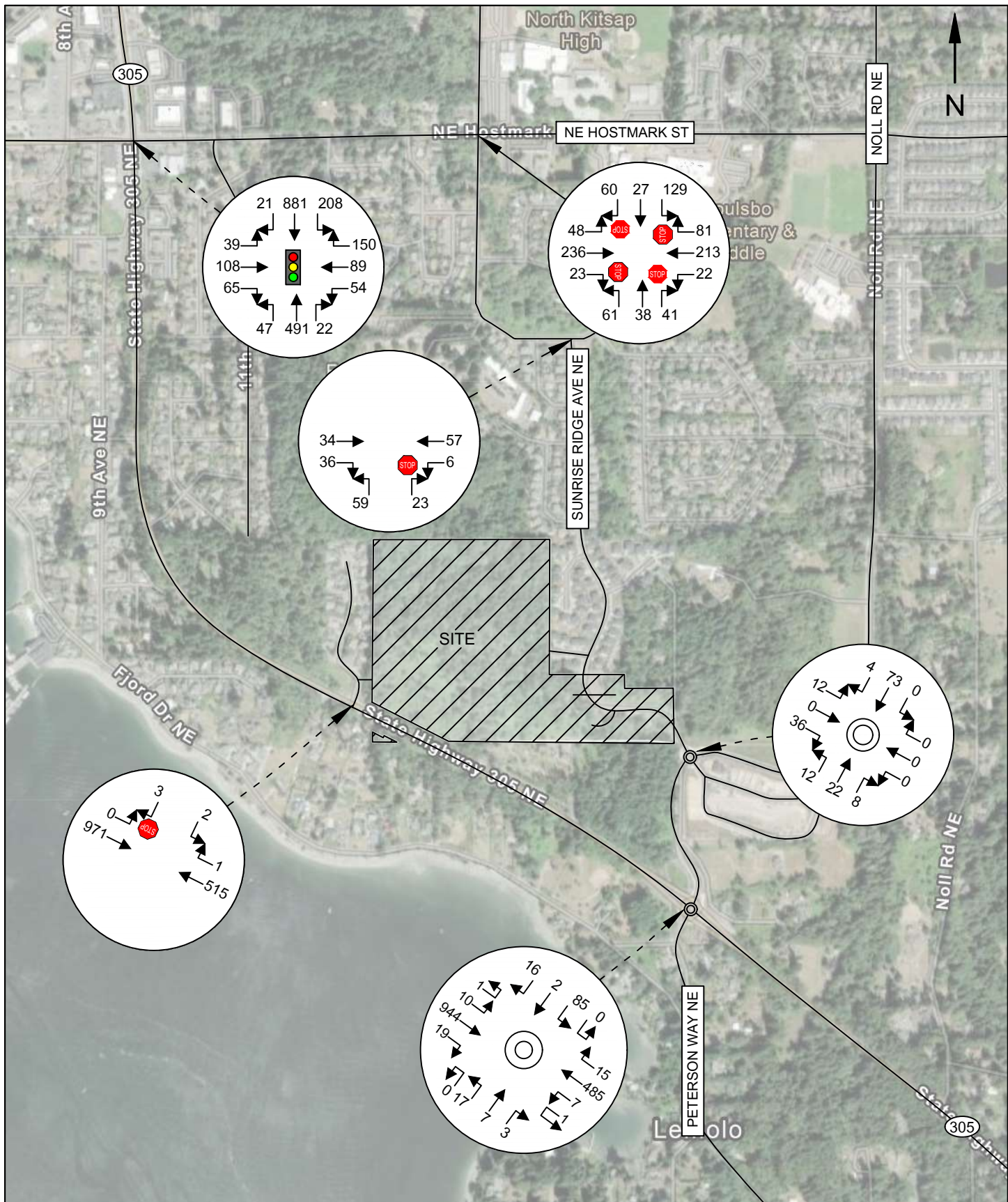

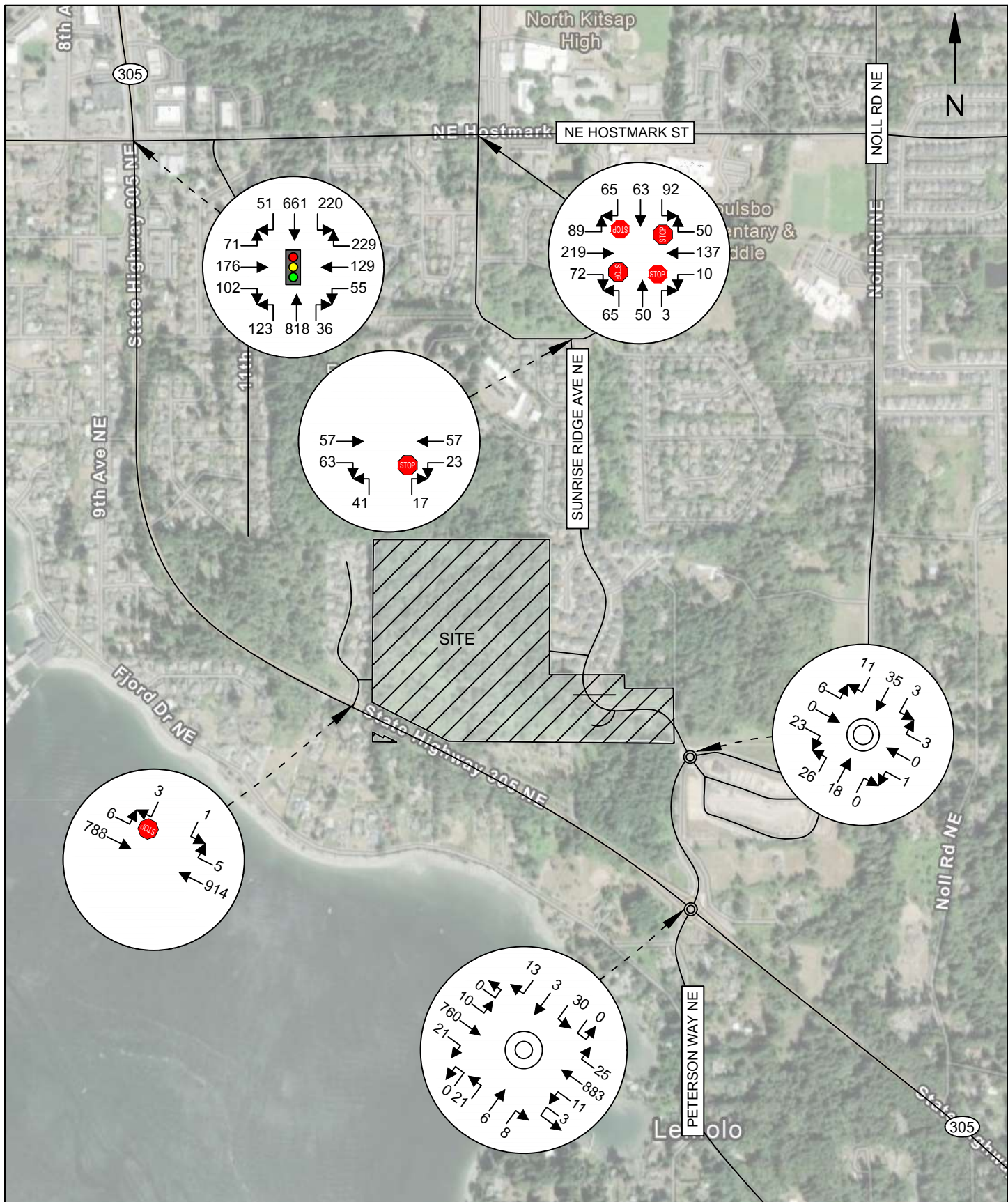

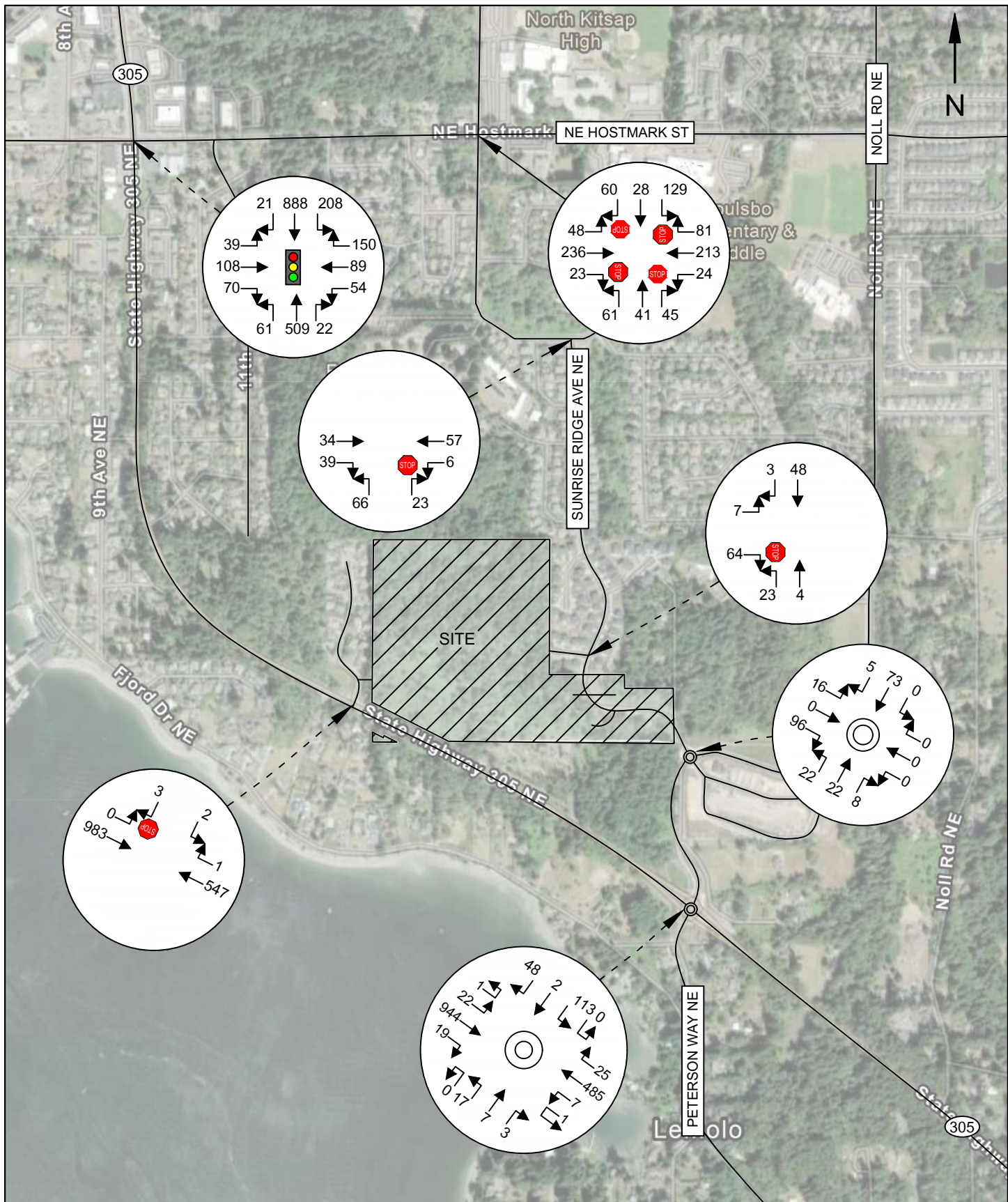

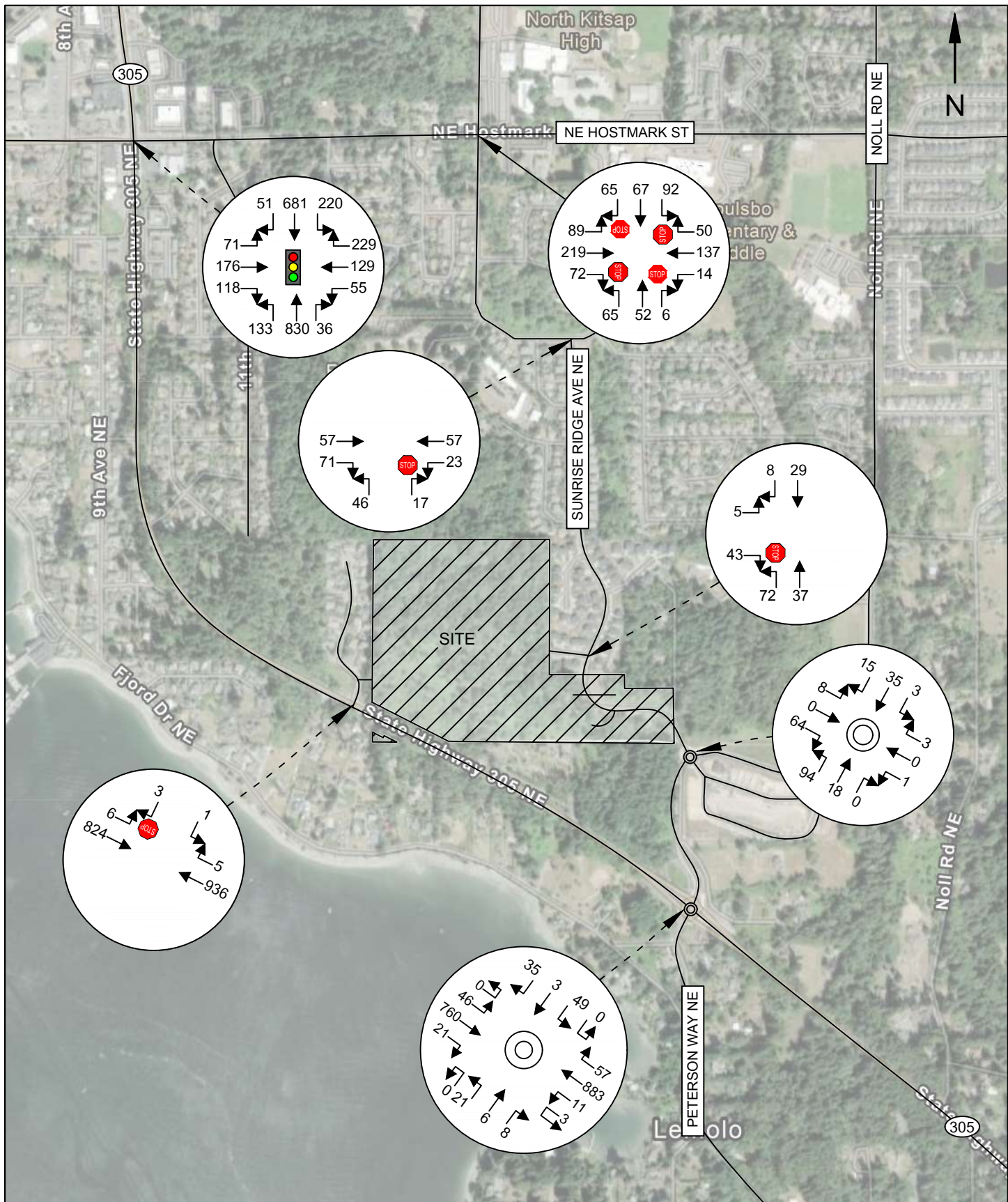

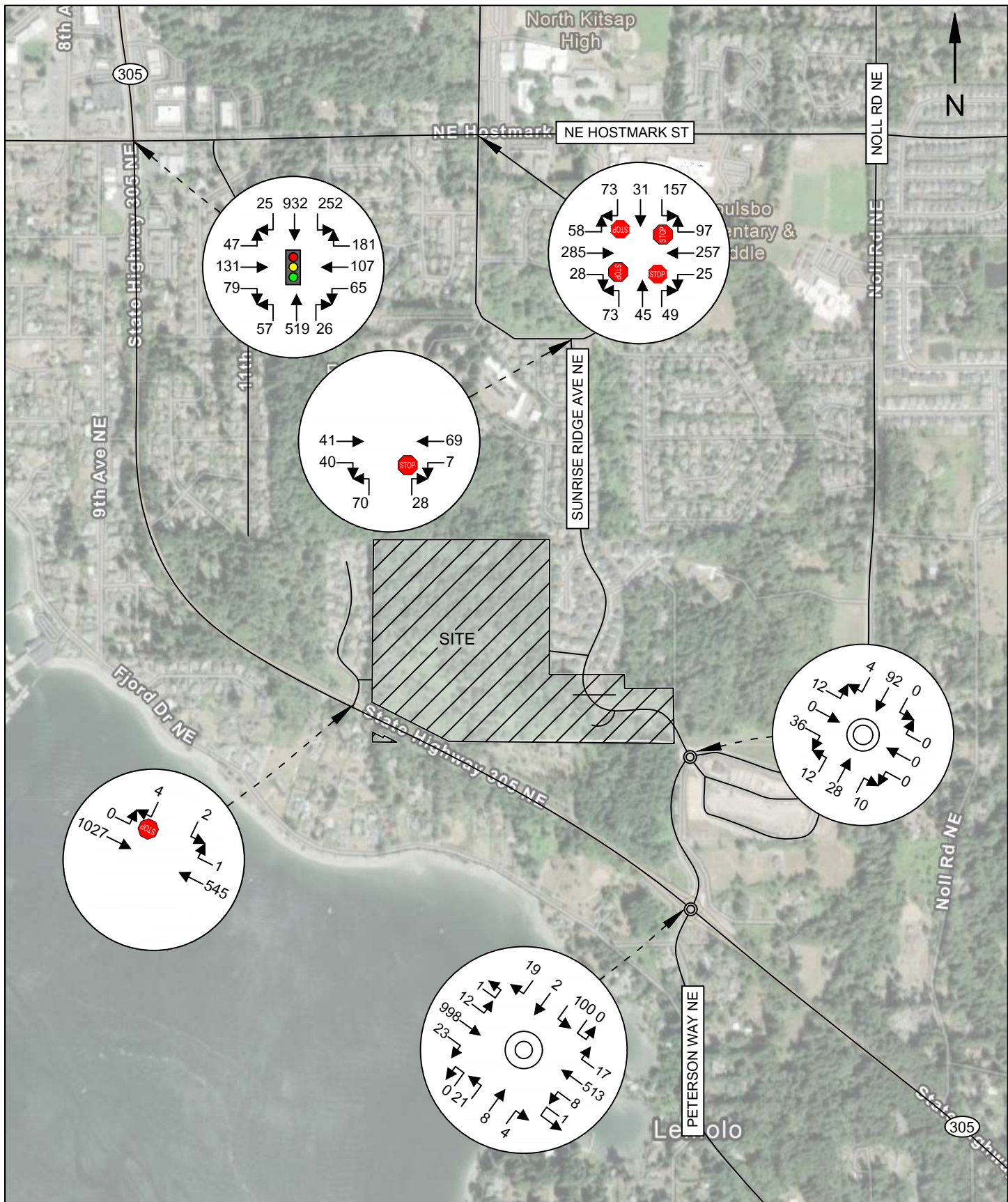

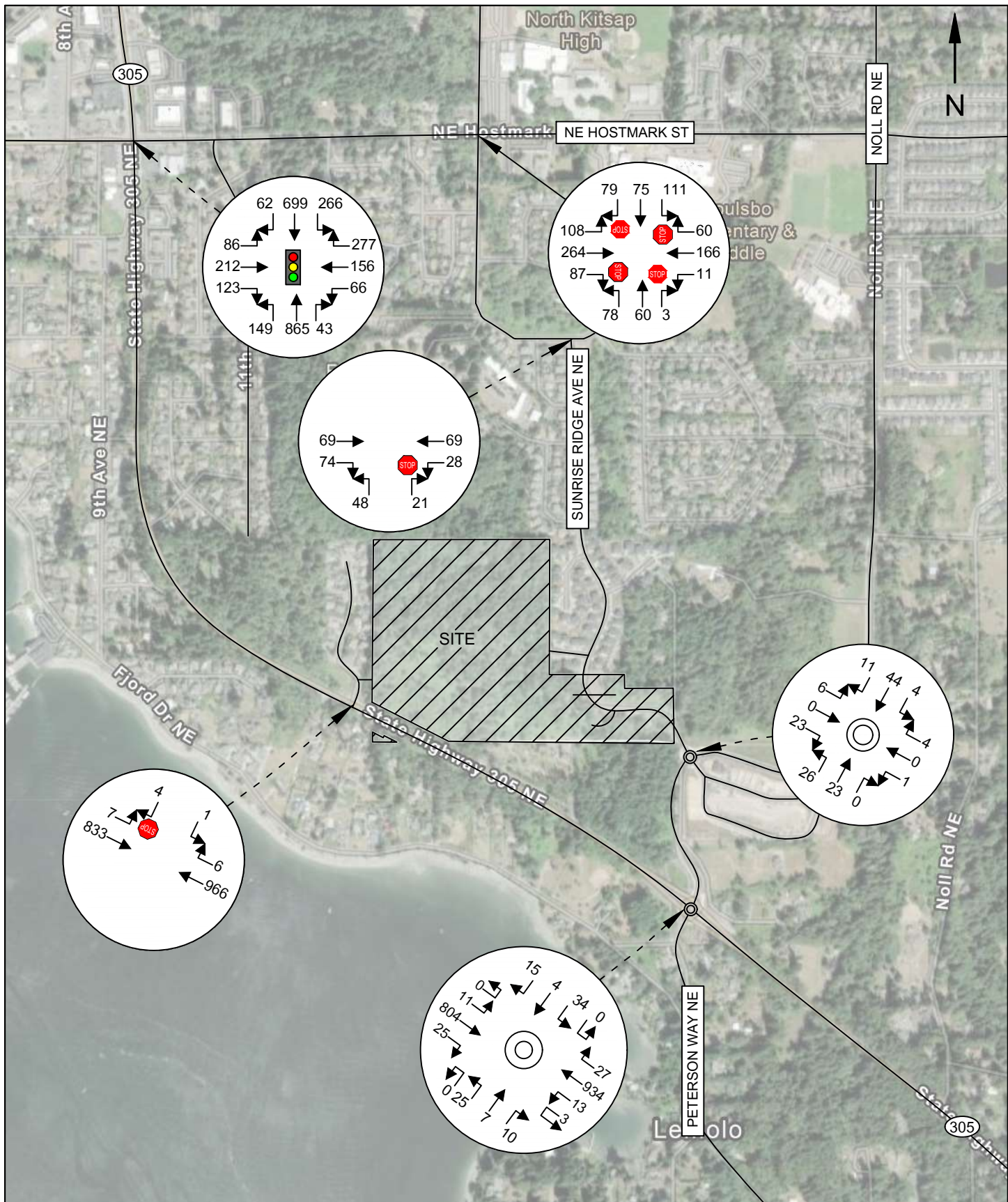

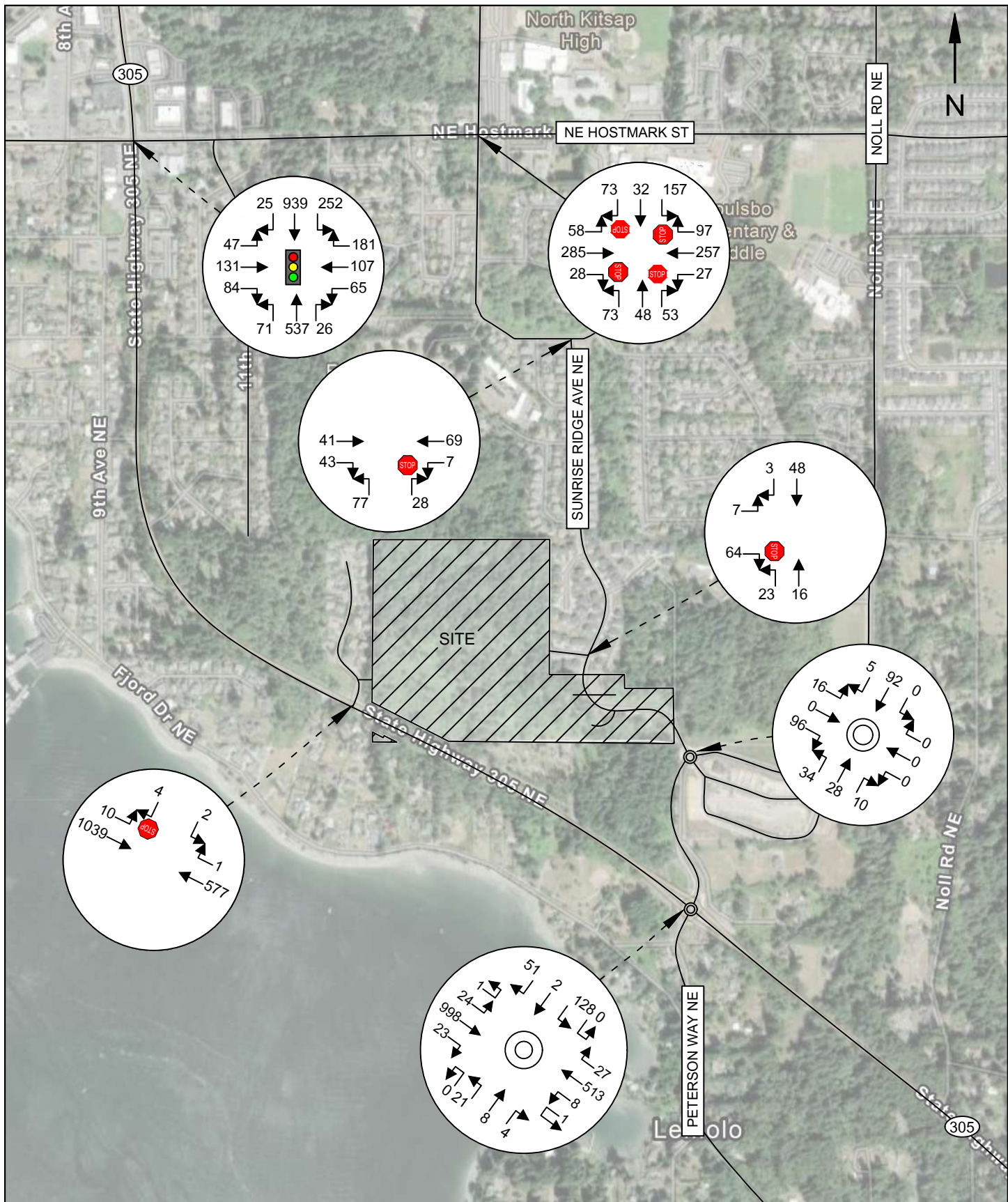

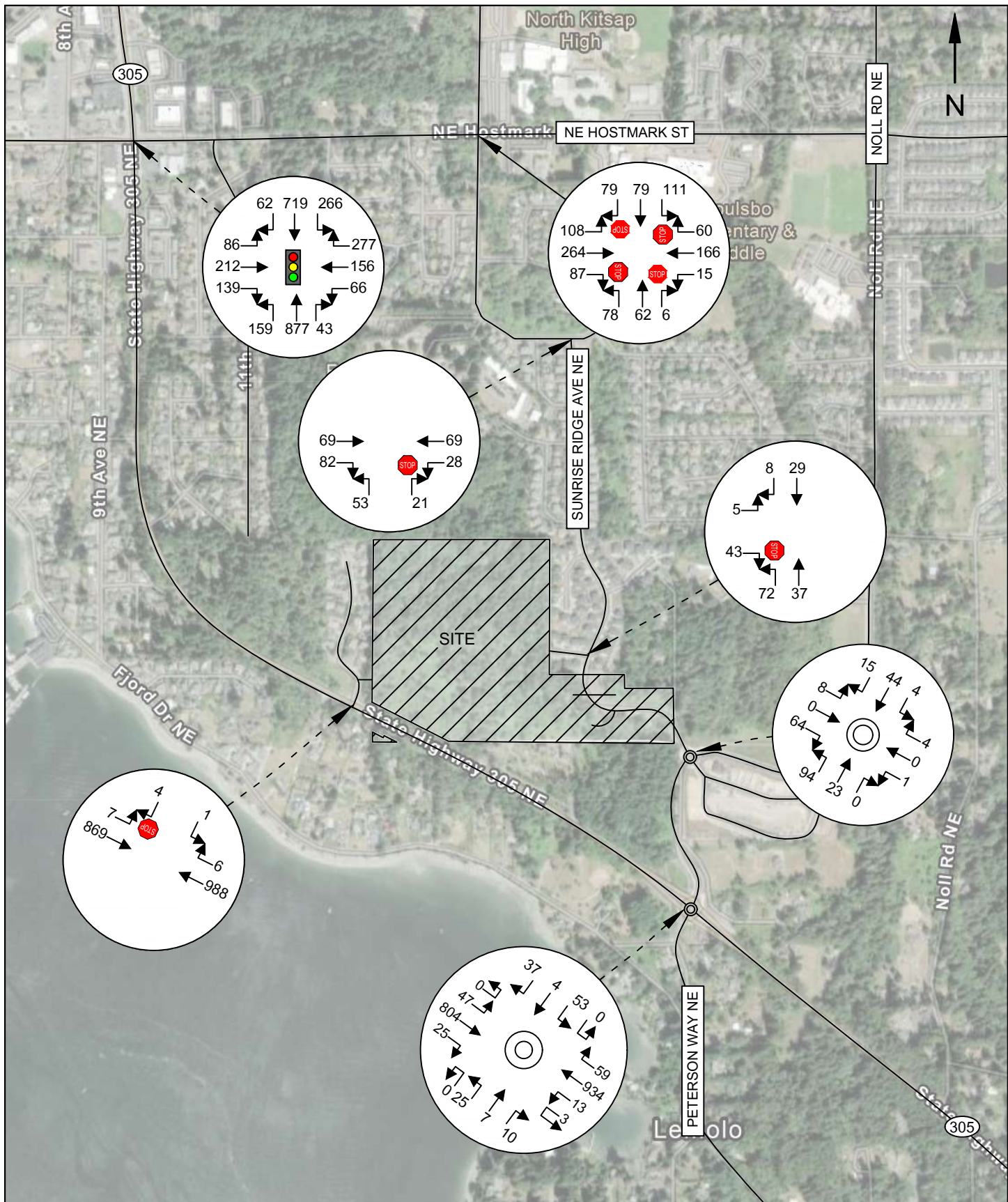

5.5 Project Access

Site access will be provided at four locations, as identified in Figure 2:

1. Access A: Sunrise Ridge Avenue via extension of Crystallia Court
2. Access B/C: Both sides of Sunrise Ridge Avenue 220 feet south of Crystallia Court
3. Access D: Sunrise Ridge Avenue 380 feet south of Crystallia Court

To provide a worst-case operations analysis, this study assumed project-generated trips will be consolidated at the primary access, Access A. The analysis indicates that the associated study intersection Sunrise Ridge Avenue NE & Crystallia Court will operate at LOS A through 2037, maintaining applicable WSDOT and City of Poulsbo minimum LOS standards.

Design of on-site streets, intersections, and frontage improvements should be coordinated with the City of Poulsbo.

5.6 Future Level of Service

Intersection LOS was analyzed for the 2032 and 2037 forecasting horizons both without and with project-generated trips. Intersection delay and LOS results are summarized in **Table 9**. The 2032 analysis assumed that existing Peak Hour Factor (PHF) would remain unchanged. The 2037 analysis applied a PHF of 1.0 on SR 305 intersections, consistent with WSDOT Synchro protocol for long-range analyses, while maintaining the counted 2025 PHFs on local intersections.

Hostmark Street & Caldart Avenue will degrade to LOS F in the 2037 AM Without Project scenario, below the City of Poulsbo minimum LOS E standard. The LOS deficiency is the result of school-related demand surge which was observed to occur for approximately 30 minutes during the weekday AM peak hour. The addition of project-generated trips will not significantly increase delay. The additional 1.3 seconds of delay per vehicle during the AM peak hour represents an increase of 2 percent relative to the without-project condition. 95th percentile queues are anticipated to extend 14-15 vehicles on the eastbound and westbound approaches in the 2037 AM peak hour and will not increase with the addition of project-generated trips. The project is not anticipated to generate a significant adverse impact, and no mitigation is recommended.



Table 9: Forecast 2032 & 2037 Weekday Peak Hour Level of Service

Delays Given in Seconds per Vehicle

Intersection	Control	Peak-Hour	Crt. Apprch	<i>Without Project</i>		<i>With Project</i>	
				LOS	Delay	LOS	Delay
Forecast 2032 Peak Hour Analysis							
SR 305 & Hostmark	Signal	AM	Overall	D	36.5	D	37.1
		PM		D	44.5	A	44.7
SR 305 & Baywatch	One-Way Stop	AM	SB	C	21.8	C	22.9
		PM		D	25.8	D	27.2
SR 305 & Johnson	RAB	AM	Overall	A	7.4	A	7.7
		PM		A	6.6	A	7.0
Hostmark & Caldart	AWSC	AM	Overall	C	22.6	C	24.2
		PM		B	14.9	C	15.1
Johnson Rd & Sunrise Ridge	RAB	AM	Overall	A	5.6	A	5.8
		PM		A	6.0	A	6.7
Caldart Ave & Sunrise Ridge	TWSC	AM	NB	A	9.7	A	9.8
		PM		B	10.0	B	10.1
Sunrise Ridge & Crystallia	One-Way Stop	AM	EB	--	--	A	8.7
		PM		--	--	A	8.7
Forecast 2037 Peak Hour Analysis							
SR 305 & Hostmark	Signal	AM	Overall	D	37.0	D	37.6
		PM		D	45.9	D	46.2
SR 305 & Baywatch	One-Way Stop	AM	SB	C	19.7	C	20.6
		PM		C	23.5	C	24.6
SR 305 & Johnson	RAB	AM	Overall	A	7.5	A	7.8
		PM		A	6.7	A	7.0
Hostmark & Caldart	AWSC	AM	Overall	F	61.9	F	63.2
		PM		D	26.1	D	27.1
Johnson Rd & Sunrise Ridge	RAB	AM	Overall	A	5.5	A	5.8
		PM		A	5.9	A	6.6
Caldart & Sunrise Ridge	TWSC	AM	NB	A	9.9	B	10.0
		PM		B	10.4	B	10.5
Sunrise Ridge & Crystallia	One-Way Stop	AM	EB	--	--	A	8.7
		PM		--	--	A	8.7
*Signalized intersection LOS is based on overall intersection delay; Roundabout (RAB) and AWSC LOS is based on overall intersection delay and stop-controlled delay thresholds; Minor-approach stop control LOS is based on worst-approach delay and stop-controlled delay thresholds							



SR 305 & Baywatch Court NE will operate acceptably at LOS D or better through 2037, with average delay of 27 seconds or less on southbound approach. The southbound left-turn movement will operate at LOS F in all future PM peak hour scenarios; however, project-generated trips are not anticipated to utilize Baywatch Court NE. 95th percentile queues are anticipated to extend no more than one car-length through 2037 before and after project trips. SR 305 & Baywatch Court NE delay forecasts are slightly lower in 2037 than 2032 due to the application of a 1.0 PHF on SR 305 intersections in the long-range forecasting horizon, consistent with WSDOT Synchro protocol.

All other intersections will operate at LOS D or better, satisfying their respective minimum City and WSDOT LOS standards through 2037.

5.7 SR 305 Connectivity

Project trips will access SR 305 to the south of the site via the SR 305 & Johnson Road roundabout intersection or to the northwest of the site via the SR 305 & NE Hostmark Road signalized intersection. A previous draft TIA report included an additional connection via Baywatch Court NE, a local access street to the southwest of the subject site which intersects SR 305 at a minor-approach stop-controlled intersection.

This analysis indicates that the existing street network, including the intersections of SR 305 at Johnson Road and at Hostmark Street, provide adequate capacity to support project trips through the 2037 analysis horizon.

The revised site plan eliminates project trips on Baywatch Court NE, reducing traffic volume on the local access street and potentially improving safety at the stop-controlled SR 305 intersection by reducing vehicle conflicts.



5.8 Construction Traffic

Truck activity will vary throughout project construction, with an estimated maximum of 60-80 trucks per day during a 3-4-week mass grading and import phase. Construction activity will involve a maximum of 20 on-site construction employees.

Construction traffic is anticipated to primarily utilize Johnson Road, a City arterial, to access SR 305, a state route. The anticipated construction route is illustrated in **Figure 21**. Any route restrictions or preferences can be coordinated with the City.

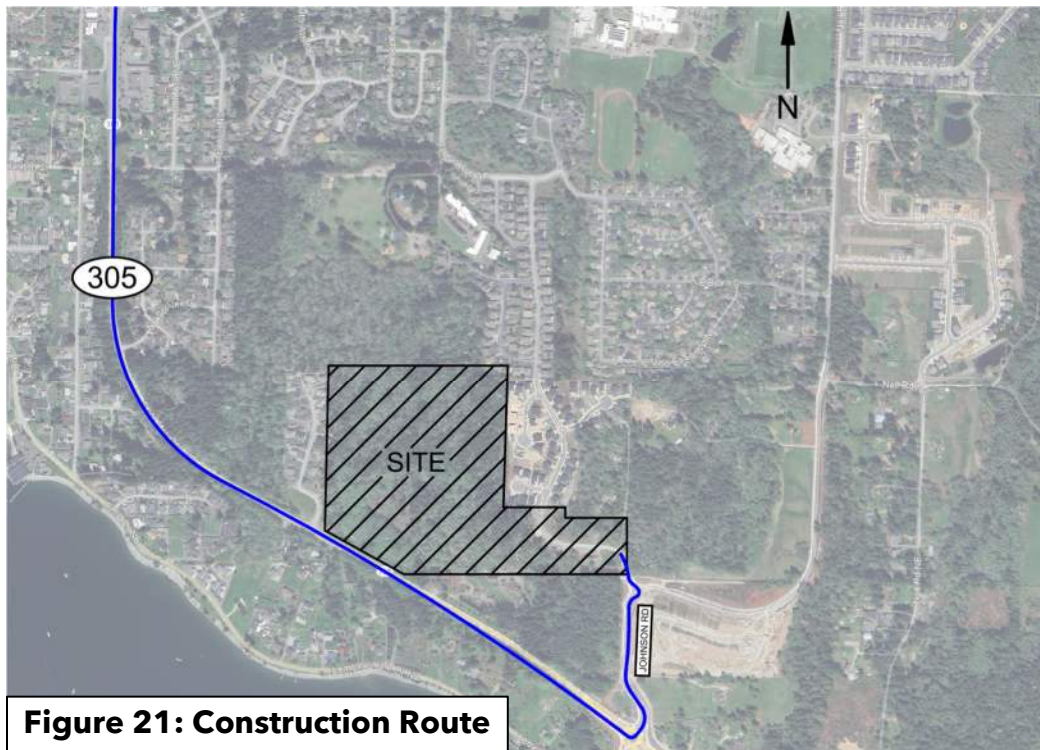

Figure 21: Construction Route



6. CONCLUSIONS & MITIGATION

The Pinnacle at Liberty Bay is a proposed residential development consisting of 138 single-family homes located within Poulsbo. The subject site comprises 40.98 acres on four undeveloped tax parcels. Site ingress/egress is proposed via NE Crystallia Court and Sunrise Ridge Avenue NE.

Existing traffic operations were analyzed at six intersections in the project vicinity. All study intersections currently operate at LOS D or better, satisfying WSDOT and City of Poulsbo minimum LOS standards. A crash history analysis indicated no serious injury or fatal crashes in the study area and no safety deficiencies were identified.

The project is anticipated to generate 1,254 average weekday daily trips, 97 AM peak hour trips, and 128 PM peak hour trips. Future pipeline growth in the study area will include three nearby residential developments. Additional background traffic growth was forecast using travel demand forecasts provided by the City of Poulsbo.

Future traffic conditions were analyzed for 2032 and 2037 horizon years. Traffic forecasts assumed completion of the Sunrise Ridge Avenue NE connection between Noll Road and Caldart Avenue, including redistribution of travel demand.

The traffic operations forecasts indicated that the intersection of Hostmark Street & Caldart Avenue will operate at LOS F in the 2037 AM Without Project scenario, below the City of Poulsbo minimum LOS E standard. The LOS deficiency is the result of a school-related demand surge which was observed to occur for approximately 30 minutes during the AM peak hour. The addition of project-generated trips will not significantly increase delay and no mitigation is recommended.

All other intersections will operate at LOS D or better, satisfying their respective minimum City and WSDOT LOS standards through 2037.

Construction activity will vary over the anticipated 12-month construction period. Trucks are encouraged to utilize state routes and should coordinate preferred truck routes with the City of Poulsbo.



The following mitigation recommendations are provided for consideration:

1. Design of on-site streets, intersections, and frontage improvements should be coordinated with the City of Poulsbo.
2. The project will be subject to Traffic Impact Fees (TIF) as imposed by the City of Poulsbo (PMC 3.86). Fees are based on project-generated trips, assessed at \$564.00 per net new daily trip. The estimated fee calculation is:

$$1,254 \text{ daily trips} \times \$564.00 \text{ per daily trip} = \mathbf{\$707,256.00}$$

Traffic impact fees will be calculated and determined by the City at the time of building permit issuance.

No other mitigation is recommended.



THE PINNACLE AT LIBERTY BAY TRAFFIC IMPACT ANALYSIS

APPENDIX Traffic Counts



NE Hostmark Street & SR 305

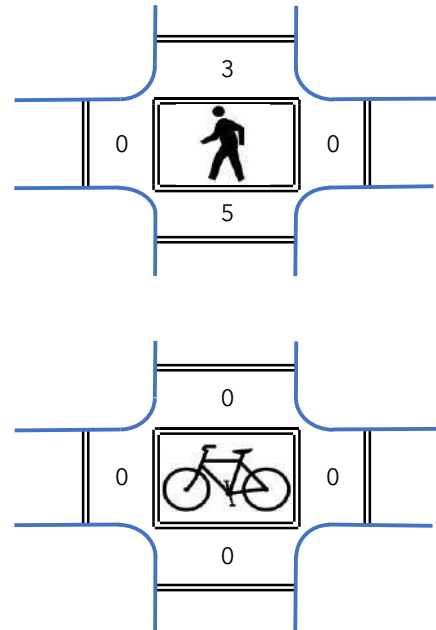
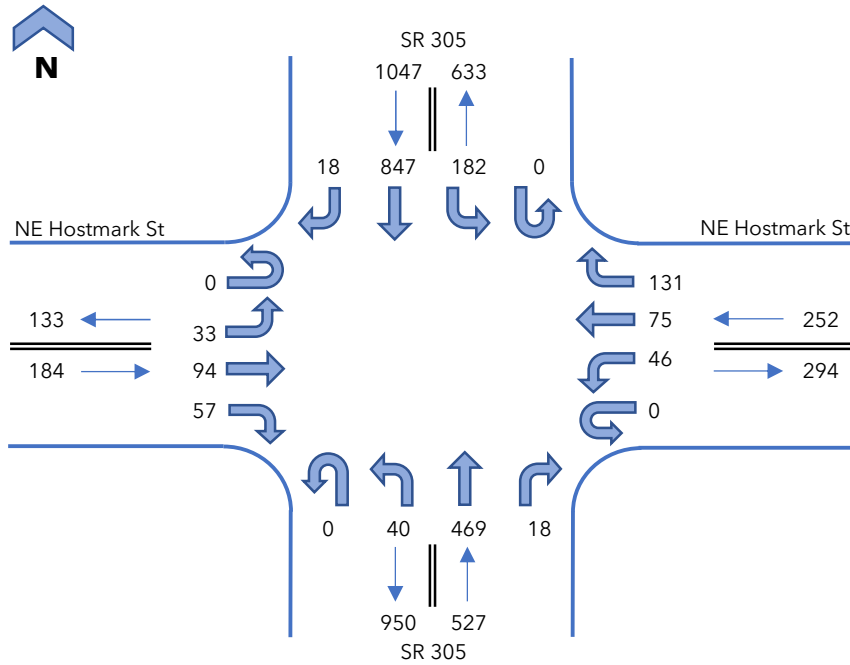

Interval Start Time	NE Hostmark St Eastbound				NE Hostmark St Westbound				SR 305 Northbound				SR 305 Southbound				15 Minute Totals	Hourly Totals	
	UT	LT	T	RT	UT	LT	T	RT	UT	LT	T	RT	UT	LT	T	RT			
	7:00 AM	0	2	12	9	0	5	12	26	0	5	110	1	0	28	200			5
7:15 AM	0	11	29	18	0	19	16	29	0	6	111	4	0	50	226	4	523		
7:30 AM	0	12	30	14	0	10	19	41	0	12	111	7	0	64	200	5	525		
7:45 AM	0	8	23	16	0	12	28	35	0	17	137	6	0	40	221	4	547		
8:00 AM	0	12	7	11	0	5	17	24	0	9	118	6	0	17	180	6	412	2007	
8:15 AM	0	11	11	9	0	7	14	24	0	9	128	5	0	12	180	3	413	1897	
8:30 AM	0	8	14	10	0	7	13	19	0	21	122	7	0	30	168	7	426	1798	
8:45 AM	0	9	15	14	0	12	13	33	0	8	150	7	0	23	163	6	453	1704	
Count Total	0	73	141	101	0	77	132	231	0	87	987	43	0	264	1538	40	3714	--	
Peak Hour Total	0	33	94	57	0	46	75	131	0	40	469	18	0	182	847	18	2010	--	
PHF	0.79				0.84				0.82				0.93				0.92	--	
Heavy Vehicles	0	2	5	2	0	2	3	8	0	2	27	1	0	9	53	2	116	--	
HV %	0.0%	6.1%	5.3%	3.5%	0.0%	4.3%	4.0%	6.1%	0.0%	5.0%	5.8%	5.6%	0.0%	4.9%	6.3%	11.1%	5.8%	--	

Interval Start Time	Heavy Vehicles				
	EB	WB	NB	SB	Total
7:00 AM	2	1	7	10	20
7:15 AM	4	3	10	15	32
7:30 AM	2	7	2	22	33
7:45 AM	1	2	11	17	31
8:00 AM	4	3	5	20	32
8:15 AM	3	3	9	16	31
8:30 AM	1	2	11	22	36
8:45 AM	3	3	10	13	29
Count Total	20	24	65	135	244
Peak Hour Total	9	13	30	64	116
Peak Hour HV%	4.9%	5.2%	5.7%	6.1%	5.8%

Pedestrians (Leg)				
E	W	N	S	Total
0	0	1	3	4
0	0	1	0	1
0	0	0	1	1
0	0	1	1	2
0	1	0	1	2
0	0	2	1	3
2	2	3	2	9
0	0	2	2	4
2	3	10	11	26
0	0	3	5	8

Bicycles (Leg)				
E	W	N	S	Total
0	0	0	0	0
0	0	0	0	0
0	0	0	0	0
0	0	0	0	0
0	0	0	0	0
0	0	0	0	0
0	0	0	0	0
0	0	0	0	0
0	0	0	0	0
0	0	0	0	0

NE Hostmark Street & SR 305

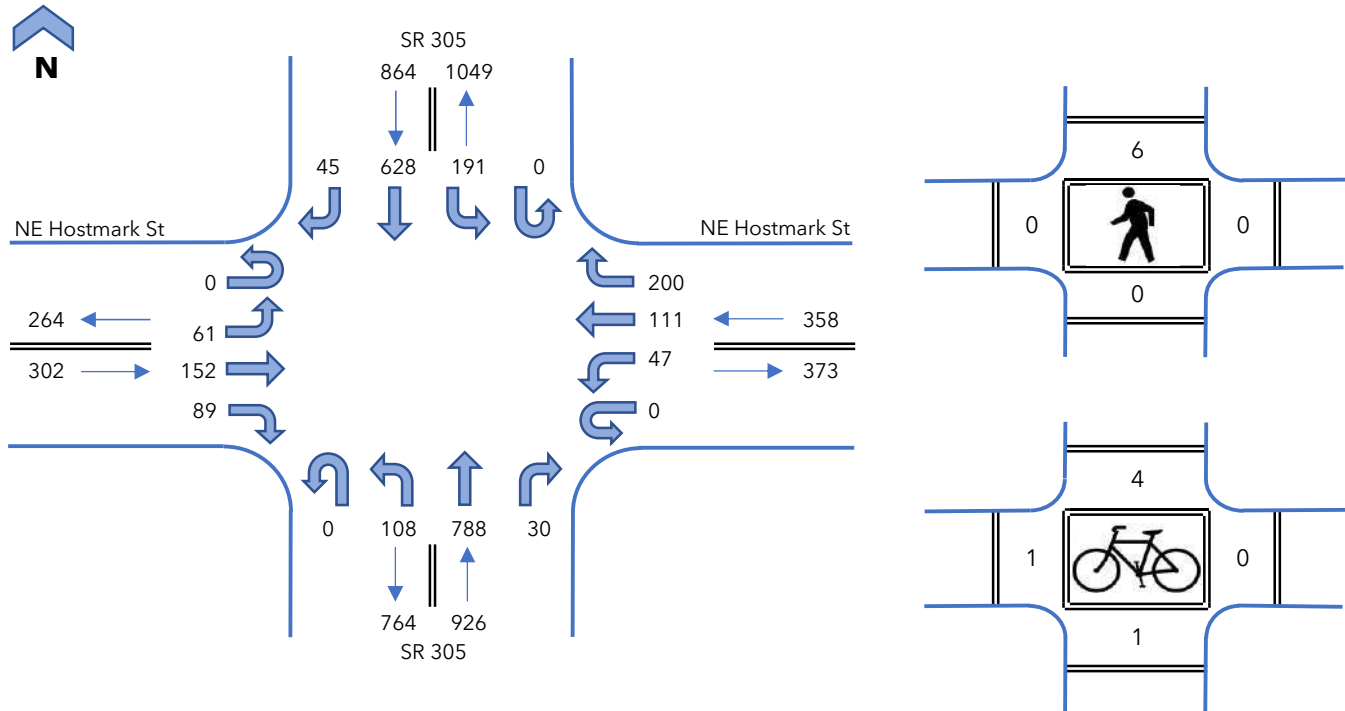

Interval Start Time	NE Hostmark St Eastbound				NE Hostmark St Westbound				SR 305 Northbound				SR 305 Southbound				15 Minute Totals	Hourly Totals
	UT	LT	T	RT	UT	LT	T	RT	UT	LT	T	RT	UT	LT	T	RT		
	4:00 PM	0	19	39	16	0	12	25	48	0	21	205	5	0	49	164		
4:15 PM	0	13	34	27	0	15	23	47	0	31	191	12	0	52	146	12	603	
4:30 PM	0	13	43	24	0	9	41	62	0	28	182	5	0	43	150	15	615	
4:45 PM	0	16	36	22	0	11	22	43	0	28	210	8	0	47	168	6	617	
5:00 PM	0	12	40	30	0	4	26	31	0	20	169	4	0	54	173	9	572	
5:15 PM	0	11	23	21	0	2	24	31	1	28	175	7	0	51	160	7	541	
5:30 PM	0	20	38	14	0	7	13	27	0	17	216	6	0	38	149	14	559	
5:45 PM	0	16	22	15	0	6	17	16	0	23	191	7	0	48	137	12	510	
Count Total	0	120	275	169	0	66	191	305	1	196	1539	54	0	382	1247	87	4632	--
Peak Hour Total	0	61	152	89	0	47	111	200	0	108	788	30	0	191	628	45	2450	--
PHF	0.94				0.80				0.94				0.96				0.99	--
Heavy Vehicles	0	4	4	1	0	0	1	2	0	2	30	0	0	2	11	2	59	--
HV %	0.0%	6.6%	2.6%	1.1%	0.0%	0.0%	0.9%	1.0%	0.0%	1.9%	3.8%	0.0%	0.0%	1.0%	1.8%	4.4%	2.4%	--

Interval Start Time	Heavy Vehicles				
	EB	WB	NB	SB	Total
4:00 PM	1	1	4	2	8
4:15 PM	0	1	9	1	11
4:30 PM	3	0	15	6	24
4:45 PM	5	1	4	6	16
5:00 PM	0	4	3	5	12
5:15 PM	0	0	8	4	12
5:30 PM	0	0	9	2	11
5:45 PM	2	0	9	1	12
Count Total	11	7	61	27	106
Peak Hour Total	9	3	32	15	59
Peak Hour HV%	3.0%	0.8%	3.5%	1.7%	2.4%

Pedestrians (Leg)				
E	W	N	S	Total
0	0	4	0	4
0	0	1	0	1
0	0	0	0	0
0	0	1	0	1
0	1	0	3	4
1	1	1	1	4
0	0	3	2	5
1	0	5	1	7
2	2	15	7	26
0	0	6	0	6

Bicycles (Leg)				
E	W	N	S	Total
0	0	0	0	0
0	0	3	0	3
0	0	0	0	0
0	1	1	1	3
0	0	0	0	0
0	0	0	0	0
0	0	0	0	0
0	0	0	0	0
0	1	4	1	6
0	1	4	1	6

SR 305 & Baywatch Court NE

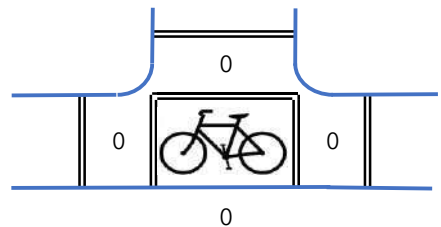
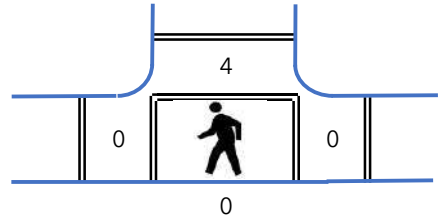
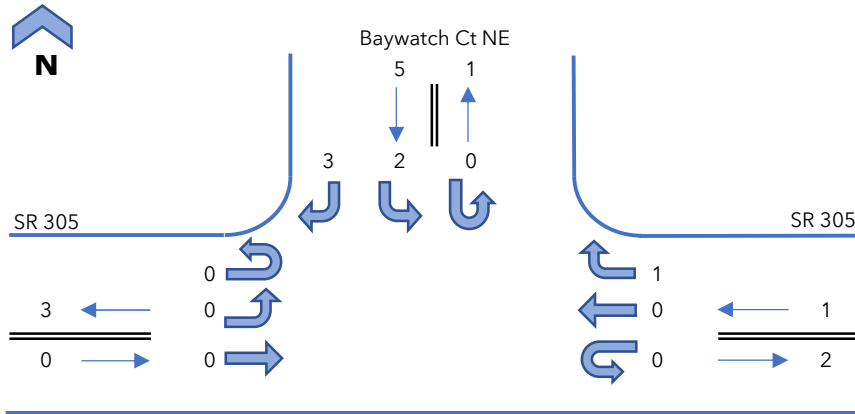

Interval Start Time	SR 305 Eastbound				SR 305 Westbound				Baywatch Ct NE Southbound				15 Minute Totals	Hourly Totals				
	UT	LT	T	RT	UT	LT	T	RT	UT	LT	T	RT						
	7:00 AM	0	0	0	--	0	--	0	0	--	--	--			--	0	0	--
7:15 AM	0	0	0	--	0	--	0	0	--	--	--	--	0	0	--	0		
7:30 AM	0	0	0	--	0	--	0	0	--	--	--	--	0	1	--	1	2	
7:45 AM	0	0	0	--	0	--	0	0	--	--	--	--	0	0	--	0	0	
8:00 AM	0	0	0	--	0	--	0	0	--	--	--	--	0	0	--	0	0	
8:15 AM	0	0	0	--	0	--	0	0	--	--	--	--	0	1	--	1	2	
8:30 AM	0	0	0	--	0	--	0	0	--	--	--	--	0	1	--	0	1	
8:45 AM	0	0	0	--	0	--	0	1	--	--	--	--	0	0	--	2	3	
Count Total	0	0	0	--	0	--	0	1	--	--	--	--	0	3	--	5	9	
Peak Hour Total	0	0	0	--	0	--	0	1	--	--	--	--	0	2	--	3	6	
PHF	#DIV/0!				0.25				--				0.63				0.50	--
Heavy Vehicles	0	0	0	--	0	--	0	0	--	--	--	--	0	0	--	0	0	
HV %	0.0%	0.0%	0.0%	--	0.0%	--	0.0%	0.0%	--	--	--	--	0.0%	0.0%	--	0.0%	0.0%	

Interval Start Time	Heavy Vehicles				
	EB	WB	NB	SB	Total
7:00 AM	0	0	--	0	0
7:15 AM	0	0	--	0	0
7:30 AM	0	0	--	0	0
7:45 AM	0	0	--	0	0
8:00 AM	0	0	--	0	0
8:15 AM	0	0	--	0	0
8:30 AM	0	0	--	0	0
8:45 AM	0	0	--	0	0
Count Total	0	0	--	0	0
Peak Hour Total	0	0	--	0	0
Peak Hour HV%	0.0%	0.0%	--	0.0%	0.0%

Interval Start Time	Pedestrians (Leg)				
	E	W	N	S	Total
7:00 AM	0	0	0	0	0
7:15 AM	0	0	0	0	0
7:30 AM	0	0	0	0	0
7:45 AM	0	0	0	0	0
8:00 AM	0	0	0	0	0
8:15 AM	0	0	4	0	4
8:30 AM	0	0	0	0	0
8:45 AM	0	0	0	0	0
Count Total	0	0	4	0	4
Peak Hour Total	0	0	4	0	4

Interval Start Time	Bicycles (Leg)				
	E	W	N	S	Total
7:00 AM	0	0	0	0	0
7:15 AM	0	0	0	0	0
7:30 AM	0	0	0	0	0
7:45 AM	0	0	0	0	0
8:00 AM	0	0	0	0	0
8:15 AM	0	0	0	0	0
8:30 AM	0	0	0	0	0
8:45 AM	0	0	0	0	0
Count Total	0	0	0	0	0
Peak Hour Total	0	0	0	0	0

SR 305 & Baywatch Court NE

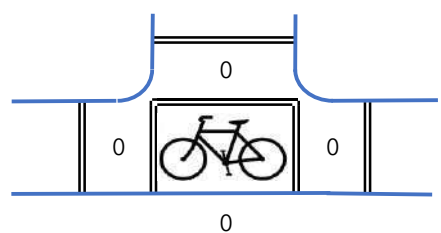
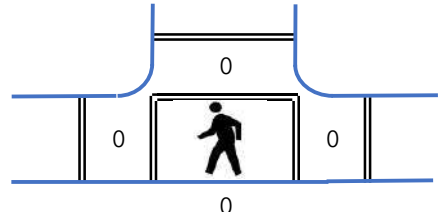
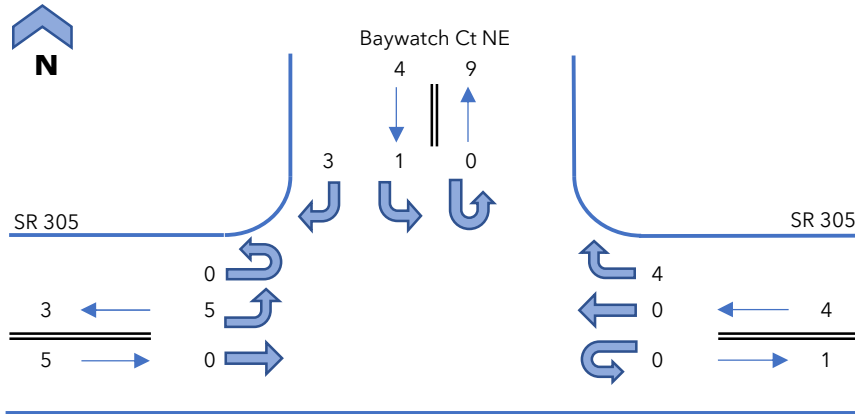

Interval Start Time	SR 305 Eastbound				SR 305 Westbound				Baywatch Ct NE Southbound				15 Minute Totals	Hourly Totals	
	UT	LT	T	RT	UT	LT	T	RT	UT	LT	T	RT			
	4:00 AM	0	0	0	--	0	--	0	0	--	--	--			--
4:15 AM	0	0	0	--	0	--	0	0	--	--	--	--	0	0	0
4:30 AM	0	0	0	--	0	--	0	0	--	--	--	--	0	0	1
4:45 AM	0	1	0	--	0	--	0	2	--	--	--	--	0	0	3
5:00 AM	0	3	0	--	0	--	0	0	--	--	--	--	0	0	4
5:15 AM	0	1	0	--	0	--	0	2	--	--	--	--	0	1	5
5:30 AM	0	0	0	--	0	--	0	1	--	--	--	--	0	0	1
5:45 AM	0	0	0	--	0	--	0	1	--	--	--	--	0	0	1
Count Total	0	5	0	--	0	--	0	6	--	--	--	--	0	1	15
Peak Hour Total	0	5	0	--	0	--	0	4	--	--	--	--	0	1	13
PHF	0.42				0.50				--				0.65	--	
Heavy Vehicles	0	1	0	--	0	--	0	0	--	--	--	--	0	1	2
HV %	0.0%	20.0%	0.0%	--	0.0%	--	0.0%	0.0%	--	--	--	--	0.0%	100.0%	15.4%

Interval Start Time	Heavy Vehicles				
	EB	WB	NB	SB	Total
4:00 AM	0	0	--	0	0
4:15 AM	0	0	--	0	0
4:30 AM	0	0	--	0	0
4:45 AM	0	0	--	0	0
5:00 AM	1	0	--	0	1
5:15 AM	0	0	--	1	1
5:30 AM	0	0	--	0	0
5:45 AM	0	0	--	0	0
Count Total	1	0	--	1	2
Peak Hour Total	1	0	--	1	2
Peak Hour HV%	20.0%	0.0%	--	25.0%	15.4%

Pedestrians (Leg)				
E	W	N	S	Total
0	0	1	0	1
0	0	0	0	0
0	0	0	0	0
0	0	0	0	0
0	0	0	0	0
0	0	0	0	0
0	0	0	0	0
0	0	0	0	0
0	0	0	0	0
0	0	1	0	1
0	0	0	0	0

Bicycles (Leg)				
E	W	N	S	Total
0	0	0	0	0
0	0	0	0	0
0	0	0	0	0
0	0	0	0	0
0	0	0	0	0
0	0	0	0	0
0	0	0	0	0
0	0	0	0	0
0	0	0	0	0
0	0	0	0	0
0	0	0	0	0

SR 305 & Johnson Parkway NE

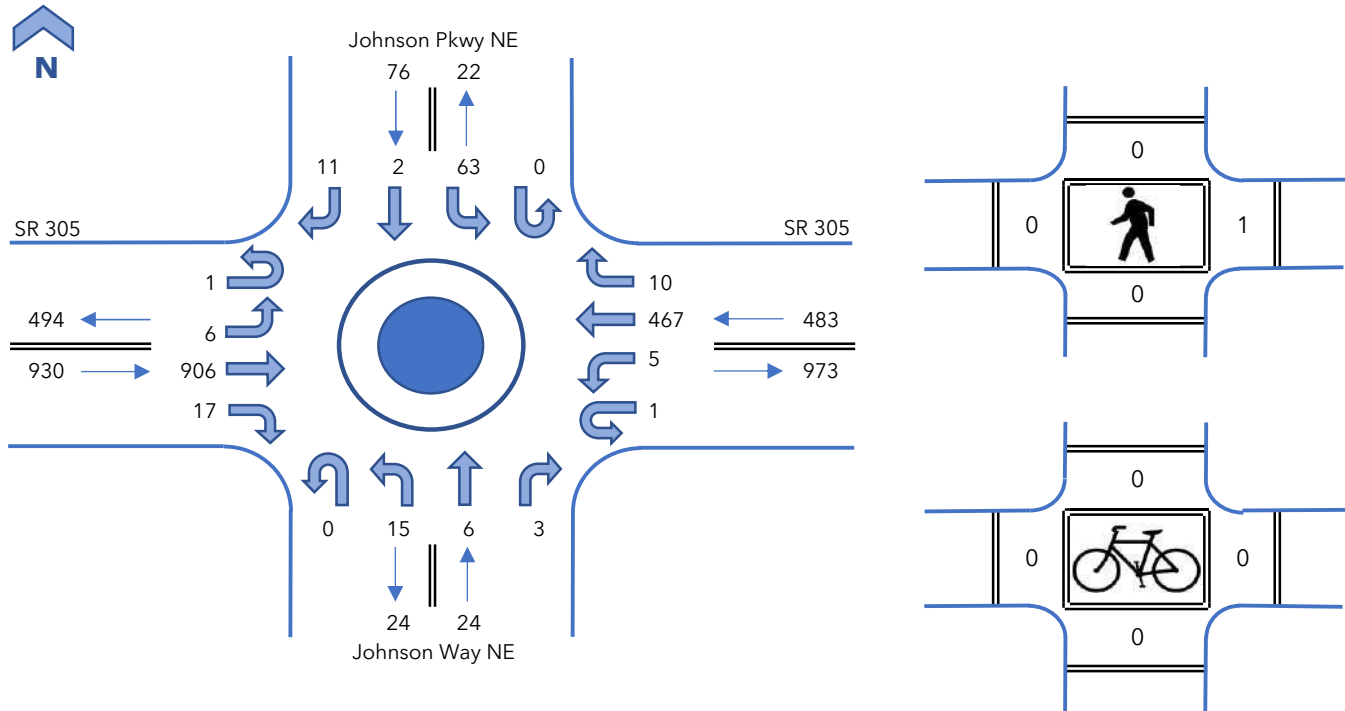

Interval Start Time	SR 305 Eastbound				SR 305 Westbound				Johnson Way NE Northbound				Johnson Pkwy NE Southbound				15 Minute Totals	Hourly Totals
	UT	LT	T	RT	UT	LT	T	RT	UT	LT	T	RT	UT	LT	T	RT		
	7:00 AM	0	0	207	0	0	0	120	1	0	8	1	0	0	10	0		
7:15 AM	0	5	271	4	0	1	100	4	0	2	0	2	0	16	0	1	406	
7:30 AM	1	1	199	6	1	4	127	3	0	1	4	1	1	15	1	4	369	
7:45 AM	0	0	229	7	0	0	120	2	0	4	1	0	0	22	1	4	390	1514
8:00 AM	0	2	184	5	1	2	131	2	0	4	2	1	0	10	3	2	349	1514
8:15 AM	1	1	187	6	1	1	136	1	0	4	2	1	0	2	1	2	346	1454
8:30 AM	2	4	168	4	1	0	119	3	0	5	1	0	0	7	0	3	317	1402
8:45 AM	0	2	158	5	0	3	165	4	0	4	2	0	0	2	0	5	350	1362
Count Total	4	15	1603	37	4	11	1018	20	0	32	13	5	1	84	6	23	2876	--
Peak Hour Total	1	6	906	17	1	5	467	10	0	15	6	3	1	63	2	11	1514	--
PHF	0.83				0.89				0.67				0.71				0.93	--
Heavy Vehicles	0	1	70	2	0	0	27	0	0	0	0	0	1	2	0	0	103	--
HV %	0.0%	16.7%	7.7%	11.8%	0.0%	0.0%	5.8%	0.0%	0.0%	0.0%	0.0%	0.0%	100.0%	3.2%	0.0%	0.0%	6.8%	--

Interval Start Time	Heavy Vehicles				
	EB	WB	NB	SB	Total
7:00 AM	7	6	0	0	13
7:15 AM	11	8	0	0	19
7:30 AM	18	6	0	2	26
7:45 AM	25	7	0	1	33
8:00 AM	19	5	0	0	24
8:15 AM	15	6	2	1	24
8:30 AM	20	8	0	2	30
8:45 AM	15	11	0	0	26
Count Total	130	57	2	6	195
Peak Hour Total	73	27	0	3	103
Peak Hour HV%	7.8%	5.6%	0.0%	3.9%	6.8%

Pedestrians (Leg)				
E	W	N	S	Total
0	0	0	0	0
0	0	0	0	0
0	0	0	0	0
1	0	0	0	1
0	0	0	0	0
0	0	0	0	0
0	0	0	0	0
0	0	0	0	0
1	0	0	0	1
1	0	0	0	1

Bicycles (Leg)				
E	W	N	S	Total
0	0	0	0	0
0	0	0	0	0
0	0	0	0	0
0	0	0	0	0
0	0	0	0	0
0	0	0	0	0
0	0	0	0	0
0	0	0	0	0
0	0	0	0	0
0	0	0	0	0

SR 305 & Johnson Parkway NE

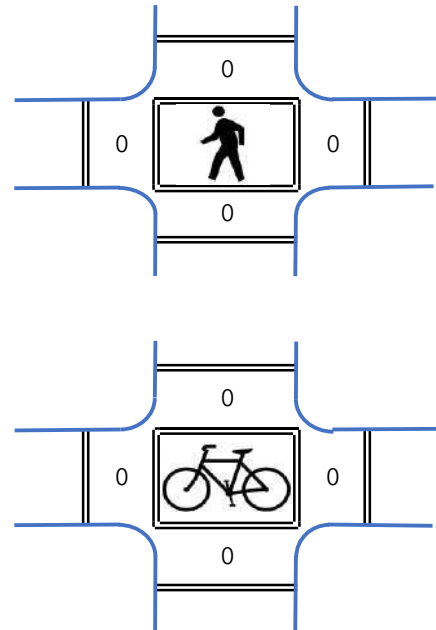
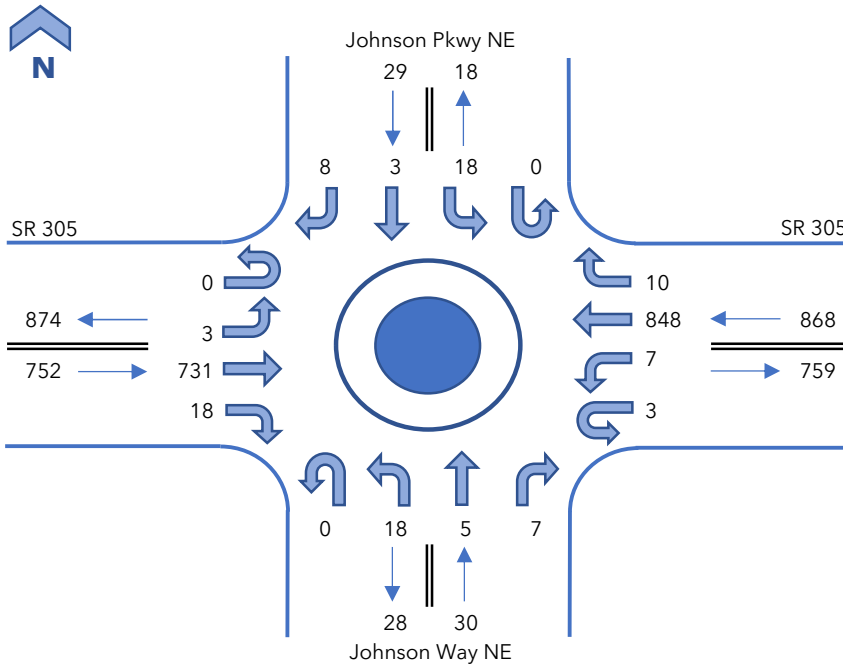

Interval Start Time	SR 305 Eastbound				SR 305 Westbound				Johnson Way NE Northbound				Johnson Pkwy NE Southbound				15 Minute Totals	Hourly Totals
	UT	LT	T	RT	UT	LT	T	RT	UT	LT	T	RT	UT	LT	T	RT		
	4:00 PM	0	1	166	7	0	2	212	6	0	4	0	2	0	4	2		
4:15 PM	0	2	186	3	0	1	244	0	0	5	1	1	0	3	2	2	450	
4:30 PM	0	0	178	4	2	2	180	2	0	6	1	2	0	3	1	2	383	
4:45 PM	0	0	179	7	0	0	219	5	0	2	1	3	0	8	0	3	427	1670
5:00 PM	0	1	188	4	1	4	205	3	0	5	2	1	0	4	0	1	419	1679
5:15 PM	1	3	171	3	0	0	211	1	0	7	1	0	0	6	1	3	408	1637
5:30 PM	0	0	165	3	0	3	209	5	0	2	1	3	0	5	1	2	399	1653
5:45 PM	0	1	136	4	0	1	224	2	0	11	2	3	0	1	0	3	388	1614
Count Total	1	8	1369	35	3	13	1704	24	0	42	9	15	0	34	7	20	3284	--
Peak Hour Total	0	3	731	18	3	7	848	10	0	18	5	7	0	18	3	8	1679	--
PHF	0.97				0.89				0.83				0.66				0.93	--
Heavy Vehicles	0	0	11	0	0	0	26	1	0	1	0	0	0	1	0	1	41	--
HV %	0.0%	0.0%	1.5%	0.0%	0.0%	0.0%	3.1%	10.0%	0.0%	5.6%	0.0%	0.0%	0.0%	5.6%	0.0%	12.5%	2.4%	--

Interval Start Time	Heavy Vehicles				
	EB	WB	NB	SB	Total
4:00 PM	1	4	0	0	5
4:15 PM	1	5	0	1	7
4:30 PM	5	15	1	1	22
4:45 PM	2	4	0	0	6
5:00 PM	3	3	0	0	6
5:15 PM	6	9	1	0	16
5:30 PM	1	8	0	1	10
5:45 PM	1	9	0	0	10
Count Total	20	57	2	3	82
Peak Hour Total	11	27	1	2	41
Peak Hour HV%	1.5%	3.1%	3.3%	6.9%	2.4%

Pedestrians (Leg)				
E	W	N	S	Total
0	0	0	0	0
0	0	0	0	0
0	0	0	0	0
0	0	0	0	0
0	0	0	0	0
0	0	0	0	0
0	0	0	0	0
0	0	0	0	0
0	0	0	0	0
0	0	0	0	0

Bicycles (Leg)				
E	W	N	S	Total
0	0	0	0	0
0	0	0	0	0
0	0	0	0	0
0	0	0	0	0
0	0	0	0	0
0	0	1	0	1
0	0	0	0	0
0	0	0	0	0
0	0	0	0	0
0	0	1	0	1
0	0	0	0	0

Johnson Parkway NE & Sunrise Ridge NE

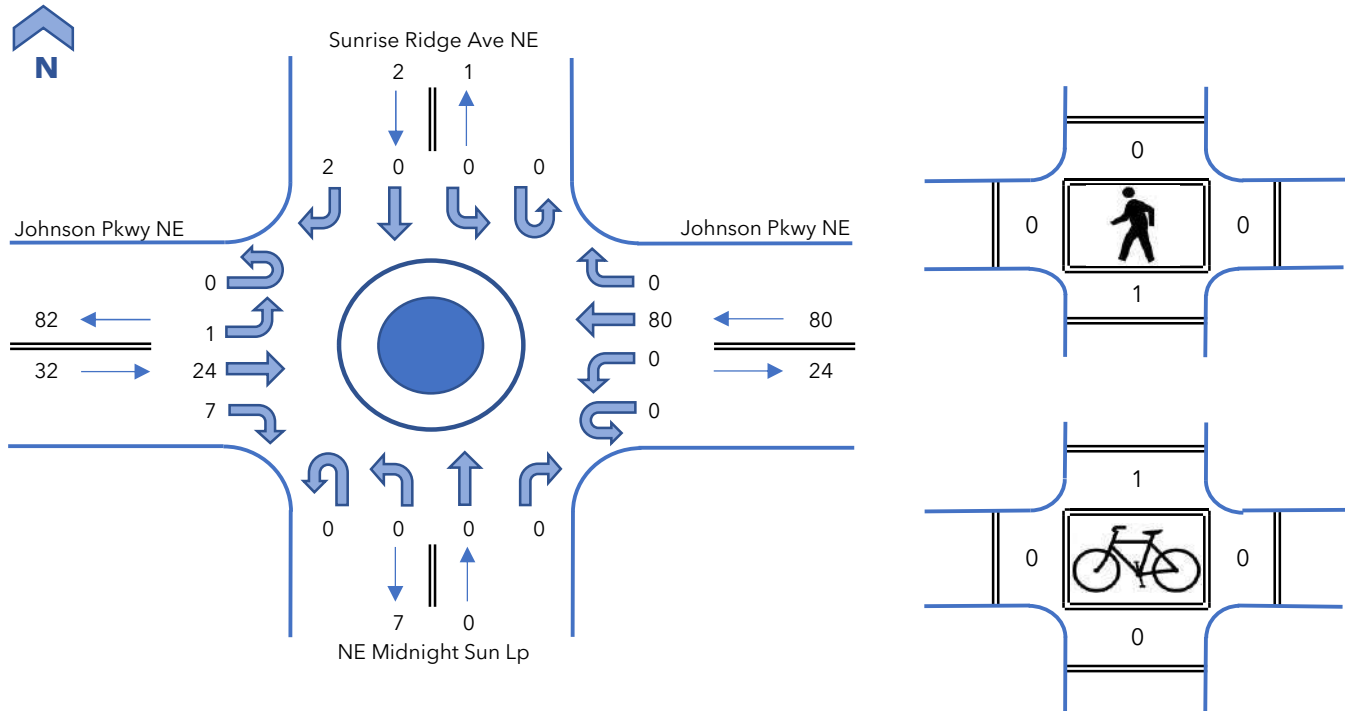

Interval Start Time	Johnson Pkwy NE Eastbound				Johnson Pkwy NE Westbound				NE Midnight Sun Lp Northbound				Sunrise Ridge Ave NE Southbound				15 Minute Totals	Hourly Totals	
	UT	LT	T	RT	UT	LT	T	RT	UT	LT	T	RT	UT	LT	T	RT			
	7:00 AM	0	0	2	0	0	0	12	0	0	1	0	0	0	0	0			0
7:15 AM	0	0	7	4	0	0	19	0	0	0	0	0	0	0	0	0	0	30	
7:30 AM	0	1	9	1	0	0	22	0	0	0	0	0	0	0	0	1	0	34	
7:45 AM	0	0	3	1	0	0	27	0	0	0	0	0	0	0	0	0	0	31	110
8:00 AM	0	0	5	1	0	0	12	0	0	0	0	0	0	0	0	1	0	19	114
8:15 AM	0	0	3	1	0	0	3	0	0	2	0	0	0	0	0	0	0	9	93
8:30 AM	0	1	2	3	0	0	12	0	0	0	0	0	0	0	0	0	0	18	77
8:45 AM	0	0	7	3	0	0	6	0	0	0	0	1	0	0	0	1	0	18	64
Count Total	0	2	38	14	0	0	113	0	0	3	0	1	0	0	0	3	0	174	--
Peak Hour Total	0	1	24	7	0	0	80	0	0	0	0	0	0	0	0	2	0	114	--
PHF	0.73				0.74				#DIV/0!				0.50				0.84	--	
Heavy Vehicles	0	0	1	1	0	0	4	0	0	0	0	0	0	0	0	0	0	6	--
HV %	0.0%	0.0%	4.2%	14.3%	0.0%	0.0%	5.0%	0.0%	0.0%	0.0%	0.0%	0.0%	0.0%	0.0%	0.0%	0.0%	0.0%	5.3%	--

Interval Start Time	Heavy Vehicles				
	EB	WB	NB	SB	Total
7:00 AM	0	0	0	0	0
7:15 AM	0	0	0	0	0
7:30 AM	1	2	0	0	3
7:45 AM	0	2	0	0	2
8:00 AM	1	0	0	0	1
8:15 AM	0	0	1	0	1
8:30 AM	1	2	0	0	3
8:45 AM	2	0	0	0	2
Count Total	5	6	1	0	12
Peak Hour Total	2	4	0	0	6
Peak Hour HV%	6.3%	5.0%	#DIV/0!	0.0%	5.3%

Pedestrians (Leg)				
E	W	N	S	Total
0	0	1	0	1
0	0	0	0	0
0	0	0	0	0
0	0	0	1	1
0	0	0	0	0
0	0	0	0	0
0	0	0	0	0
0	0	0	0	0
0	0	1	1	2
0	0	0	1	1

Bicycles (Leg)				
E	W	N	S	Total
0	0	0	0	0
0	0	0	0	0
0	0	0	0	0
0	0	0	0	0
0	0	1	0	1
0	0	0	0	0
0	0	0	0	0
0	0	0	0	0
0	0	1	0	1
0	0	1	0	1

Johnson Parkway NE & Sunrise Ridge NE

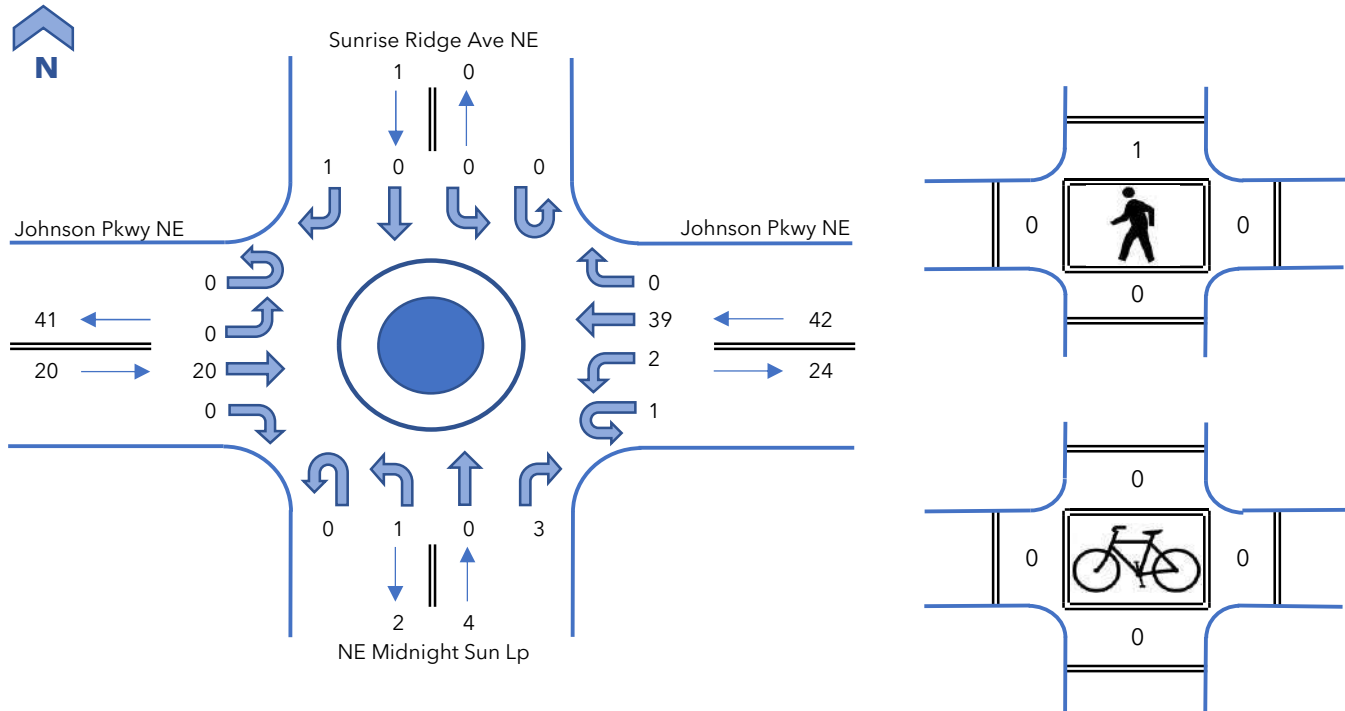

Interval Start Time	Johnson Pkwy NE Eastbound				Johnson Pkwy NE Westbound				NE Midnight Sun Lp Northbound				Sunrise Ridge Ave NE Southbound				15 Minute Totals	Hourly Totals
	UT	LT	T	RT	UT	LT	T	RT	UT	LT	T	RT	UT	LT	T	RT		
	4:00 PM	0	0	6	0	0	1	9	0	0	0	0	0	0	0	0		
4:15 PM	0	0	5	0	0	0	9	0	0	1	0	1	0	0	0	0	16	
4:30 PM	0	0	3	0	1	1	9	0	0	0	0	1	0	0	0	1	16	
4:45 PM	0	0	6	0	0	0	12	0	0	0	0	1	0	0	0	0	19	67
5:00 PM	0	0	4	0	0	0	5	0	0	0	0	0	0	0	0	0	9	60
5:15 PM	0	0	3	1	0	0	10	0	0	1	0	0	0	0	0	1	16	60
5:30 PM	0	0	6	0	0	0	7	0	0	3	0	0	0	0	0	0	16	60
5:45 PM	0	0	2	3	0	0	3	1	0	2	0	0	0	0	0	0	11	52
Count Total	0	0	35	4	1	2	64	1	0	7	0	3	0	0	0	2	119	--
Peak Hour Total	0	0	20	0	1	2	39	0	0	1	0	3	0	0	0	1	67	--
PHF	0.83				0.88				0.50				0.25				0.88	--
Heavy Vehicles	0	0	2	0	0	0	4	0	0	0	0	0	0	0	0	0	6	--
HV %	0.0%	0.0%	10.0%	0.0%	0.0%	0.0%	10.3%	0.0%	0.0%	0.0%	0.0%	0.0%	0.0%	0.0%	0.0%	0.0%	9.0%	--

Interval Start Time	Heavy Vehicles				
	EB	WB	NB	SB	Total
4:00 PM	0	1	0	0	1
4:15 PM	1	2	0	0	3
4:30 PM	1	1	0	0	2
4:45 PM	0	0	0	0	0
5:00 PM	0	0	0	0	0
5:15 PM	2	0	1	0	3
5:30 PM	0	0	1	0	1
5:45 PM	0	0	0	0	0
Count Total	4	4	2	0	10
Peak Hour Total	2	4	0	0	6
Peak Hour HV%	10.0%	9.5%	0.0%	0.0%	9.0%

Interval Start Time	Pedestrians (Leg)				
	E	W	N	S	Total
4:00 PM	0	0	0	0	0
4:15 PM	0	0	0	0	0
4:30 PM	0	0	0	0	0
4:45 PM	0	0	1	0	1
5:00 PM	0	0	0	0	0
5:15 PM	0	0	0	0	0
5:30 PM	0	0	2	0	2
5:45 PM	0	0	0	0	0
Count Total	0	0	3	0	3
Peak Hour Total	0	0	1	0	1

Interval Start Time	Bicycles (Leg)				
	E	W	N	S	Total
4:00 PM	0	0	0	0	0
4:15 PM	0	0	0	0	0
4:30 PM	0	0	0	0	0
4:45 PM	0	0	0	0	0
5:00 PM	0	0	0	0	0
5:15 PM	0	0	0	0	0
5:30 PM	0	0	0	0	0
5:45 PM	0	0	0	0	0
Count Total	0	0	0	0	0
Peak Hour Total	0	0	0	0	0

NE Hostmark Street & Caldart Avenue NE

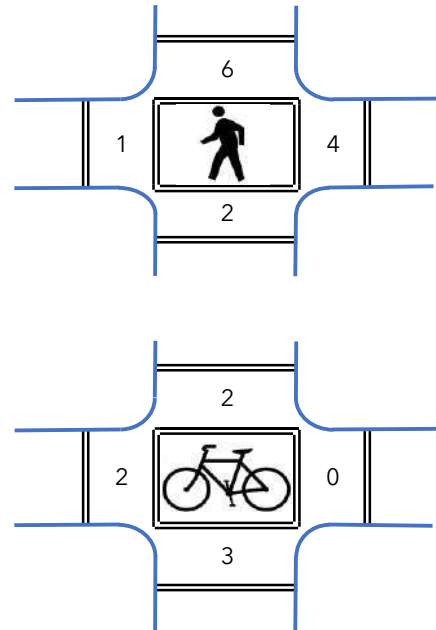
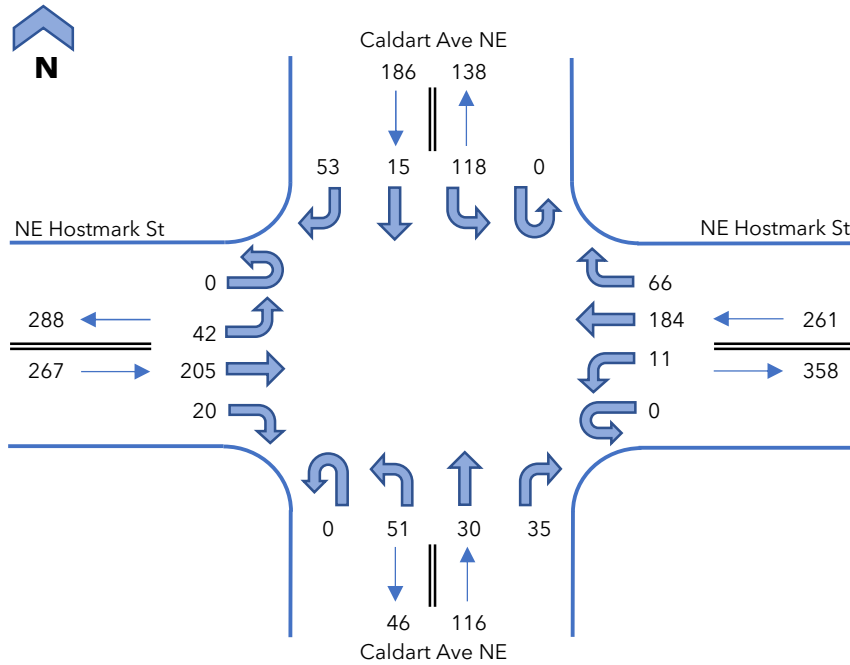

Interval Start Time	NE Hostmark St Eastbound				NE Hostmark St Westbound				Caldart Ave NE Northbound				Caldart Ave NE Southbound				15 Minute Totals	Hourly Totals
	UT	LT	T	RT	UT	LT	T	RT	UT	LT	T	RT	UT	LT	T	RT		
	7:00 AM	0	5	22	5	0	0	26	5	0	13	4	0	0	3	1		
7:15 AM	0	8	57	10	0	1	37	5	0	16	3	1	0	26	1	18	183	
7:30 AM	0	13	70	2	0	6	46	17	0	12	2	21	0	56	5	6	256	
7:45 AM	0	14	53	4	0	3	67	37	0	15	20	13	0	32	2	18	278	809
8:00 AM	0	7	25	4	0	1	34	7	0	8	5	0	0	4	7	11	113	830
8:15 AM	0	5	15	4	0	0	23	1	0	23	5	2	0	8	2	11	99	746
8:30 AM	0	4	29	6	0	0	11	4	0	8	4	0	0	9	7	9	91	581
8:45 AM	0	6	14	6	0	1	23	6	0	13	5	3	0	14	9	13	113	416
Count Total	0	62	285	41	0	12	267	82	0	108	48	40	0	152	34	94	1225	--
Peak Hour Total	0	42	205	20	0	11	184	66	0	51	30	35	0	118	15	53	830	--
PHF	0.79				0.61				0.60				0.69				0.75	--
Heavy Vehicles	0	0	12	1	0	0	13	0	0	0	1	2	0	9	0	2	40	--
HV %	0.0%	0.0%	5.9%	5.0%	0.0%	0.0%	7.1%	0.0%	0.0%	0.0%	3.3%	5.7%	0.0%	7.6%	0.0%	3.8%	4.8%	--

Interval Start Time	Heavy Vehicles				
	EB	WB	NB	SB	Total
7:00 AM	2	1	0	0	3
7:15 AM	8	4	1	4	17
7:30 AM	4	4	1	6	15
7:45 AM	0	2	1	1	4
8:00 AM	1	3	0	0	4
8:15 AM	1	2	1	0	4
8:30 AM	2	1	0	1	4
8:45 AM	3	0	0	1	4
Count Total	21	17	4	13	55
Peak Hour Total	13	13	3	11	40
Peak Hour HV%	4.9%	5.0%	2.6%	5.9%	4.8%

Pedestrians (Leg)				
E	W	N	S	Total
0	0	0	1	1
1	0	1	0	2
2	0	1	1	4
1	1	3	1	6
0	0	1	0	1
0	0	0	0	0
2	1	0	3	6
0	0	0	0	0
6	2	6	6	20
4	1	6	2	13

Bicycles (Leg)				
E	W	N	S	Total
0	0	0	0	0
0	2	1	2	5
0	0	0	1	1
0	0	1	0	1
0	0	0	0	0
0	0	0	0	0
0	0	0	0	0
0	0	0	0	0
0	2	2	3	7
0	2	2	3	7

NE Hostmark Street & Caldart Avenue NE

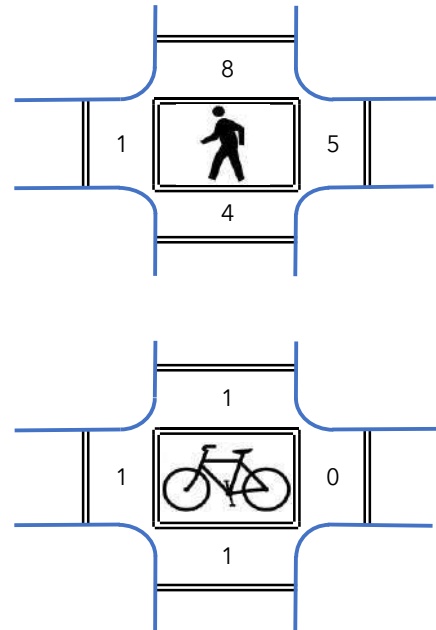
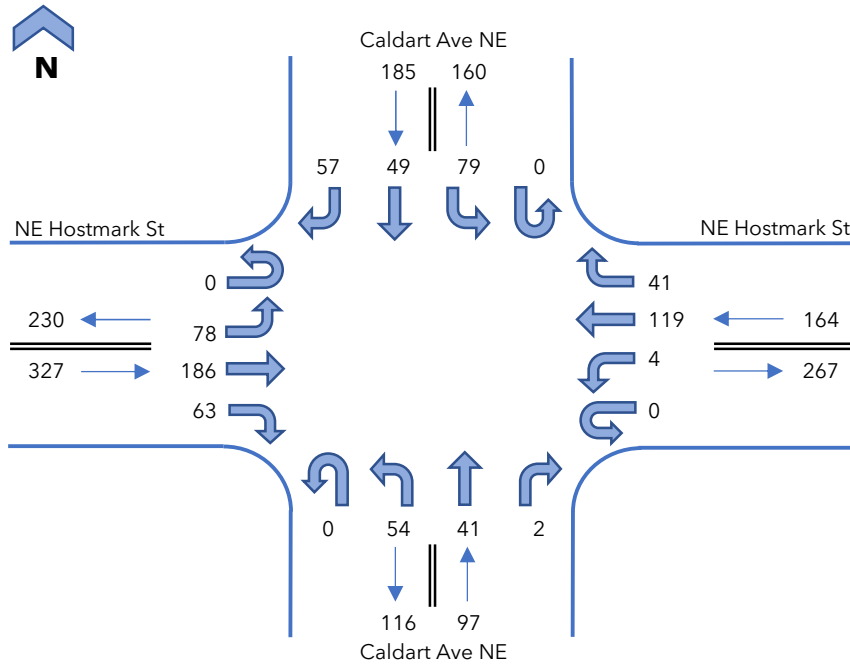

Interval Start Time	NE Hostmark St Eastbound				NE Hostmark St Westbound				Caldart Ave NE Northbound				Caldart Ave NE Southbound				15 Minute Totals	Hourly Totals
	UT	LT	T	RT	UT	LT	T	RT	UT	LT	T	RT	UT	LT	T	RT		
	4:00 PM	0	8	37	21	0	2	48	12	0	21	12	2	0	19	9		
4:15 PM	0	10	35	16	0	0	37	17	0	17	16	1	0	8	7	15	179	
4:30 PM	0	8	54	12	0	0	22	13	0	11	7	0	0	15	8	10	160	
4:45 PM	0	17	64	14	0	1	24	8	0	11	8	1	0	41	19	14	222	766
5:00 PM	0	16	37	22	0	3	40	14	0	15	12	0	0	21	11	14	205	766
5:15 PM	0	21	40	17	0	0	26	10	0	13	13	0	0	6	10	14	170	757
5:30 PM	0	24	45	10	0	0	29	9	0	15	8	1	0	11	9	15	176	773
5:45 PM	0	22	27	7	0	1	18	4	0	7	9	2	0	7	7	13	124	675
Count Total	0	126	339	119	0	7	244	87	0	110	85	7	0	128	80	109	1441	--
Peak Hour Total	0	78	186	63	0	4	119	41	0	54	41	2	0	79	49	57	773	--
PHF	0.86				0.72				0.90				0.63				0.87	--
Heavy Vehicles	0	2	1	0	0	0	0	1	0	0	0	0	0	0	0	2	6	--
HV %	0.0%	2.6%	0.5%	0.0%	0.0%	0.0%	0.0%	2.4%	0.0%	0.0%	0.0%	0.0%	0.0%	0.0%	0.0%	3.5%	0.8%	--

Interval Start Time	Heavy Vehicles				
	EB	WB	NB	SB	Total
4:00 PM	0	1	0	1	2
4:15 PM	0	0	1	1	2
4:30 PM	0	0	0	0	0
4:45 PM	2	1	0	0	3
5:00 PM	0	0	0	1	1
5:15 PM	0	0	0	0	0
5:30 PM	1	0	0	1	2
5:45 PM	2	0	0	0	2
Count Total	5	2	1	4	12
Peak Hour Total	3	1	0	2	6
Peak Hour HV%	0.9%	0.6%	0.0%	1.1%	0.8%

Pedestrians (Leg)				
E	W	N	S	Total
1	0	2	1	4
0	0	5	0	5
3	0	2	0	5
2	1	2	0	5
0	0	2	2	4
1	0	1	2	4
2	0	3	0	5
0	0	0	0	0
9	1	17	5	32
5	1	8	4	18

Bicycles (Leg)				
E	W	N	S	Total
0	0	0	2	2
0	1	0	0	1
1	2	1	1	5
0	0	0	1	1
0	0	0	0	0
0	1	0	0	1
0	0	1	0	1
0	0	0	0	0
1	4	2	4	11
0	1	1	1	3

THE PINNACLE AT LIBERTY BAY TRAFFIC IMPACT ANALYSIS

*APPENDIX
ITE Sheets*



Single-Family Detached Housing (210)

Vehicle Trip Ends vs: Dwelling Units
On a: Weekday

Setting/Location: General Urban/Suburban
Number of Studies: 174
Avg. Num. of Dwelling Units: 246
Directional Distribution: 50% entering, 50% exiting

Vehicle Trip Generation per Dwelling Unit

Average Rate	Range of Rates	Standard Deviation
9.43	4.45 - 22.61	2.13

Data Plot and Equation

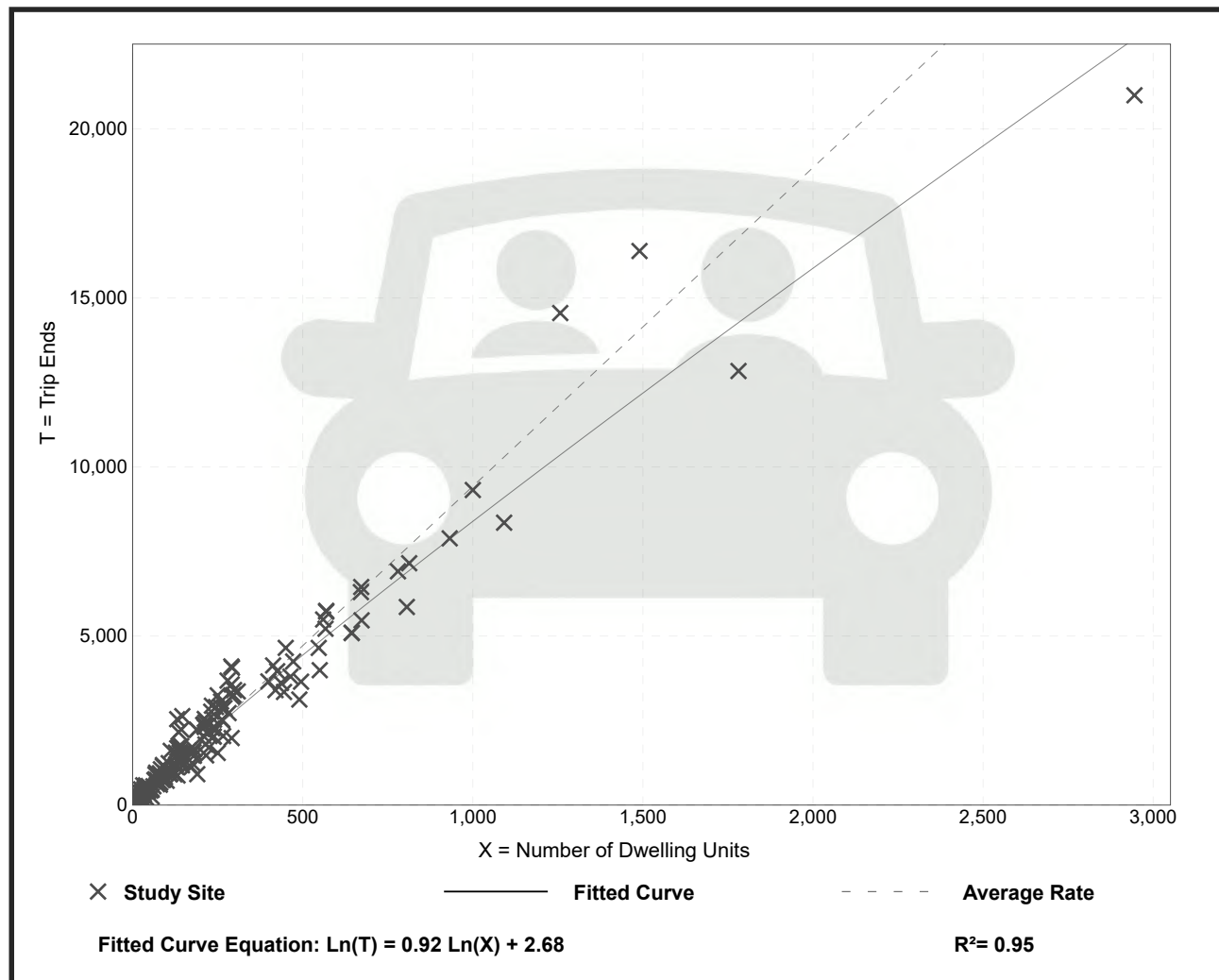

Single-Family Detached Housing (210)

Vehicle Trip Ends vs: Dwelling Units
On a: Weekday,
Peak Hour of Adjacent Street Traffic,
One Hour Between 7 and 9 a.m.
Setting/Location: General Urban/Suburban
 Number of Studies: 192
 Avg. Num. of Dwelling Units: 226
 Directional Distribution: 25% entering, 75% exiting

Vehicle Trip Generation per Dwelling Unit

Average Rate	Range of Rates	Standard Deviation
0.70	0.27 - 2.27	0.24

Data Plot and Equation

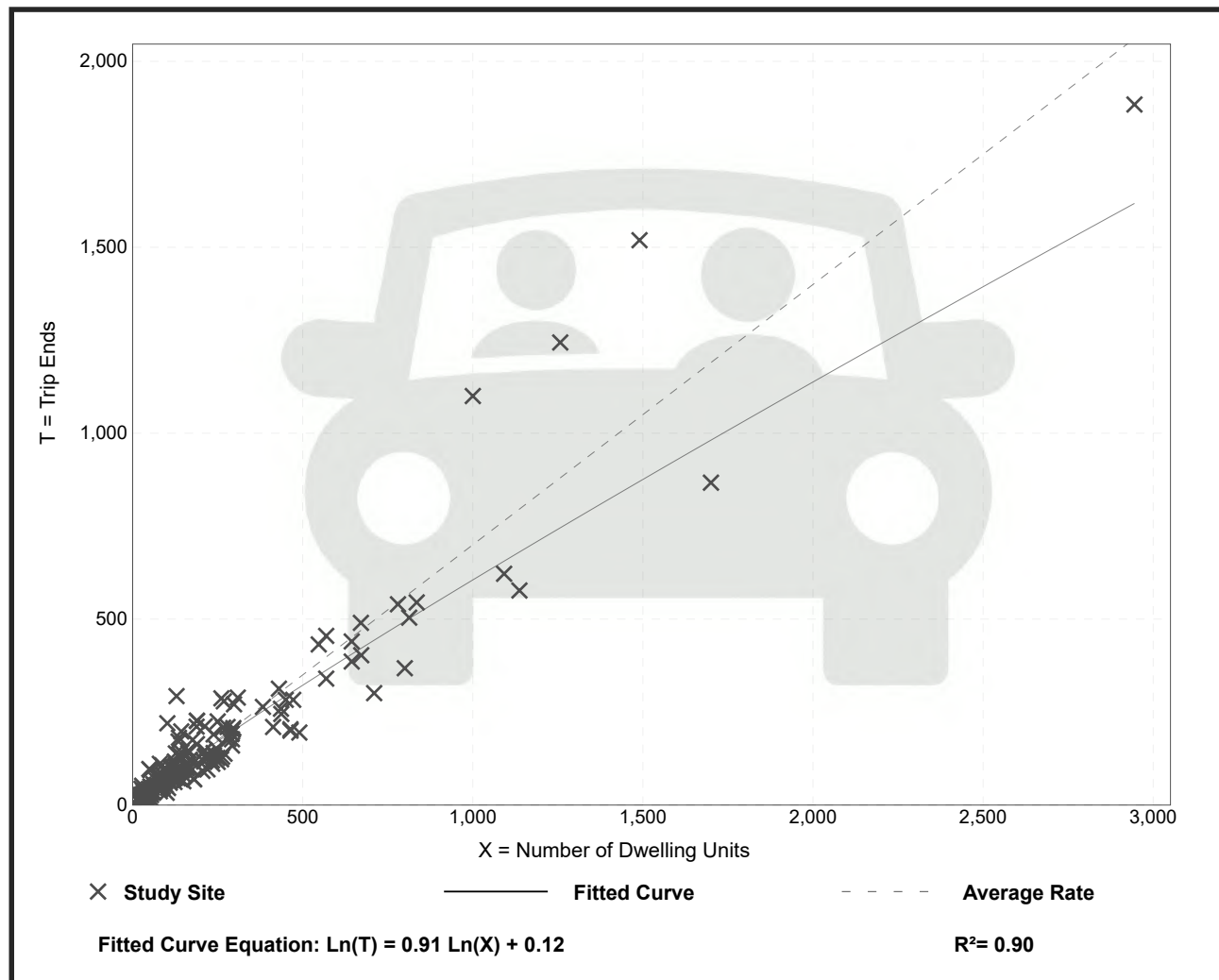

Single-Family Detached Housing (210)

Vehicle Trip Ends vs: Dwelling Units
On a: Weekday,
Peak Hour of Adjacent Street Traffic,
One Hour Between 4 and 6 p.m.

Setting/Location: General Urban/Suburban

Number of Studies: 208
 Avg. Num. of Dwelling Units: 248
 Directional Distribution: 63% entering, 37% exiting

Vehicle Trip Generation per Dwelling Unit

Average Rate	Range of Rates	Standard Deviation
0.94	0.35 - 2.98	0.31

Data Plot and Equation

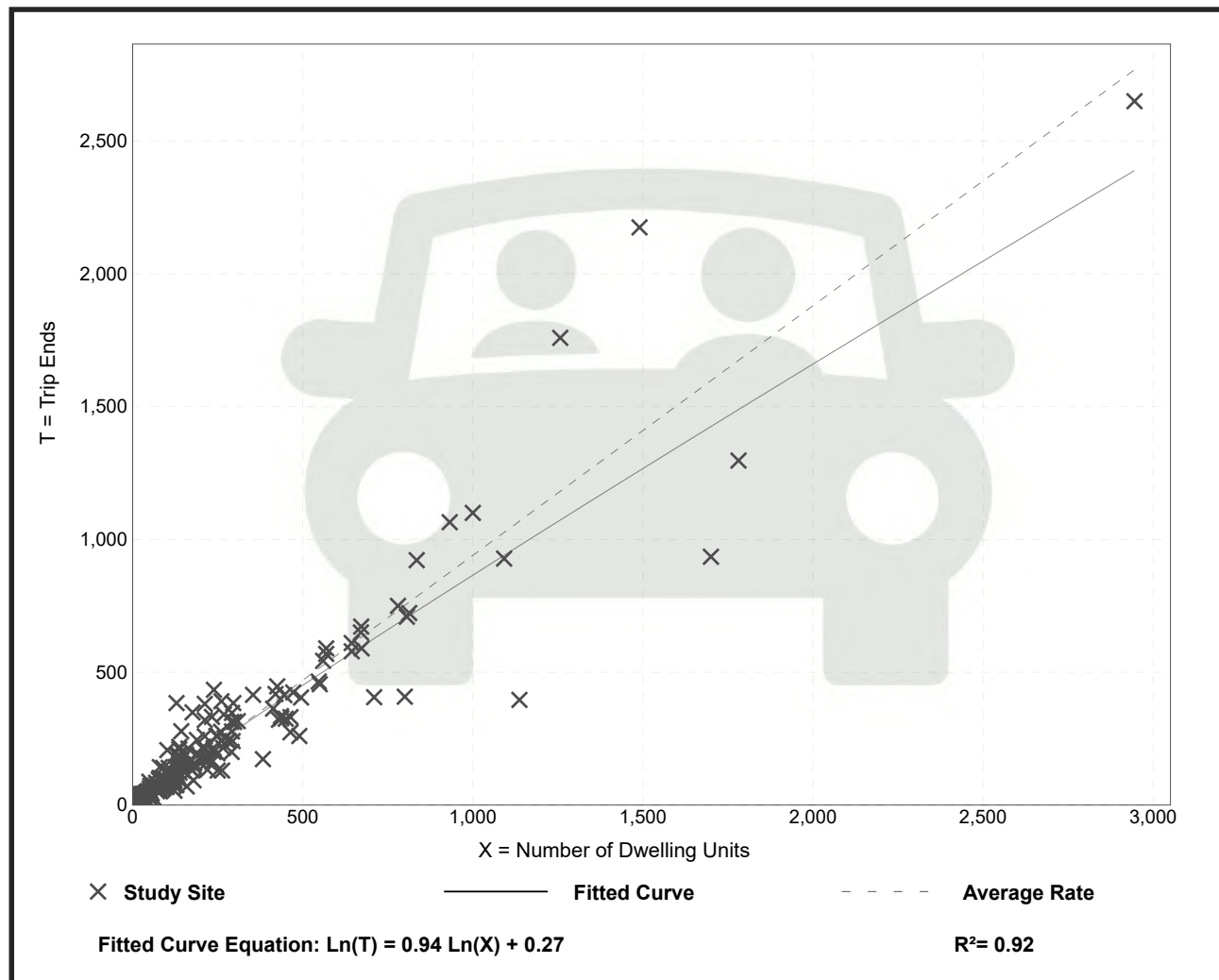

























THE PINNACLE AT LIBERTY BAY TRAFFIC IMPACT ANALYSIS

APPENDIX *Existing Level of Service*



HCM 7th Signalized Intersection Summary
1: SR305 & NE Hostmark St

Existing AM Peak Hour

												
Movement	EBL	EBT	EBR	WBL	WBT	WBR	NBL	NBT	NBR	SBL	SBT	SBR
Lane Configurations												
Traffic Volume (veh/h)	33	94	57	46	75	131	40	469	18	182	847	18
Future Volume (veh/h)	33	94	57	46	75	131	40	469	18	182	847	18
Initial Q (Qb), veh	0	0	0	0	0	0	0	0	0	0	0	0
Lane Width Adj.	1.00	1.00	1.00	1.00	1.00	1.00	1.00	1.00	1.00	1.00	1.00	1.00
Ped-Bike Adj(A_pbT)	0.98		0.97	0.99		0.98	1.00		0.98	1.00		0.99
Parking Bus, Adj	1.00	1.00	1.00	1.00	1.00	1.00	1.00	1.00	1.00	1.00	1.00	1.00
Work Zone On Approach		No			No			No			No	
Adj Sat Flow, veh/h/ln	1716	1730	1744	1744	1744	1716	1730	1716	1716	1730	1716	1646
Adj Flow Rate, veh/h	36	102	62	50	82	77	43	510	20	198	921	20
Peak Hour Factor	0.92	0.92	0.92	0.92	0.92	0.92	0.92	0.92	0.92	0.92	0.92	0.92
Percent Heavy Veh, %	6	5	4	4	4	6	5	6	6	5	6	11
Cap, veh/h	166	164	136	158	183	149	48	576	23	826	1939	42
Arrive On Green	0.02	0.09	0.09	0.03	0.10	0.10	0.03	0.21	0.21	0.50	0.68	0.68
Sat Flow, veh/h	1634	1730	1440	1661	1744	1421	1647	2802	110	1647	2860	62
Grp Volume(v), veh/h	36	102	62	50	82	77	43	221	309	198	392	549
Grp Sat Flow(s),veh/h/ln	1634	1730	1440	1661	1744	1421	1647	1218	1693	1647	1218	1704
Q Serve(g_s), s	2.4	6.8	4.9	3.3	5.3	2.2	3.1	21.2	21.2	8.2	18.3	18.3
Cycle Q Clear(g_c), s	2.4	6.8	4.9	3.3	5.3	2.2	3.1	21.2	21.2	8.2	18.3	18.3
Prop In Lane	1.00		1.00	1.00		1.00	1.00		0.06	1.00		0.04
Lane Grp Cap(c), veh/h	166	164	136	158	183	149	48	250	348	826	826	1156
V/C Ratio(X)	0.22	0.62	0.46	0.32	0.45	0.52	0.90	0.88	0.89	0.24	0.47	0.47
Avail Cap(c_a), veh/h	343	332	276	321	334	272	316	437	607	826	826	1156
HCM Platoon Ratio	1.00	1.00	1.00	1.00	1.00	1.00	1.00	1.00	1.00	1.00	1.00	1.00
Upstream Filter(I)	1.00	1.00	1.00	1.00	1.00	1.00	1.00	1.00	1.00	1.00	1.00	1.00
Uniform Delay (d), s/veh	48.0	52.3	51.4	47.4	50.5	6.5	58.1	46.3	46.3	17.0	9.2	9.2
Incr Delay (d2), s/veh	0.6	3.9	2.4	1.1	1.7	2.8	40.1	33.4	26.5	0.1	2.0	1.4
Initial Q Delay(d3), s/veh	0.0	0.0	0.0	0.0	0.0	0.0	0.0	0.0	0.0	0.0	0.0	0.0
%ile BackOfQ(95%),veh/ln	1.8	5.6	3.3	2.5	4.3	4.0	3.3	13.4	16.8	5.4	8.3	10.6
Unsig. Movement Delay, s/veh												
LnGrp Delay(d), s/veh	48.6	56.1	53.8	48.6	52.2	9.2	98.2	79.6	72.8	17.1	11.1	10.6
LnGrp LOS	D	E	D	D	D	A	F	E	E	B	B	B
Approach Vol, veh/h		200			209			573			1139	
Approach Delay, s/veh		54.0			35.5			77.4			11.9	
Approach LOS		D			D			E			B	
Timer - Assigned Phs	1	2	3	4	5	6	7	8				
Phs Duration (G+Y+Rc), s	65.2	29.7	8.8	16.3	8.5	86.4	7.6	17.6				
Change Period (Y+Rc), s	4.5	4.5	4.5	4.5	4.5	4.5	4.5	4.5				
Max Green Setting (Gmax), s	18.9	43.5	16.1	23.5	23.5	38.9	16.1	23.5				
Max Q Clear Time (g_c+I1), s	10.2	23.2	5.3	8.8	5.1	20.3	4.4	7.3				
Green Ext Time (p_c), s	0.4	1.9	0.1	0.5	0.1	3.8	0.0	0.5				
Intersection Summary												
HCM 7th Control Delay, s/veh			35.9									
HCM 7th LOS			D									

Intersection						
Int Delay, s/veh	0.1					
Movement	EBL	EBT	WBT	WBR	SBL	SBR
Lane Configurations	↖	↗	↗	↖	↖	↖
Traffic Vol, veh/h	0	928	493	1	2	3
Future Vol, veh/h	0	928	493	1	2	3
Conflicting Peds, #/hr	4	0	0	4	4	4
Sign Control	Free	Free	Free	Free	Stop	Stop
RT Channelized	-	None	-	None	-	None
Storage Length	105	-	-	55	60	0
Veh in Median Storage, #	-	0	0	-	0	-
Grade, %	-	0	0	-	0	-
Peak Hour Factor	93	93	93	93	93	93
Heavy Vehicles, %	1	8	6	1	1	1
Mvmt Flow	0	998	530	1	2	3

Major/Minor	Major1	Major2	Minor2		
Conflicting Flow All	535	0	-	0	1536 538
Stage 1	-	-	-	-	534 -
Stage 2	-	-	-	-	1002 -
Critical Hdwy	4.11	-	-	-	6.41 6.21
Critical Hdwy Stg 1	-	-	-	-	5.41 -
Critical Hdwy Stg 2	-	-	-	-	5.41 -
Follow-up Hdwy	2.209	-	-	-	3.509 3.309
Pot Cap-1 Maneuver	1038	-	-	-	128 545
Stage 1	-	-	-	-	590 -
Stage 2	-	-	-	-	357 -
Platoon blocked, %		-	-	-	
Mov Cap-1 Maneuver	1034	-	-	-	128 541
Mov Cap-2 Maneuver	-	-	-	-	128 -
Stage 1	-	-	-	-	588 -
Stage 2	-	-	-	-	355 -

Approach	EB	WB	SB
HCM Ctrl Dly, s/v	0	0	20.49
HCM LOS			C

Minor Lane/Major Mvmt	EBL	EBT	WBT	WBR	SBLn1	SBLn2
Capacity (veh/h)	1034	-	-	-	128	541
HCM Lane V/C Ratio	-	-	-	-	0.017	0.006
HCM Ctrl Dly (s/v)	0	-	-	-	33.7	11.7
HCM Lane LOS	A	-	-	-	D	B
HCM 95th %tile Q(veh)	0	-	-	-	0.1	0

MOVEMENT SUMMARY

 Site: [99] SR 305 & Johnson Rd (Existing AM Peak Hour)
Output produced by SIDRA INTERSECTION Version: 10.0.5.217

New Site
Site Category: (None)
Roundabout
Site Scenario: 1 | Local Volumes

Vehicle Movement Performance															
Mov ID	Turn	Mov Class	Demand Flows		Arrival Flows		Deg. Satn	Aver. Delay	Level of Service	95% Back Of Queue		Prop. Qued	Eff. Stop of Cycles	Number of Cycles to Depart	Aver. Speed
			[Total HV]	[Total HV]	[Total HV]	[Total HV]	v/c	sec		[Veh.]	[Dist]		Rate		mph
			veh/h	%	veh/h	%				veh	ft				
South: Johnson Way															
3u	U	All MCs	1	1.0	1	1.0	0.042	15.8	LOS B	0.2	4.4	0.63	0.77	0.63	30.8
3	L2	All MCs	16	1.0	16	1.0	0.042	12.4	LOS B	0.2	4.4	0.63	0.77	0.63	32.5
8	T1	All MCs	6	1.0	6	1.0	0.042	6.7	LOS A	0.2	4.4	0.63	0.77	0.63	30.0
18	R2	All MCs	3	1.0	3	1.0	0.042	11.4	LOS B	0.2	4.4	0.63	0.77	0.63	32.9
Approach			27	1.0	27	1.0	0.042	11.0	LOS B	0.2	4.4	0.63	0.77	0.63	31.8
East: SR 305															
1u	U	All MCs	1	1.0	1	1.0	0.251	12.0	LOS B	1.5	40.6	0.16	0.46	0.16	37.8
1	L2	All MCs	5	1.0	5	1.0	0.251	11.4	LOS B	1.5	40.6	0.16	0.46	0.16	35.8
6	T1	All MCs	502	6.0	502	6.0	0.251	6.0	LOS A	1.5	40.6	0.16	0.46	0.16	40.8
16	R2	All MCs	11	1.0	11	1.0	0.114	5.8	LOS A	0.6	15.7	0.15	0.46	0.15	36.2
Approach			519	5.8	519	5.8	0.251	6.1	LOS A	1.5	40.6	0.16	0.46	0.16	40.7
North: Johnson Rd															
7u	U	All MCs	1	1.0	1	1.0	0.095	13.7	LOS B	0.3	8.8	0.45	0.70	0.45	31.0
7	L2	All MCs	68	3.0	68	3.0	0.095	10.4	LOS B	0.3	8.8	0.45	0.70	0.45	32.7
4	T1	All MCs	2	1.0	2	1.0	0.095	4.7	LOS A	0.3	8.8	0.45	0.70	0.45	30.3
14	R2	All MCs	12	1.0	12	1.0	0.095	6.0	LOS A	0.3	8.8	0.45	0.70	0.45	33.3
Approach			83	2.6	83	2.6	0.095	9.7	LOS A	0.3	8.8	0.45	0.70	0.45	32.7
West: SR 305															
5u	U	All MCs	1	1.0	1	1.0	0.515	12.3	LOS B	4.3	113.5	0.34	0.47	0.34	37.1
5	L2	All MCs	6	17.0	6	17.0	0.515	12.2	LOS B	4.3	113.5	0.34	0.47	0.34	34.7
2	T1	All MCs	974	8.0	974	8.0	0.515	7.2	LOS A	4.3	113.5	0.33	0.47	0.33	39.8
12	R2	All MCs	18	12.0	18	12.0	0.234	6.3	LOS A	1.4	36.2	0.28	0.47	0.28	35.7
Approach			1000	8.1	1000	8.1	0.515	7.3	LOS A	4.3	113.5	0.33	0.47	0.33	39.7
All Vehicles			1629	7.0	1629	7.0	0.515	7.1	LOS A	4.3	113.5	0.28	0.48	0.28	39.4

Site Level of Service (LOS) Method: Delay & Degree of Saturation (SIDRA). Site LOS Method is specified in the Parameter Settings dialog (Options tab).

Roundabout LOS Method: Same as Signalised Intersections.

Vehicle movement LOS values are based on average delay and v/c ratio (degree of saturation) per movement.

Intersection and Approach LOS values are based on average delay for all movements (v/c not used).

Roundabout Capacity Model: SIDRA HCM.

Delay Model: SIDRA Standard (Control Delay: Geometric Delay is included).

Queue Model: SIDRA queue estimation methods are used for Back of Queue and Queue at Start of Gap.

Gap-Acceptance Capacity Formula: SIDRA Standard (Akçelik M3D).

HV (%) values are calculated for All Movement Classes of All Heavy Vehicle Model Designation.

Arrival Flows used in performance calculations are adjusted to include any Initial Queued Demand and Upstream Capacity Constraint effects.

SITE LAYOUT

 Site: [99] SR 305 & Johnson Rd (Existing AM Peak Hour)

New Site

Site Category: (None)

Roundabout

Site Scenario: 1 | Local Volumes

Layout pictures are schematic functional drawings reflecting input data. They are not design drawings.

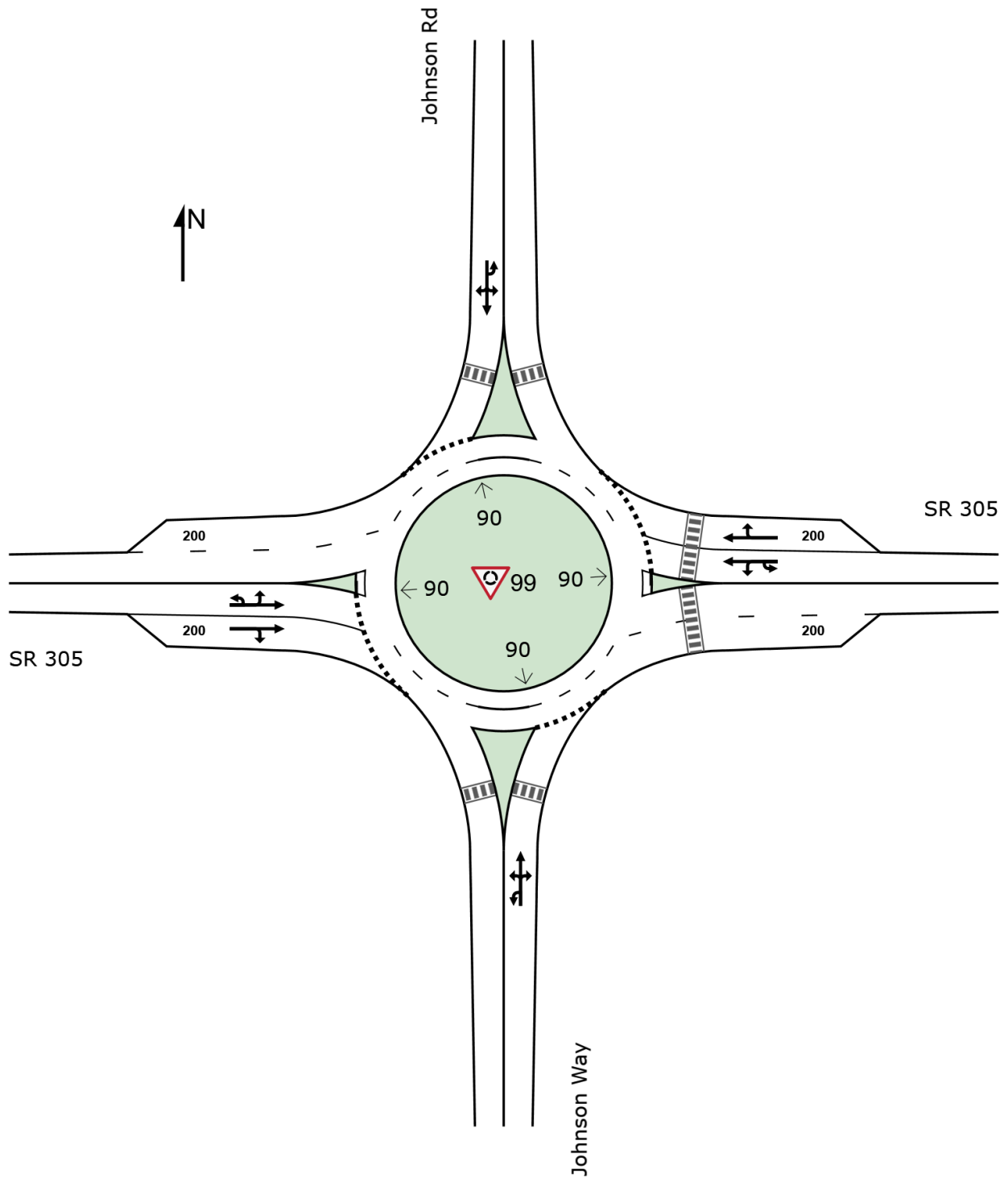

MOVEMENT SUMMARY

 **Site: [1] Johnson & Sunrise Ridge - Existing AM (Folder1)**
 Output produced by SIDRA INTERSECTION Version: 10.0.5.217

New Site
 Site Category: (None)
 Roundabout
Site Scenario: 1 | Local Volumes

Vehicle Movement Performance															
Mov ID	Turn	Mov Class	Demand Flows		Arrival Flows		Deg. Satn	Aver. Delay	Level of Service	95% Back Of Queue		Prop. Qued	Eff. Stop Rate	Number of Cycles to Depart	Aver. Speed
			[Total HV]	[Total HV]	[Total HV]	[Total HV]	v/c	sec		[Veh.]	[Dist]				mph
			veh/h	%	veh/h	%				veh	ft				
South: NE Midnight Sun Loop															
3u	U	All MCs	1 3.0		1 3.0		0.004	7.1	LOSA	0.0	0.4	0.11	0.45	0.11	23.5
3	L2	All MCs	1 3.0		1 3.0		0.004	5.7	LOSA	0.0	0.4	0.11	0.45	0.11	23.5
8	T1	All MCs	1 3.0		1 3.0		0.004	1.9	LOSA	0.0	0.4	0.11	0.45	0.11	23.7
18	R2	All MCs	1 3.0		1 3.0		0.004	2.2	LOSA	0.0	0.4	0.11	0.45	0.11	23.6
Approach			5 3.0		5 3.0		0.004	4.2	LOSA	0.0	0.4	0.11	0.45	0.11	23.6
East: Johnson Rd NE															
1u	U	All MCs	1 3.0		1 3.0		0.073	10.8	LOS B	0.3	7.8	0.05	0.46	0.05	34.8
1	L2	All MCs	1 3.0		1 3.0		0.073	8.9	LOSA	0.3	7.8	0.05	0.46	0.05	34.8
6	T1	All MCs	95 3.0		95 3.0		0.073	4.8	LOSA	0.3	7.8	0.05	0.46	0.05	35.5
16	R2	All MCs	1 3.0		1 3.0		0.073	4.6	LOSA	0.3	7.8	0.05	0.46	0.05	35.1
Approach			99 3.0		99 3.0		0.073	5.0	LOSA	0.3	7.8	0.05	0.46	0.05	35.4
North: Sunrise Ridge Ave NE															
7u	U	All MCs	1 3.0		1 3.0		0.005	11.2	LOS B	0.0	0.5	0.21	0.56	0.21	33.6
7	L2	All MCs	1 3.0		1 3.0		0.005	9.3	LOSA	0.0	0.5	0.21	0.56	0.21	33.6
4	T1	All MCs	1 3.0		1 3.0		0.005	5.2	LOSA	0.0	0.5	0.21	0.56	0.21	34.2
14	R2	All MCs	2 3.0		2 3.0		0.005	5.0	LOSA	0.0	0.5	0.21	0.56	0.21	33.9
Approach			6 3.0		6 3.0		0.005	7.1	LOSA	0.0	0.5	0.21	0.56	0.21	33.8
West: Johnson Rd NE															
5u	U	All MCs	1 3.0		1 3.0		0.030	10.8	LOS B	0.1	3.2	0.05	0.49	0.05	34.7
5	L2	All MCs	1 3.0		1 3.0		0.030	8.9	LOSA	0.1	3.2	0.05	0.49	0.05	34.7
2	T1	All MCs	29 3.0		29 3.0		0.030	4.8	LOSA	0.1	3.2	0.05	0.49	0.05	35.4
12	R2	All MCs	8 3.0		8 3.0		0.030	4.6	LOSA	0.1	3.2	0.05	0.49	0.05	35.1
Approach			39 3.0		39 3.0		0.030	5.1	LOSA	0.1	3.2	0.05	0.49	0.05	35.3
All Vehicles			149 3.0		149 3.0		0.073	5.1	LOSA	0.3	7.8	0.06	0.47	0.06	34.8

Site Level of Service (LOS) Method: Delay & Degree of Saturation (SIDRA). Site LOS Method is specified in the Parameter Settings dialog (Options tab).

Roundabout LOS Method: Same as Signalised Intersections.

Vehicle movement LOS values are based on average delay and v/c ratio (degree of saturation) per movement.

Intersection and Approach LOS values are based on average delay for all movements (v/c not used).

Roundabout Capacity Model: SIDRA HCM.

Delay Model: SIDRA Standard (Control Delay: Geometric Delay is included).

Queue Model: SIDRA queue estimation methods are used for Back of Queue and Queue at Start of Gap.

Gap-Acceptance Capacity Formula: SIDRA Standard (Akçelik M3D).

HV (%) values are calculated for All Movement Classes of All Heavy Vehicle Model Designation.

Arrival Flows used in performance calculations are adjusted to include any Initial Queued Demand and Upstream Capacity Constraint effects.

SITE LAYOUT

 Site: [1] Johnson & Sunrise Ridge - Existing AM (Folder1)

New Site

Site Category: (None)

Roundabout

Site Scenario: 1 | Local Volumes

Layout pictures are schematic functional drawings reflecting input data. They are not design drawings.

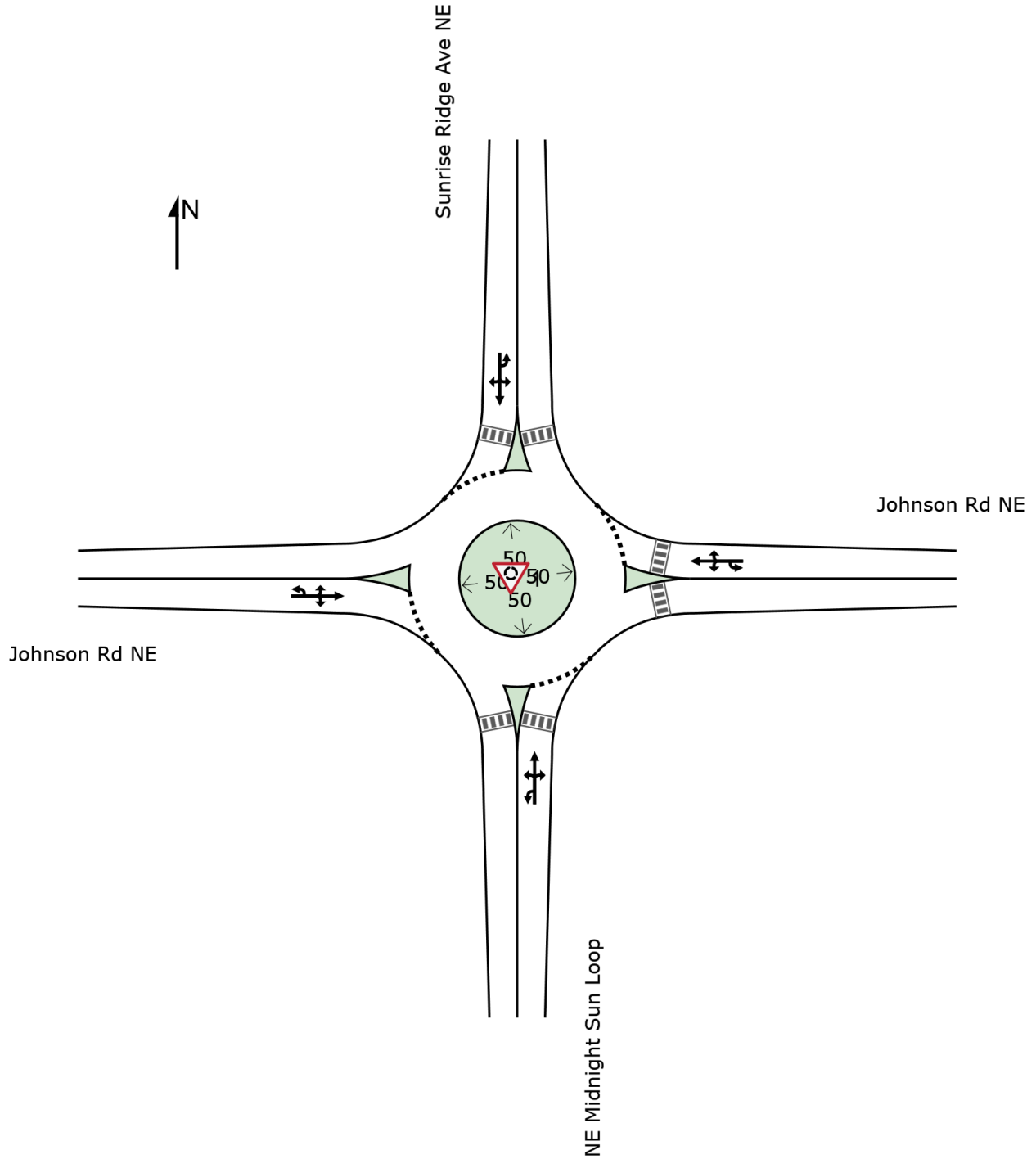

SIDRA INTERSECTION 10.0 | Copyright © 2000-2025 Akcelik and Associates Pty Ltd | sidrasolutions.com

Organisation: HEATH & ASSOCIATES | Licence: PLUS / 1PC | Created: Monday, July 7, 2025 2:13:18 PM

Project: C:\Users\LucasMaulin\Heath and Associates\Office Access - Documents\Project Files\Pinnacle at Liberty Bay - 5576\5-Analysis\Sidra\Johnson & Sunrise Ridge.sipx

Intersection	
Intersection Delay, s/veh	15.1
Intersection LOS	C

Movement	EBL	EBT	EBR	WBL	WBT	WBR	NBL	NBT	NBR	SBL	SBT	SBR
Lane Configurations		↔			↔			↔			↔	↔
Traffic Vol, veh/h	42	205	20	11	184	66	51	30	35	118	15	53
Future Vol, veh/h	42	205	20	11	184	66	51	30	35	118	15	53
Peak Hour Factor	0.75	0.75	0.75	0.75	0.75	0.75	0.87	0.75	0.75	0.75	0.75	0.75
Heavy Vehicles, %	1	6	5	1	7	1	1	3	6	7	1	4
Mvmt Flow	56	273	27	15	245	88	59	40	47	157	20	71
Number of Lanes	0	1	0	0	1	0	0	1	0	0	1	1

Approach	EB	WB	NB	SB
Opposing Approach	WB	EB	SB	NB
Opposing Lanes	1	1	2	1
Conflicting Approach Left	SB	NB	EB	WB
Conflicting Lanes Left	2	1	1	1
Conflicting Approach Right	NB	SB	WB	EB
Conflicting Lanes Right	1	2	1	1
HCM Control Delay, s/veh	16.8	15.9	12.1	13.1
HCM LOS	C	C	B	B

Lane	NBLn1	EBLn1	WBLn1	SBLn1	SBLn2
Vol Left, %	44%	16%	4%	89%	0%
Vol Thru, %	26%	77%	70%	11%	0%
Vol Right, %	30%	7%	25%	0%	100%
Sign Control	Stop	Stop	Stop	Stop	Stop
Traffic Vol by Lane	116	267	261	133	53
LT Vol	51	42	11	118	0
Through Vol	30	205	184	15	0
RT Vol	35	20	66	0	53
Lane Flow Rate	145	356	348	177	71
Geometry Grp	4a	2	2	5	5
Degree of Util (X)	0.267	0.583	0.56	0.366	0.121
Departure Headway (Hd)	6.628	5.897	5.794	7.439	6.165
Convergence, Y/N	Yes	Yes	Yes	Yes	Yes
Cap	540	616	626	484	581
Service Time	4.681	3.911	3.808	5.184	3.91
HCM Lane V/C Ratio	0.269	0.578	0.556	0.366	0.122
HCM Control Delay, s/veh	12.1	16.8	15.9	14.4	9.8
HCM Lane LOS	B	C	C	B	A
HCM 95th-tile Q	1.1	3.8	3.5	1.7	0.4

Intersection						
Int Delay, s/veh	3.9					
Movement	EBT	EBR	WBL	WBT	NBL	NBR
Lane Configurations						
Traffic Vol, veh/h	30	15	5	50	45	20
Future Vol, veh/h	30	15	5	50	45	20
Conflicting Peds, #/hr	0	10	10	0	10	10
Sign Control	Free	Free	Free	Free	Stop	Stop
RT Channelized	-	None	-	None	-	None
Storage Length	-	-	-	-	0	-
Veh in Median Storage, #	0	-	-	0	0	-
Grade, %	0	-	-	0	0	-
Peak Hour Factor	92	92	92	92	92	92
Heavy Vehicles, %	2	2	2	2	2	2
Mvmt Flow	33	16	5	54	49	22

























Major/Minor	Major1	Major2	Minor1		
Conflicting Flow All	0	0	59	0	126 61
Stage 1	-	-	-	-	51 -
Stage 2	-	-	-	-	75 -
Critical Hdwy	-	-	4.12	-	6.42 6.22
Critical Hdwy Stg 1	-	-	-	-	5.42 -
Critical Hdwy Stg 2	-	-	-	-	5.42 -
Follow-up Hdwy	-	-	2.218	-	3.518 3.318
Pot Cap-1 Maneuver	-	-	1545	-	869 1004
Stage 1	-	-	-	-	972 -
Stage 2	-	-	-	-	948 -
Platoon blocked, %	-	-	-	-	-
Mov Cap-1 Maneuver	-	-	1532	-	851 988
Mov Cap-2 Maneuver	-	-	-	-	851 -
Stage 1	-	-	-	-	964 -
Stage 2	-	-	-	-	936 -

Approach	EB	WB	NB
HCM Ctrl Dly, s/v	0	0.67	9.4
HCM LOS			A

Minor Lane/Major Mvmt	NBLn1	EBT	EBR	WBL	WBT
Capacity (veh/h)	889	-	-	164	-
HCM Lane V/C Ratio	0.079	-	-	0.004	-
HCM Ctrl Dly (s/v)	9.4	-	-	7.4	0
HCM Lane LOS	A	-	-	A	A
HCM 95th %tile Q(veh)	0.3	-	-	0	-

HCM 7th Signalized Intersection Summary
 1: SR305 & NE Hostmark St

Existing PM Peak Hour

												
Movement	EBL	EBT	EBR	WBL	WBT	WBR	NBL	NBT	NBR	SBL	SBT	SBR
Lane Configurations												
Traffic Volume (veh/h)	61	152	89	47	111	200	108	788	30	191	628	45
Future Volume (veh/h)	61	152	89	47	111	200	108	788	30	191	628	45
Initial Q (Qb), veh	0	0	0	0	0	0	0	0	0	0	0	0
Lane Width Adj.	1.00	1.00	1.00	1.00	1.00	1.00	1.00	1.00	1.00	1.00	1.00	1.00
Ped-Bike Adj(A_pbT)	0.99		0.96	0.99		0.96	1.00		0.96	1.00		0.97
Parking Bus, Adj	1.00	1.00	1.00	1.00	1.00	1.00	1.00	1.00	1.00	1.00	1.00	1.00
Work Zone On Approach		No			No			No			No	
Adj Sat Flow, veh/h/ln	1702	1758	1786	1786	1786	1786	1772	1744	1786	1786	1772	1744
Adj Flow Rate, veh/h	62	154	90	47	112	56	109	796	30	193	634	45
Peak Hour Factor	0.99	0.99	0.99	0.99	0.99	0.99	0.99	0.99	0.99	0.99	0.99	0.99
Percent Heavy Veh, %	7	3	1	1	1	1	2	4	1	1	2	4
Cap, veh/h	175	201	166	143	183	149	129	863	33	659	1712	121
Arrive On Green	0.04	0.11	0.11	0.03	0.10	0.10	0.08	0.30	0.30	0.39	0.61	0.61
Sat Flow, veh/h	1621	1758	1455	1701	1786	1450	1688	2850	107	1701	2790	198
Grp Volume(v), veh/h	62	154	90	47	112	56	109	346	480	193	286	393
Grp Sat Flow(s),veh/h/ln	1621	1758	1455	1701	1786	1450	1688	1238	1720	1701	1258	1729
Q Serve(g_s), s	4.1	10.2	7.0	3.0	7.2	2.1	7.7	32.4	32.4	9.4	13.6	13.6
Cycle Q Clear(g_c), s	4.1	10.2	7.0	3.0	7.2	2.1	7.7	32.4	32.4	9.4	13.6	13.6
Prop In Lane	1.00		1.00	1.00		1.00	1.00		0.06	1.00		0.11
Lane Grp Cap(c), veh/h	175	201	166	143	183	149	129	375	521	659	772	1062
V/C Ratio(X)	0.35	0.77	0.54	0.33	0.61	0.38	0.85	0.92	0.92	0.29	0.37	0.37
Avail Cap(c_a), veh/h	320	337	279	314	342	278	323	444	616	659	772	1062
HCM Platoon Ratio	1.00	1.00	1.00	1.00	1.00	1.00	1.00	1.00	1.00	1.00	1.00	1.00
Upstream Filter(I)	1.00	1.00	1.00	1.00	1.00	1.00	1.00	1.00	1.00	1.00	1.00	1.00
Uniform Delay (d), s/veh	46.0	51.6	50.2	46.9	51.6	11.8	54.7	40.5	40.5	25.4	11.6	11.6
Incr Delay (d2), s/veh	1.2	6.0	2.7	1.3	3.3	1.6	14.0	30.4	24.3	0.2	1.4	1.0
Initial Q Delay(d3), s/veh	0.0	0.0	0.0	0.0	0.0	0.0	0.0	0.0	0.0	0.0	0.0	0.0
%ile BackOfQ(95%),veh/ln	3.1	8.4	4.8	2.4	6.1	2.9	6.7	18.6	23.5	6.8	6.9	8.9
Unsig. Movement Delay, s/veh												
LnGrp Delay(d), s/veh	47.2	57.6	52.9	48.2	54.9	13.4	68.7	70.9	64.7	25.7	12.9	12.6
LnGrp LOS	D	E	D	D	D	B	E	E	E	C	B	B
Approach Vol, veh/h		306			215			935			872	
Approach Delay, s/veh		54.1			42.6			67.5			15.6	
Approach LOS		D			D			E			B	
Timer - Assigned Phs	1	2	3	4	5	6	7	8				
Phs Duration (G+Y+Rc), s	51.5	41.3	8.5	18.7	14.1	78.7	9.9	17.3				
Change Period (Y+Rc), s	4.5	4.5	4.5	4.5	4.5	4.5	4.5	4.5				
Max Green Setting (Gmax), s	18.9	43.5	16.1	23.5	23.5	38.9	16.1	23.5				
Max Q Clear Time (g_c+I1), s	11.4	34.4	5.0	12.2	9.7	15.6	6.1	9.2				
Green Ext Time (p_c), s	0.4	2.4	0.1	0.7	0.3	2.7	0.1	0.5				
Intersection Summary												
HCM 7th Control Delay, s/veh			44.0									
HCM 7th LOS			D									

Intersection						
Int Delay, s/veh	0.1					
Movement	EBL	EBT	WBT	WBR	SBL	SBR
Lane Configurations	↖	↗	↗	↖	↖	↖
Traffic Vol, veh/h	5	751	870	4	1	3
Future Vol, veh/h	5	751	870	4	1	3
Conflicting Peds, #/hr	1	0	0	1	1	1
Sign Control	Free	Free	Free	Free	Stop	Stop
RT Channelized	-	None	-	None	-	None
Storage Length	105	-	-	55	60	0
Veh in Median Storage, #	-	0	0	-	0	-
Grade, %	-	0	0	-	0	-
Peak Hour Factor	93	93	93	93	93	93
Heavy Vehicles, %	10	2	3	1	10	1
Mvmt Flow	5	808	935	4	1	3

Major/Minor	Major1	Major2	Minor2		
Conflicting Flow All	941	0	-	0	1756 937
Stage 1	-	-	-	-	936 -
Stage 2	-	-	-	-	819 -
Critical Hdwy	4.2	-	-	-	6.5 6.21
Critical Hdwy Stg 1	-	-	-	-	5.5 -
Critical Hdwy Stg 2	-	-	-	-	5.5 -
Follow-up Hdwy	2.29	-	-	-	3.59 3.309
Pot Cap-1 Maneuver	697	-	-	-	89 322
Stage 1	-	-	-	-	369 -
Stage 2	-	-	-	-	420 -
Platoon blocked, %		-	-	-	
Mov Cap-1 Maneuver	696	-	-	-	88 322
Mov Cap-2 Maneuver	-	-	-	-	88 -
Stage 1	-	-	-	-	366 -
Stage 2	-	-	-	-	419 -

Approach	EB	WB	SB
HCM Ctrl Dly, s/v	0.07	0	23.79
HCM LOS			C

Minor Lane/Major Mvmt	EBL	EBT	WBT	WBR	SBLn1	SBLn2
Capacity (veh/h)	696	-	-	-	88	322
HCM Lane V/C Ratio	0.008	-	-	-	0.012	0.01
HCM Ctrl Dly (s/v)	10.2	-	-	-	46.2	16.3
HCM Lane LOS	B	-	-	-	E	C
HCM 95th %tile Q(veh)	0	-	-	-	0	0

MOVEMENT SUMMARY

 Site: [99 (2)] SR 305 & Johnson Rd (Existing PM Peak Hour)
Output produced by SIDRA INTERSECTION Version: 10.0.5.217

New Site
Site Category: (None)
Roundabout
Site Scenario: 1 | Local Volumes

Vehicle Movement Performance															
Mov ID	Turn	Mov Class	Demand Flows		Arrival Flows		Deg. Satn	Aver. Delay	Level of Service	95% Back Of Queue		Prop. Qued	Eff. Stop Rate	Number of Cycles to Depart	Aver. Speed
			[Total HV]	[Total HV]	[Total HV]	[Total HV]	v/c	sec		[Veh.]	[Dist]				mph
			veh/h	%	veh/h	%				veh	ft				
South: Johnson Way															
3u	U	All MCs	1	1.0	1	1.0	0.045	14.5	LOS B	0.2	4.2	0.53	0.72	0.53	31.2
3	L2	All MCs	19	6.0	19	6.0	0.045	11.5	LOS B	0.2	4.2	0.53	0.72	0.53	32.4
8	T1	All MCs	5	1.0	5	1.0	0.045	5.4	LOS A	0.2	4.2	0.53	0.72	0.53	30.4
18	R2	All MCs	8	1.0	8	1.0	0.045	7.5	LOS A	0.2	4.2	0.53	0.72	0.53	33.5
Approach			33	3.9	33	3.9	0.045	9.7	LOS A	0.2	4.2	0.53	0.72	0.53	32.3
East: SR 305															
1u	U	All MCs	3	1.0	3	1.0	0.438	12.0	LOS B	3.4	87.2	0.19	0.45	0.19	37.7
1	L2	All MCs	8	1.0	8	1.0	0.438	11.4	LOS B	3.4	87.2	0.19	0.45	0.19	35.7
6	T1	All MCs	912	3.0	912	3.0	0.438	6.3	LOS A	3.4	87.2	0.18	0.45	0.18	41.2
16	R2	All MCs	11	10.0	11	10.0	0.199	5.9	LOS A	1.1	29.4	0.16	0.46	0.16	36.0
Approach			933	3.1	933	3.1	0.438	6.4	LOS A	3.4	87.2	0.18	0.45	0.18	41.1
North: Johnson Rd															
7u	U	All MCs	1	1.0	1	1.0	0.047	15.0	LOS B	0.2	4.5	0.57	0.75	0.57	30.9
7	L2	All MCs	19	6.0	19	6.0	0.047	12.1	LOS B	0.2	4.5	0.57	0.75	0.57	32.1
4	T1	All MCs	3	1.0	3	1.0	0.047	6.0	LOS A	0.2	4.5	0.57	0.75	0.57	30.2
14	R2	All MCs	9	1.0	9	1.0	0.047	8.6	LOS A	0.2	4.5	0.57	0.75	0.57	33.2
Approach			32	4.0	32	4.0	0.047	10.7	LOS B	0.2	4.5	0.57	0.75	0.57	32.2
West: SR 305															
5u	U	All MCs	1	1.0	1	1.0	0.377	12.0	LOS B	2.6	67.1	0.18	0.45	0.18	37.7
5	L2	All MCs	3	1.0	3	1.0	0.377	11.4	LOS B	2.6	67.1	0.18	0.45	0.18	35.8
2	T1	All MCs	786	2.0	786	2.0	0.377	6.1	LOS A	2.6	67.1	0.18	0.45	0.18	41.5
12	R2	All MCs	19	1.0	19	1.0	0.171	5.8	LOS A	0.9	23.9	0.16	0.46	0.16	36.2
Approach			810	2.0	810	2.0	0.377	6.2	LOS A	2.6	67.1	0.18	0.46	0.18	41.3
All Vehicles			1809	2.6	1809	2.6	0.438	6.4	LOS A	3.4	87.2	0.19	0.46	0.19	40.8

Site Level of Service (LOS) Method: Delay & Degree of Saturation (SIDRA). Site LOS Method is specified in the Parameter Settings dialog (Options tab).

Roundabout LOS Method: Same as Signalised Intersections.

Vehicle movement LOS values are based on average delay and v/c ratio (degree of saturation) per movement.

Intersection and Approach LOS values are based on average delay for all movements (v/c not used).

Roundabout Capacity Model: SIDRA HCM.

Delay Model: SIDRA Standard (Control Delay: Geometric Delay is included).

Queue Model: SIDRA queue estimation methods are used for Back of Queue and Queue at Start of Gap.

Gap-Acceptance Capacity Formula: SIDRA Standard (Akçelik M3D).

HV (%) values are calculated for All Movement Classes of All Heavy Vehicle Model Designation.

Arrival Flows used in performance calculations are adjusted to include any Initial Queued Demand and Upstream Capacity Constraint effects.

SITE LAYOUT

 Site: [99 (2)] SR 305 & Johnson Rd (Existing PM Peak Hour)

New Site

Site Category: (None)

Roundabout

Site Scenario: 1 | Local Volumes

Layout pictures are schematic functional drawings reflecting input data. They are not design drawings.

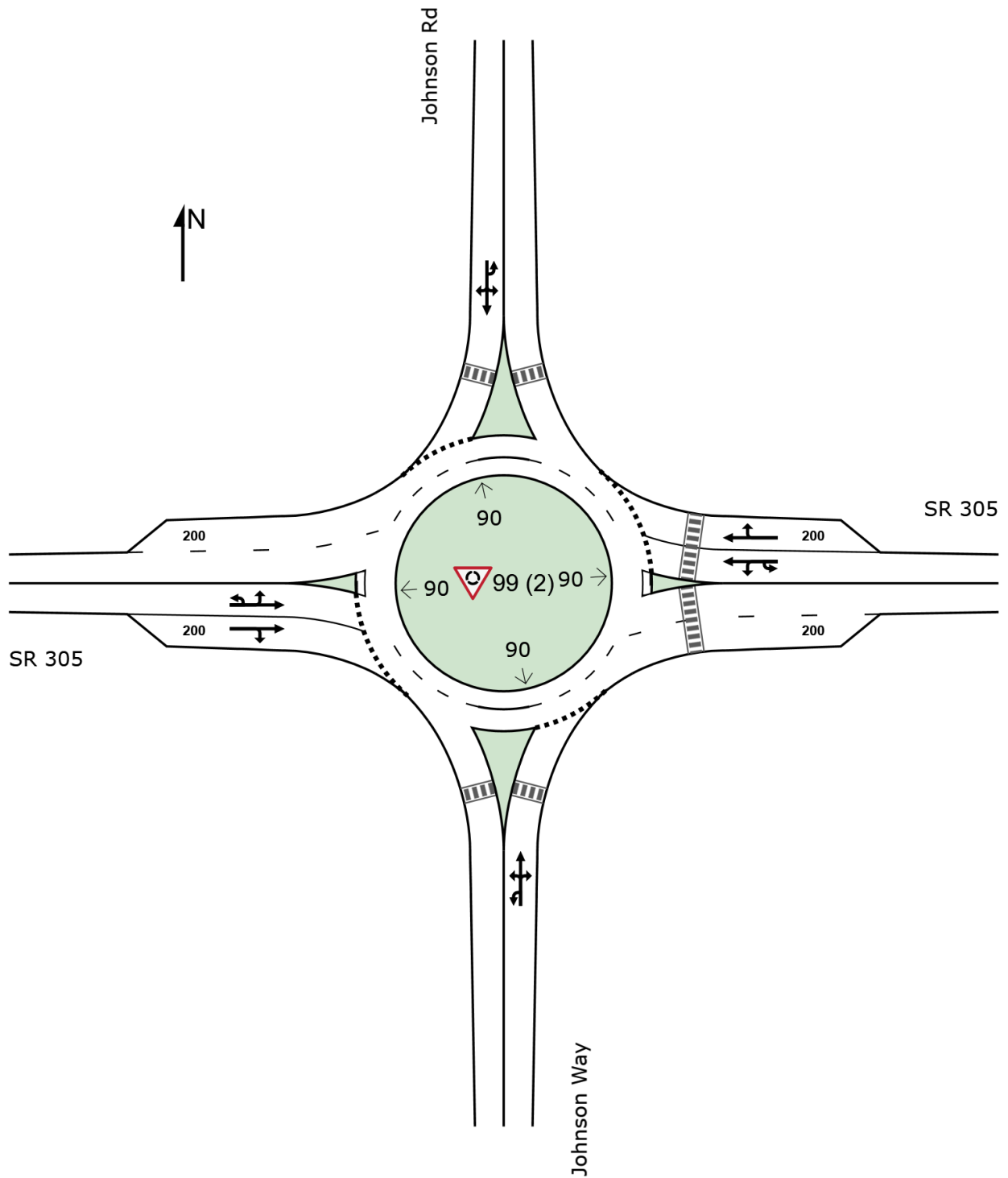

MOVEMENT SUMMARY

 Site: [1 (2)] Johnson & Sunrise Ridge - Existing AP (Folder1)
Output produced by SIDRA INTERSECTION Version: 10.0.5.217

New Site
Site Category: (None)
Roundabout
Site Scenario: 1 | Local Volumes

Vehicle Movement Performance															
Mov ID	Turn	Mov Class	Demand Flows		Arrival Flows		Deg. Satn	Aver. Delay	Level of Service	95% Back Of Queue		Prop. Qued	Eff. Stop Rate	Number of Cycles to Depart	Aver. Speed
			[Total HV]	[Total HV]	[Total HV]	[Total HV]	v/c	sec		[Veh.]	[Dist]				mph
			veh/h	%	veh/h	%				veh	ft				
South: NE Midnight Sun Loop															
3u	U	All MCs	1	3.0	1	3.0	0.005	7.1	LOS A	0.0	0.5	0.10	0.42	0.10	23.7
3	L2	All MCs	1	3.0	1	3.0	0.005	5.7	LOS A	0.0	0.5	0.10	0.42	0.10	23.7
8	T1	All MCs	1	3.0	1	3.0	0.005	1.8	LOS A	0.0	0.5	0.10	0.42	0.10	23.9
18	R2	All MCs	3	3.0	3	3.0	0.005	2.2	LOS A	0.0	0.5	0.10	0.42	0.10	23.8
Approach			7	3.0	7	3.0	0.005	3.5	LOS A	0.0	0.5	0.10	0.42	0.10	23.8
East: Johnson Rd NE															
1u	U	All MCs	1	3.0	1	3.0	0.035	10.8	LOS B	0.1	3.6	0.04	0.47	0.04	34.8
1	L2	All MCs	1	3.0	1	3.0	0.035	8.9	LOS A	0.1	3.6	0.04	0.47	0.04	34.8
6	T1	All MCs	44	3.0	44	3.0	0.035	4.8	LOS A	0.1	3.6	0.04	0.47	0.04	35.4
16	R2	All MCs	1	3.0	1	3.0	0.035	4.6	LOS A	0.1	3.6	0.04	0.47	0.04	35.1
Approach			48	3.0	48	3.0	0.035	5.1	LOS A	0.1	3.6	0.04	0.47	0.04	35.4
North: Sunrise Ridge Ave NE															
7u	U	All MCs	1	3.0	1	3.0	0.004	11.0	LOS B	0.0	0.4	0.14	0.58	0.14	33.5
7	L2	All MCs	1	3.0	1	3.0	0.004	9.1	LOS A	0.0	0.4	0.14	0.58	0.14	33.5
4	T1	All MCs	1	3.0	1	3.0	0.004	5.0	LOS A	0.0	0.4	0.14	0.58	0.14	34.1
14	R2	All MCs	1	3.0	1	3.0	0.004	4.8	LOS A	0.0	0.4	0.14	0.58	0.14	33.8
Approach			5	3.0	5	3.0	0.004	7.5	LOS A	0.0	0.4	0.14	0.58	0.14	33.7
West: Johnson Rd NE															
5u	U	All MCs	1	3.0	1	3.0	0.020	10.8	LOS B	0.1	2.1	0.04	0.49	0.04	34.7
5	L2	All MCs	1	3.0	1	3.0	0.020	8.9	LOS A	0.1	2.1	0.04	0.49	0.04	34.7
2	T1	All MCs	23	3.0	23	3.0	0.020	4.8	LOS A	0.1	2.1	0.04	0.49	0.04	35.3
12	R2	All MCs	1	3.0	1	3.0	0.020	4.6	LOS A	0.1	2.1	0.04	0.49	0.04	35.0
Approach			26	3.0	26	3.0	0.020	5.3	LOS A	0.1	2.1	0.04	0.49	0.04	35.2
All Vehicles			85	3.0	85	3.0	0.035	5.1	LOS A	0.1	3.6	0.05	0.48	0.05	33.9

Site Level of Service (LOS) Method: Delay & Degree of Saturation (SIDRA). Site LOS Method is specified in the Parameter Settings dialog (Options tab).

Roundabout LOS Method: Same as Signalised Intersections.

Vehicle movement LOS values are based on average delay and v/c ratio (degree of saturation) per movement.

Intersection and Approach LOS values are based on average delay for all movements (v/c not used).

Roundabout Capacity Model: SIDRA HCM.

Delay Model: SIDRA Standard (Control Delay: Geometric Delay is included).

Queue Model: SIDRA queue estimation methods are used for Back of Queue and Queue at Start of Gap.

Gap-Acceptance Capacity Formula: SIDRA Standard (Akçelik M3D).

HV (%) values are calculated for All Movement Classes of All Heavy Vehicle Model Designation.

Arrival Flows used in performance calculations are adjusted to include any Initial Queued Demand and Upstream Capacity Constraint effects.

SITE LAYOUT

 Site: [1 (2)] Johnson & Sunrise Ridge - Existing AP (Folder1)

New Site

Site Category: (None)

Roundabout

Site Scenario: 1 | Local Volumes

Layout pictures are schematic functional drawings reflecting input data. They are not design drawings.

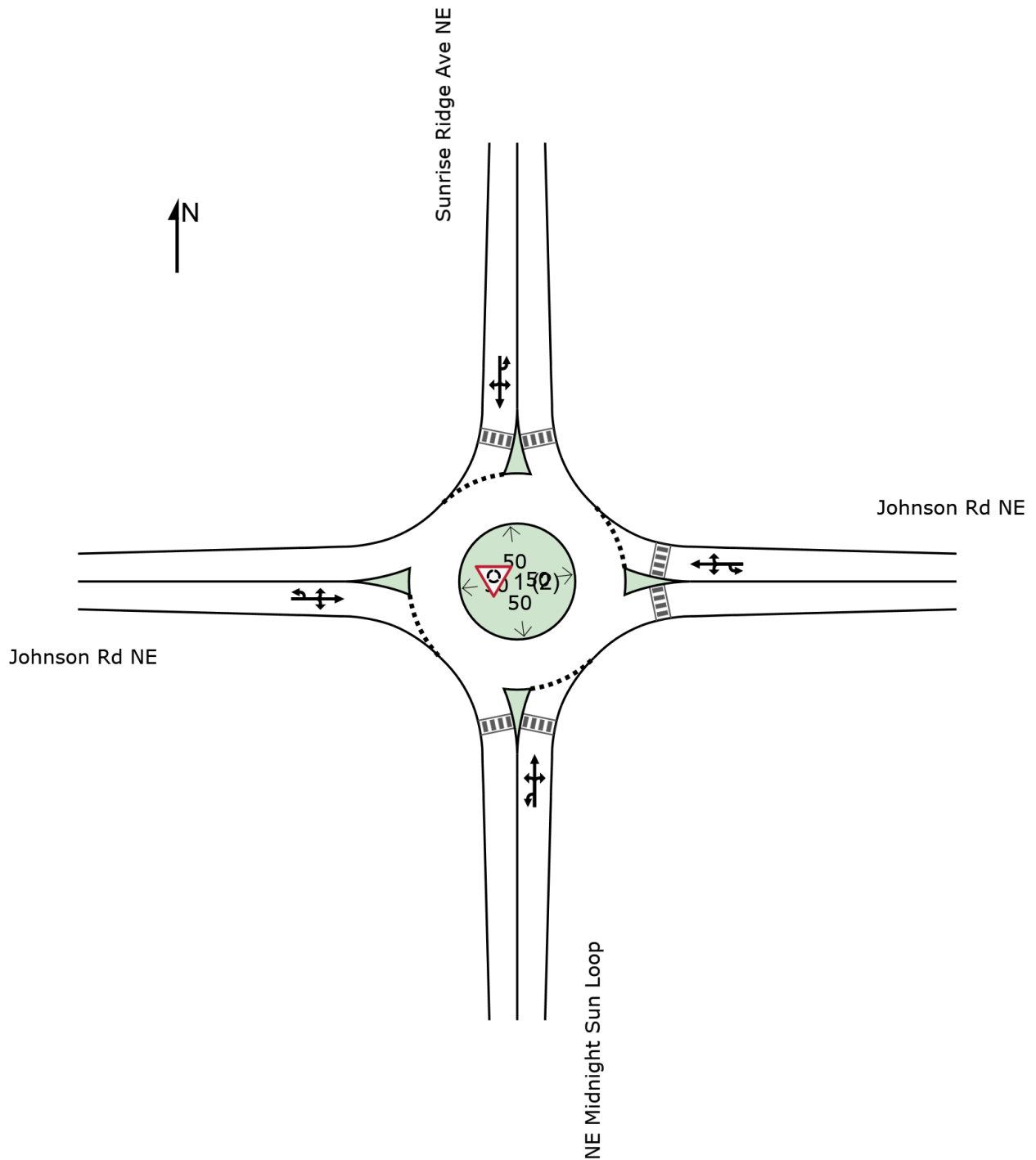

SIDRA INTERSECTION 10.0 | Copyright © 2000-2025 Akcelik and Associates Pty Ltd | sidrasolutions.com

Organisation: HEATH & ASSOCIATES | Licence: PLUS / 1PC | Created: Monday, July 7, 2025 2:12:24 PM

Project: C:\Users\LucasMaulin\Heath and Associates\Office Access - Documents\Project Files\Pinnacle at Liberty Bay - 5576\5-Analysis\Sidra \Johnson & Sunrise Ridge.sipx

Intersection	
Intersection Delay, s/veh	12
Intersection LOS	B

Movement	EBL	EBT	EBR	WBL	WBT	WBR	NBL	NBT	NBR	SBL	SBT	SBR
Lane Configurations		↕			↕			↕			↕	↕
Traffic Vol, veh/h	78	186	63	4	119	41	54	41	2	79	49	57
Future Vol, veh/h	78	186	63	4	119	41	54	41	2	79	49	57
Peak Hour Factor	0.87	0.87	0.87	0.87	0.87	0.87	0.87	0.87	0.87	0.87	0.87	0.87
Heavy Vehicles, %	3	1	1	1	1	2	1	1	1	1	1	4
Mvmt Flow	90	214	72	5	137	47	62	47	2	91	56	66
Number of Lanes	0	1	0	0	1	0	0	1	0	0	1	1

Approach	EB	WB	NB	SB
Opposing Approach	WB	EB	SB	NB
Opposing Lanes	1	1	2	1
Conflicting Approach Left	SB	NB	EB	WB
Conflicting Lanes Left	2	1	1	1
Conflicting Approach Right	NB	SB	WB	EB
Conflicting Lanes Right	1	2	1	1
HCM Control Delay, s/veh	14	10.4	10.5	10.7
HCM LOS	B	B	B	B

Lane	NBLn1	EBLn1	WBLn1	SBLn1	SBLn2
Vol Left, %	56%	24%	2%	62%	0%
Vol Thru, %	42%	57%	73%	38%	0%
Vol Right, %	2%	19%	25%	0%	100%
Sign Control	Stop	Stop	Stop	Stop	Stop
Traffic Vol by Lane	97	327	164	128	57
LT Vol	54	78	4	79	0
Through Vol	41	186	119	49	0
RT Vol	2	63	41	0	57
Lane Flow Rate	111	376	189	147	66
Geometry Grp	4a	2	2	5	5
Degree of Util (X)	0.187	0.537	0.278	0.266	0.1
Departure Headway (Hd)	6.027	5.139	5.312	6.508	5.484
Convergence, Y/N	Yes	Yes	Yes	Yes	Yes
Cap	594	703	675	552	653
Service Time	4.076	3.176	3.356	4.251	3.226
HCM Lane V/C Ratio	0.187	0.535	0.28	0.266	0.101
HCM Control Delay, s/veh	10.5	14	10.4	11.6	8.8
HCM Lane LOS	B	B	B	B	A
HCM 95th-tile Q	0.7	3.2	1.1	1.1	0.3

Intersection						
Int Delay, s/veh	2.8					
Movement	EBT	EBR	WBL	WBT	NBL	NBR
Lane Configurations						
Traffic Vol, veh/h	50	45	20	50	30	15
Future Vol, veh/h	50	45	20	50	30	15
Conflicting Peds, #/hr	0	10	10	0	10	10
Sign Control	Free	Free	Free	Free	Stop	Stop
RT Channelized	-	None	-	None	-	None
Storage Length	-	-	-	-	0	-
Veh in Median Storage, #	0	-	-	0	0	-
Grade, %	0	-	-	0	0	-
Peak Hour Factor	92	92	92	92	92	92
Heavy Vehicles, %	2	2	2	2	2	2
Mvmt Flow	54	49	22	54	33	16

Major/Minor	Major1	Major2	Minor1	Minor2	Minor3
Conflicting Flow All	0	0	113	0	197
Stage 1	-	-	-	-	89
Stage 2	-	-	-	-	108
Critical Hdwy	-	-	4.12	-	6.42
Critical Hdwy Stg 1	-	-	-	-	5.42
Critical Hdwy Stg 2	-	-	-	-	5.42
Follow-up Hdwy	-	-	2.218	-	3.518
Pot Cap-1 Maneuver	-	-	1476	-	792
Stage 1	-	-	-	-	935
Stage 2	-	-	-	-	917
Platoon blocked, %	-	-	-	-	-
Mov Cap-1 Maneuver	-	-	1464	-	767
Mov Cap-2 Maneuver	-	-	-	-	767
Stage 1	-	-	-	-	927
Stage 2	-	-	-	-	895

Approach	EB	WB	NB
HCM Ctrl Dly, s/v	0	2.14	9.68
HCM LOS			A

Minor Lane/Major Mvmt	NBLn1	EBT	EBR	WBL	WBT
Capacity (veh/h)	817	-	-	514	-
HCM Lane V/C Ratio	0.06	-	-	0.015	-
HCM Ctrl Dly (s/v)	9.7	-	-	7.5	0
HCM Lane LOS	A	-	-	A	A
HCM 95th %tile Q(veh)	0.2	-	-	0	-

























THE PINNACLE AT LIBERTY BAY TRAFFIC IMPACT ANALYSIS

APPENDIX
Forecast 2032 Level of Service



HCM 7th Signalized Intersection Summary
1: SR305 & NE Hostmark St

Forecast 2032 AM Peak Hour
Without Project

												
Movement	EBL	EBT	EBR	WBL	WBT	WBR	NBL	NBT	NBR	SBL	SBT	SBR
Lane Configurations												
Traffic Volume (veh/h)	39	108	65	54	89	150	47	491	22	208	881	21
Future Volume (veh/h)	39	108	65	54	89	150	47	491	22	208	881	21
Initial Q (Qb), veh	0	0	0	0	0	0	0	0	0	0	0	0
Lane Width Adj.	1.00	1.00	1.00	1.00	1.00	1.00	1.00	1.00	1.00	1.00	1.00	1.00
Ped-Bike Adj(A_pbT)	0.99		0.98	0.99		0.98	1.00		0.98	1.00		0.99
Parking Bus, Adj	1.00	1.00	1.00	1.00	1.00	1.00	1.00	1.00	1.00	1.00	1.00	1.00
Work Zone On Approach		No			No			No			No	
Adj Sat Flow, veh/h/ln	1716	1730	1744	1744	1744	1716	1730	1716	1716	1730	1716	1646
Adj Flow Rate, veh/h	42	117	71	59	97	98	51	534	24	226	958	23
Peak Hour Factor	0.92	0.92	0.92	0.92	0.92	0.92	0.92	0.92	0.92	0.92	0.92	0.92
Percent Heavy Veh, %	6	5	4	4	4	6	5	6	6	5	6	11
Cap, veh/h	172	175	146	165	198	161	58	601	27	787	1878	45
Arrive On Green	0.03	0.10	0.10	0.04	0.11	0.11	0.04	0.22	0.22	0.48	0.66	0.66
Sat Flow, veh/h	1634	1730	1443	1661	1744	1423	1647	2784	125	1647	2853	68
Grp Volume(v), veh/h	42	117	71	59	97	98	51	233	325	226	409	572
Grp Sat Flow(s),veh/h/ln	1634	1730	1443	1661	1744	1423	1647	1218	1690	1647	1218	1703
Q Serve(g_s), s	2.8	7.8	5.6	3.8	6.3	3.0	3.7	22.3	22.4	10.0	20.7	20.7
Cycle Q Clear(g_c), s	2.8	7.8	5.6	3.8	6.3	3.0	3.7	22.3	22.4	10.0	20.7	20.7
Prop In Lane	1.00		1.00	1.00		1.00	1.00		0.07	1.00		0.04
Lane Grp Cap(c), veh/h	172	175	146	165	198	161	58	263	365	787	802	1121
V/C Ratio(X)	0.24	0.67	0.49	0.36	0.49	0.61	0.88	0.89	0.89	0.29	0.51	0.51
Avail Cap(c_a), veh/h	342	332	277	318	334	273	316	437	606	787	802	1121
HCM Platoon Ratio	1.00	1.00	1.00	1.00	1.00	1.00	1.00	1.00	1.00	1.00	1.00	1.00
Upstream Filter(I)	1.00	1.00	1.00	1.00	1.00	1.00	1.00	1.00	1.00	1.00	1.00	1.00
Uniform Delay (d), s/veh	47.0	52.0	51.0	46.3	49.9	7.2	57.6	45.6	45.7	18.9	10.5	10.5
Incr Delay (d2), s/veh	0.7	4.3	2.5	1.3	1.9	3.6	30.5	32.8	26.1	0.2	2.3	1.7
Initial Q Delay(d3), s/veh	0.0	0.0	0.0	0.0	0.0	0.0	0.0	0.0	0.0	0.0	0.0	0.0
%ile BackOfQ(95%),veh/ln	2.1	6.5	3.8	2.9	5.1	5.1	3.6	13.9	17.5	6.7	9.3	11.9
Unsig. Movement Delay, s/veh												
LnGrp Delay(d), s/veh	47.7	56.3	53.4	47.6	51.8	10.8	88.1	78.4	71.8	19.1	12.8	12.2
LnGrp LOS	D	E	D	D	D	B	F	E	E	B	B	B
Approach Vol, veh/h		230			254			609			1207	
Approach Delay, s/veh		53.8			35.0			75.7			13.7	
Approach LOS		D			D			E			B	
Timer - Assigned Phs	1	2	3	4	5	6	7	8				
Phs Duration (G+Y+Rc), s	62.4	30.9	9.6	17.2	9.2	84.0	8.1	18.6				
Change Period (Y+Rc), s	4.5	4.5	4.5	4.5	4.5	4.5	4.5	4.5				
Max Green Setting (Gmax), s	18.9	43.5	16.1	23.5	23.5	38.9	16.1	23.5				
Max Q Clear Time (g_c+I1), s	12.0	24.4	5.8	9.8	5.7	22.7	4.8	8.3				
Green Ext Time (p_c), s	0.4	2.0	0.1	0.6	0.1	3.8	0.1	0.6				
Intersection Summary												
HCM 7th Control Delay, s/veh			36.5									
HCM 7th LOS			D									

Intersection						
Int Delay, s/veh	0.1					
Movement	EBL	EBT	WBT	WBR	SBL	SBR
Lane Configurations	↖	↗	↗	↖	↖	↖
Traffic Vol, veh/h	0	971	515	1	2	3
Future Vol, veh/h	0	971	515	1	2	3
Conflicting Peds, #/hr	4	0	0	4	4	4
Sign Control	Free	Free	Free	Free	Stop	Stop
RT Channelized	-	None	-	None	-	None
Storage Length	105	-	-	55	60	0
Veh in Median Storage, #	-	0	0	-	0	-
Grade, %	-	0	0	-	0	-
Peak Hour Factor	93	93	93	93	93	93
Heavy Vehicles, %	1	8	6	1	1	1
Mvmt Flow	0	1044	554	1	2	3

Major/Minor	Major1	Major2	Minor2
Conflicting Flow All	559	0	0
Stage 1	-	-	-
Stage 2	-	-	-
Critical Hdwy	4.11	-	-
Critical Hdwy Stg 1	-	-	-
Critical Hdwy Stg 2	-	-	-
Follow-up Hdwy	2.209	-	-
Pot Cap-1 Maneuver	1017	-	-
Stage 1	-	-	-
Stage 2	-	-	-
Platoon blocked, %	-	-	-
Mov Cap-1 Maneuver	1014	-	-
Mov Cap-2 Maneuver	-	-	-
Stage 1	-	-	-
Stage 2	-	-	-

Approach	EB	WB	SB
HCM Ctrl Dly, s/v	0	0	21.83
HCM LOS			C

Minor Lane/Major Mvmt	EBL	EBT	WBT	WBR	SBLn1	SBLn2
Capacity (veh/h)	1014	-	-	-	116	525
HCM Lane V/C Ratio	-	-	-	-	0.019	0.006
HCM Ctrl Dly (s/v)	0	-	-	-	36.7	11.9
HCM Lane LOS	A	-	-	-	E	B
HCM 95th %tile Q(veh)	0	-	-	-	0.1	0

MOVEMENT SUMMARY

 Site: [99 (3)] SR 305 & Johnson Rd - Forecast 2032 AM
Without (Existing AM Peak Hour)

Output produced by SIDRA INTERSECTION Version: 10.0.5.217

New Site
Site Category: (None)
Roundabout
Site Scenario: 1 | Local Volumes

Vehicle Movement Performance															
Mov ID	Turn	Mov Class	Demand Flows		Arrival Flows		Deg. Satn	Aver. Delay	Level of Service	95% Back Of Queue		Prop. Qued	Eff. Stop of Cycles	Number of Cycles to Depart	Aver. Speed
			[Total HV]	[Total HV]	[Total HV]	[Total HV]	v/c	sec		[Veh.]	[Dist]		Rate		mph
			veh/h	%	veh/h	%				veh	ft				
South: Johnson Way															
3u	U	All MCs	1	1.0	1	1.0	0.050	16.3	LOS B	0.2	5.5	0.67	0.79	0.67	30.6
3	L2	All MCs	18	1.0	18	1.0	0.050	12.8	LOS B	0.2	5.5	0.67	0.79	0.67	32.3
8	T1	All MCs	8	1.0	8	1.0	0.050	7.2	LOS A	0.2	5.5	0.67	0.79	0.67	29.8
18	R2	All MCs	3	1.0	3	1.0	0.050	12.8	LOS B	0.2	5.5	0.67	0.79	0.67	32.7
Approach			30	1.0	30	1.0	0.050	11.5	LOS B	0.2	5.5	0.67	0.79	0.67	31.6
East: SR 305															
1u	U	All MCs	1	1.0	1	1.0	0.266	12.0	LOS B	1.7	43.3	0.18	0.46	0.18	37.7
1	L2	All MCs	8	1.0	8	1.0	0.266	11.4	LOS B	1.7	43.3	0.18	0.46	0.18	35.7
6	T1	All MCs	522	6.0	522	6.0	0.266	6.1	LOS A	1.7	43.3	0.18	0.46	0.18	40.7
16	R2	All MCs	16	1.0	16	1.0	0.121	5.8	LOS A	0.6	16.6	0.17	0.47	0.17	36.2
Approach			546	5.8	546	5.8	0.266	6.1	LOS A	1.7	43.3	0.18	0.46	0.18	40.5
North: Johnson Rd															
7u	U	All MCs	1	1.0	1	1.0	0.131	13.9	LOS B	0.5	12.5	0.48	0.70	0.48	31.0
7	L2	All MCs	91	3.0	91	3.0	0.131	10.6	LOS B	0.5	12.5	0.48	0.70	0.48	32.6
4	T1	All MCs	2	1.0	2	1.0	0.131	4.8	LOS A	0.5	12.5	0.48	0.70	0.48	30.3
14	R2	All MCs	17	1.0	17	1.0	0.131	6.2	LOS A	0.5	12.5	0.48	0.70	0.48	33.3
Approach			112	2.6	112	2.6	0.131	9.9	LOS A	0.5	12.5	0.48	0.70	0.48	32.6
West: SR 305															
5u	U	All MCs	1	1.0	1	1.0	0.553	12.5	LOS B	4.8	127.3	0.42	0.48	0.42	36.8
5	L2	All MCs	11	17.0	11	17.0	0.553	12.5	LOS B	4.8	127.3	0.42	0.48	0.42	34.5
2	T1	All MCs	1015	8.0	1015	8.0	0.553	7.7	LOS A	4.8	127.3	0.40	0.48	0.40	39.5
12	R2	All MCs	20	12.0	20	12.0	0.251	6.5	LOS A	1.5	39.3	0.33	0.49	0.33	35.5
Approach			1047	8.2	1047	8.2	0.553	7.7	LOS A	4.8	127.3	0.39	0.48	0.39	39.4
All Vehicles			1735	6.9	1735	6.9	0.553	7.4	LOS A	4.8	127.3	0.34	0.50	0.34	39.0

Site Level of Service (LOS) Method: Delay & Degree of Saturation (SIDRA). Site LOS Method is specified in the Parameter Settings dialog (Options tab).

Roundabout LOS Method: Same as Signalised Intersections.

Vehicle movement LOS values are based on average delay and v/c ratio (degree of saturation) per movement.

Intersection and Approach LOS values are based on average delay for all movements (v/c not used).

Roundabout Capacity Model: SIDRA HCM.

Delay Model: SIDRA Standard (Control Delay: Geometric Delay is included).

Queue Model: SIDRA queue estimation methods are used for Back of Queue and Queue at Start of Gap.

Gap-Acceptance Capacity Formula: SIDRA Standard (Akçelik M3D).

HV (%) values are calculated for All Movement Classes of All Heavy Vehicle Model Designation.

Arrival Flows used in performance calculations are adjusted to include any Initial Queued Demand and Upstream Capacity Constraint effects.

SITE LAYOUT

 Site: [99 (3)] SR 305 & Johnson Rd - Forecast 2032 AM
Without (Existing AM Peak Hour)

New Site
Site Category: (None)
Roundabout
Site Scenario: 1 | Local Volumes

Layout pictures are schematic functional drawings reflecting input data. They are not design drawings.

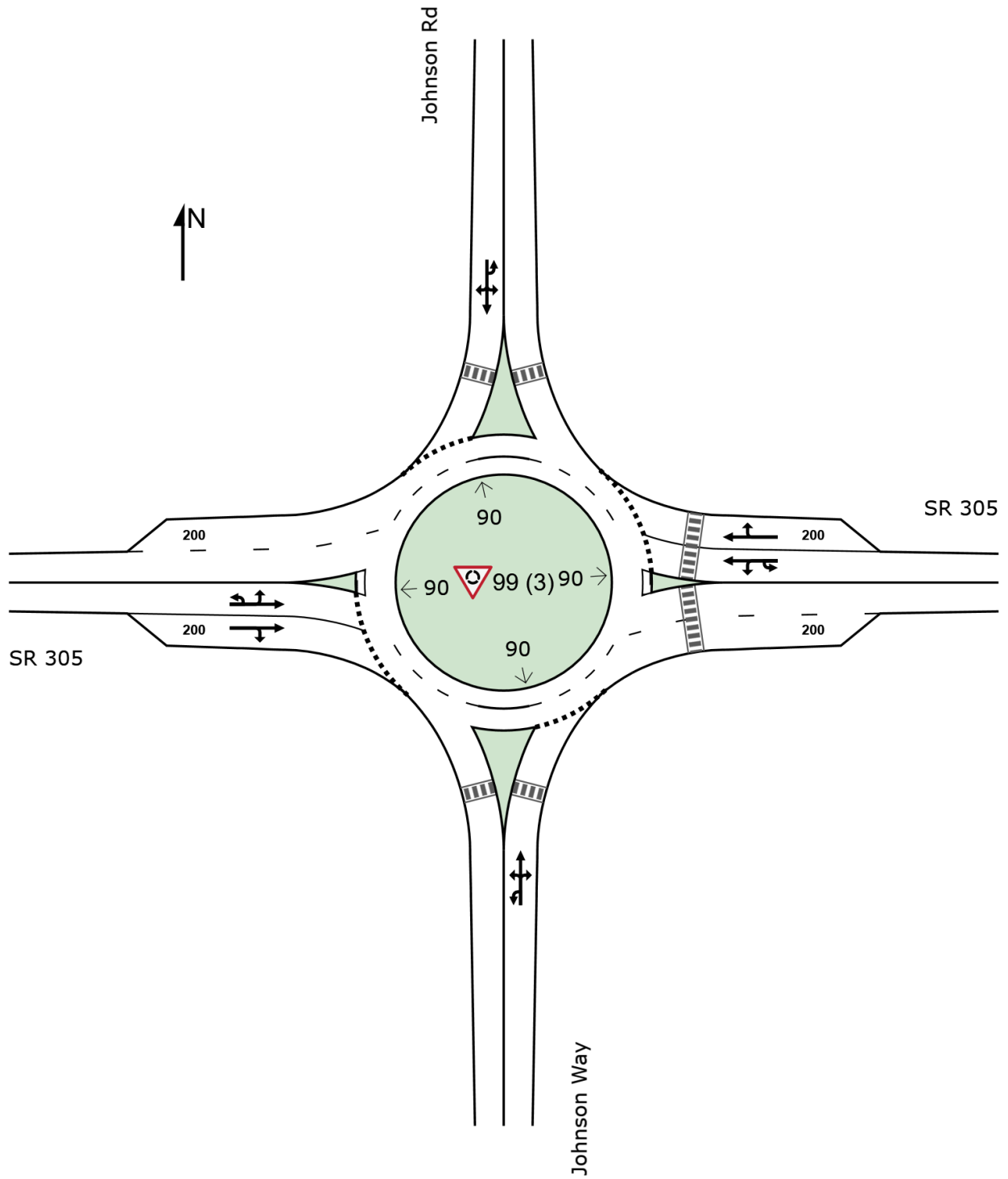

MOVEMENT SUMMARY

 Site: [1 (3)] Johnson & Sunrise Ridge - 2032 AM Without (Folder1)

Output produced by SIDRA INTERSECTION Version: 10.0.5.217

New Site
 Site Category: (None)
 Roundabout
Site Scenario: 1 | Local Volumes

Vehicle Movement Performance															
Mov ID	Turn	Mov Class	Demand Flows		Arrival Flows		Deg. Satn	Aver. Delay	Level of Service	95% Back Of Queue		Prop. Qued	Eff. Stop of Cycles	Number of Cycles to Depart	Aver. Speed
			[Total HV]	[Total HV]	[Total HV]	[Total HV]	v/c	sec		[Veh.]	[Dist]		Rate		mph
			veh/h	%	veh/h	%				veh	ft				
South: NE Midnight Sun Loop															
3u	U	All MCs	1	3.0	1	3.0	0.004	7.2	LOSA	0.0	0.4	0.15	0.45	0.15	23.5
3	L2	All MCs	1	3.0	1	3.0	0.004	5.8	LOSA	0.0	0.4	0.15	0.45	0.15	23.5
8	T1	All MCs	1	3.0	1	3.0	0.004	2.0	LOSA	0.0	0.4	0.15	0.45	0.15	23.7
18	R2	All MCs	1	3.0	1	3.0	0.004	2.3	LOSA	0.0	0.4	0.15	0.45	0.15	23.6
Approach			5	3.0	5	3.0	0.004	4.3	LOSA	0.0	0.4	0.15	0.45	0.15	23.6
East: Johnson Rd NE															
1u	U	All MCs	1	3.0	1	3.0	0.071	10.9	LOS B	0.3	7.5	0.09	0.46	0.09	34.7
1	L2	All MCs	1	3.0	1	3.0	0.071	8.9	LOSA	0.3	7.5	0.09	0.46	0.09	34.7
6	T1	All MCs	87	3.0	87	3.0	0.071	4.9	LOSA	0.3	7.5	0.09	0.46	0.09	35.3
16	R2	All MCs	5	3.0	5	3.0	0.071	4.7	LOSA	0.3	7.5	0.09	0.46	0.09	35.0
Approach			94	3.0	94	3.0	0.071	5.0	LOSA	0.3	7.5	0.09	0.46	0.09	35.3
North: Sunrise Ridge Ave NE															
7u	U	All MCs	1	3.0	1	3.0	0.051	11.2	LOS B	0.2	5.4	0.21	0.56	0.21	34.1
7	L2	All MCs	14	3.0	14	3.0	0.051	9.3	LOSA	0.2	5.4	0.21	0.56	0.21	34.1
4	T1	All MCs	1	3.0	1	3.0	0.051	5.2	LOSA	0.2	5.4	0.21	0.56	0.21	34.7
14	R2	All MCs	43	3.0	43	3.0	0.051	5.0	LOSA	0.2	5.4	0.21	0.56	0.21	34.4
Approach			60	3.0	60	3.0	0.051	6.1	LOSA	0.2	5.4	0.21	0.56	0.21	34.3
West: Johnson Rd NE															
5u	U	All MCs	1	3.0	1	3.0	0.040	10.9	LOS B	0.2	4.3	0.09	0.54	0.09	34.1
5	L2	All MCs	14	3.0	14	3.0	0.040	9.0	LOSA	0.2	4.3	0.09	0.54	0.09	34.1
2	T1	All MCs	26	3.0	26	3.0	0.040	4.9	LOSA	0.2	4.3	0.09	0.54	0.09	34.8
12	R2	All MCs	10	3.0	10	3.0	0.040	4.7	LOSA	0.2	4.3	0.09	0.54	0.09	34.5
Approach			51	3.0	51	3.0	0.040	6.1	LOSA	0.2	4.3	0.09	0.54	0.09	34.5
All Vehicles			210	3.0	210	3.0	0.071	5.6	LOSA	0.3	7.5	0.13	0.51	0.13	34.4

Site Level of Service (LOS) Method: Delay & Degree of Saturation (SIDRA). Site LOS Method is specified in the Parameter Settings dialog (Options tab).

Roundabout LOS Method: Same as Signalised Intersections.

Vehicle movement LOS values are based on average delay and v/c ratio (degree of saturation) per movement.

Intersection and Approach LOS values are based on average delay for all movements (v/c not used).

Roundabout Capacity Model: SIDRA HCM.

Delay Model: SIDRA Standard (Control Delay: Geometric Delay is included).

Queue Model: SIDRA queue estimation methods are used for Back of Queue and Queue at Start of Gap.

Gap-Acceptance Capacity Formula: SIDRA Standard (Akçelik M3D).

HV (%) values are calculated for All Movement Classes of All Heavy Vehicle Model Designation.

Arrival Flows used in performance calculations are adjusted to include any Initial Queued Demand and Upstream Capacity Constraint effects.

SITE LAYOUT

 Site: [1 (3)] Johnson & Sunrise Ridge - 2032 AM Without (Folder1)

New Site
Site Category: (None)
Roundabout
Site Scenario: 1 | Local Volumes

Layout pictures are schematic functional drawings reflecting input data. They are not design drawings.

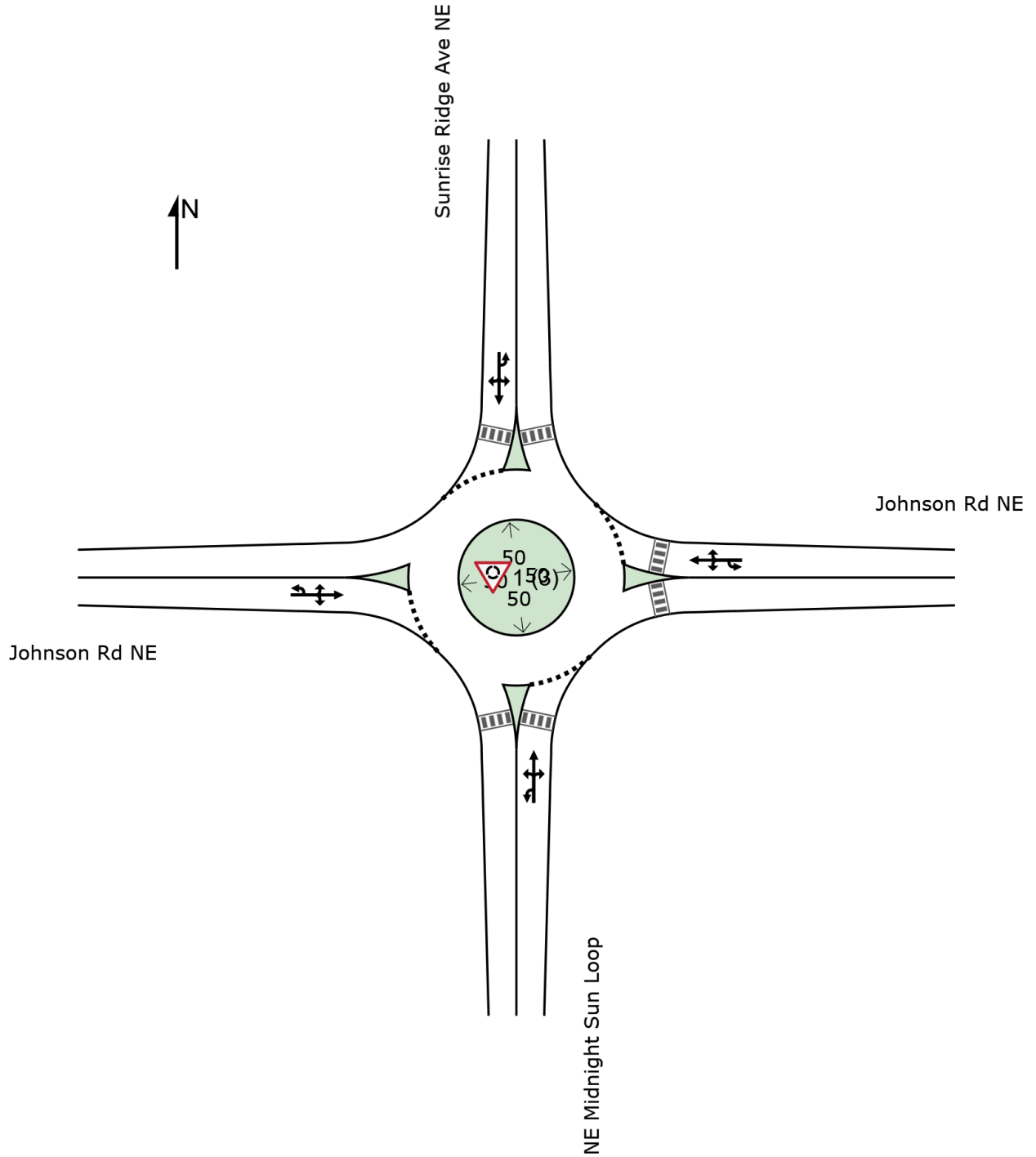

Intersection	
Intersection Delay, s/veh	22.6
Intersection LOS	C

Movement	EBL	EBT	EBR	WBL	WBT	WBR	NBL	NBT	NBR	SBL	SBT	SBR
Lane Configurations		↕			↕			↕			↕	↕
Traffic Vol, veh/h	48	236	23	22	213	81	61	38	41	129	27	60
Future Vol, veh/h	48	236	23	22	213	81	61	38	41	129	27	60
Peak Hour Factor	0.75	0.75	0.75	0.75	0.75	0.75	0.87	0.75	0.75	0.75	0.75	0.75
Heavy Vehicles, %	1	6	5	1	7	1	1	3	6	7	1	4
Mvmt Flow	64	315	31	29	284	108	70	51	55	172	36	80
Number of Lanes	0	1	0	0	1	0	0	1	0	0	1	1

Approach	EB	WB	NB	SB
Opposing Approach	WB	EB	SB	NB
Opposing Lanes	1	1	2	1
Conflicting Approach Left	SB	NB	EB	WB
Conflicting Lanes Left	2	1	1	1
Conflicting Approach Right	NB	SB	WB	EB
Conflicting Lanes Right	1	2	1	1
HCM Control Delay, s/veh	26.5	26.4	15	16.2
HCM LOS	D	D	B	C

Lane	NBLn1	EBLn1	WBLn1	SBLn1	SBLn2
Vol Left, %	44%	16%	7%	83%	0%
Vol Thru, %	27%	77%	67%	17%	0%
Vol Right, %	29%	7%	26%	0%	100%
Sign Control	Stop	Stop	Stop	Stop	Stop
Traffic Vol by Lane	140	307	316	156	60
LT Vol	61	48	22	129	0
Through Vol	38	236	213	27	0
RT Vol	41	23	81	0	60
Lane Flow Rate	175	409	421	208	80
Geometry Grp	4a	2	2	5	5
Degree of Util (U)	0.371	0.744	0.749	0.476	0.155
Departure Headway (Hd)	7.603	6.653	6.516	8.246	6.993
Convergence, U/N	les	les	les	les	les
Cap	475	549	560	439	516
Service Time	5.616	4.653	4.516	5.946	4.693
HCM Lane V/C Ratio	0.368	0.745	0.752	0.474	0.155
HCM Control Delay, s/veh	15	26.5	26.4	18.2	11
HCM Lane LOS	B	D	D	C	B
HCM 95th-tile Q	1.7	6.4	6.5	2.5	0.5

Intersection						
Int Delay, s/veh	3.9					
Movement	EBT	EBR	WBL	WBT	NBL	NBR
Lane Configurations						
Traffic Vol, veh/h	34	36	6	57	59	23
Future Vol, veh/h	34	36	6	57	59	23
Conflicting Peds, #/hr	0	10	10	0	10	10
Sign Control	Free	Free	Free	Free	Stop	Stop
RT Channelized	-	None	-	None	-	None
Storage Length	-	-	-	-	0	-
Veh in Median Storage, #	0	-	-	0	0	-
Grade, %	0	-	-	0	0	-
Peak Hour Factor	92	92	92	92	92	92
Heavy Vehicles, %	2	2	2	2	2	2
Mvmt Flow	37	39	7	62	64	25

























Major/Minor	Major1	Major2	Minor1			
Conflicting Flow All	0	0	86	0	152	77
Stage 1	-	-	-	-	67	-
Stage 2	-	-	-	-	85	-
Critical Hdwy	-	-	4.12	-	6.42	6.22
Critical Hdwy Stg 1	-	-	-	-	5.42	-
Critical Hdwy Stg 2	-	-	-	-	5.42	-
Follow-up Hdwy	-	-	2.218	-	3.518	3.318
Pot Cap-1 Maneuver	-	-	1510	-	840	985
Stage 1	-	-	-	-	956	-
Stage 2	-	-	-	-	938	-
Platoon blocked, %	-	-	-	-	-	-
Mov Cap-1 Maneuver	-	-	1498	-	823	968
Mov Cap-2 Maneuver	-	-	-	-	823	-
Stage 1	-	-	-	-	948	-
Stage 2	-	-	-	-	926	-

Approach	EB	WB	NB
HCM Ctrl Dly, s/v	0	0.71	9.68
HCM LOS			A

Minor Lane/Major Mvmt	NBLn1	EBT	EBR	WBL	WBT
Capacity (veh/h)	859	-	-	171	-
HCM Lane V/C Ratio	0.104	-	-	0.004	-
HCM Ctrl Dly (s/v)	9.7	-	-	7.4	0
HCM Lane LOS	A	-	-	A	A
HCM 95th %tile Q(veh)	0.3	-	-	0	-

HCM 7th Signalized Intersection Summary
1: SR305 & NE Hostmark St

Forecast 2032 PM Peak Hour
Without Project

												
Movement	EBL	EBT	EBR	WBL	WBT	WBR	NBL	NBT	NBR	SBL	SBT	SBR
Lane Configurations												
Traffic Volume (veh/h)	71	176	102	55	129	229	123	818	36	220	661	51
Future Volume (veh/h)	71	176	102	55	129	229	123	818	36	220	661	51
Initial Q (Qb), veh	0	0	0	0	0	0	0	0	0	0	0	0
Lane Width Adj.	1.00	1.00	1.00	1.00	1.00	1.00	1.00	1.00	1.00	1.00	1.00	1.00
Ped-Bike Adj(A_pbT)	0.99		0.96	0.99		0.96	1.00		0.96	1.00		0.97
Parking Bus, Adj	1.00	1.00	1.00	1.00	1.00	1.00	1.00	1.00	1.00	1.00	1.00	1.00
Work Zone On Approach		No			No			No			No	
Adj Sat Flow, veh/h/ln	1702	1758	1786	1786	1786	1786	1772	1744	1786	1786	1772	1744
Adj Flow Rate, veh/h	72	178	103	56	130	85	124	826	36	222	668	52
Peak Hour Factor	0.99	0.99	0.99	0.99	0.99	0.99	0.99	0.99	0.99	0.99	0.99	0.99
Percent Heavy Veh, %	7	3	1	1	1	1	2	4	1	1	2	4
Cap, veh/h	185	221	183	150	203	165	145	889	39	610	1624	126
Arrive On Green	0.05	0.13	0.13	0.04	0.11	0.11	0.09	0.31	0.31	0.36	0.59	0.59
Sat Flow, veh/h	1621	1758	1458	1701	1786	1455	1688	2831	123	1701	2768	215
Grp Volume(v), veh/h	72	178	103	56	130	85	124	361	501	222	303	417
Grp Sat Flow(s),veh/h/ln	1621	1758	1458	1701	1786	1455	1688	1238	1716	1701	1258	1726
Q Serve(g_s), s	4.7	11.8	8.0	3.5	8.4	3.4	8.7	33.9	33.9	11.6	15.8	15.8
Cycle Q Clear(g_c), s	4.7	11.8	8.0	3.5	8.4	3.4	8.7	33.9	33.9	11.6	15.8	15.8
Prop In Lane	1.00		1.00	1.00		1.00	1.00		0.07	1.00		0.12
Lane Grp Cap(c), veh/h	185	221	183	150	203	165	145	389	539	610	738	1012
V/C Ratio(X)	0.39	0.81	0.56	0.37	0.64	0.52	0.86	0.93	0.93	0.36	0.41	0.41
Avail Cap(c_a), veh/h	319	337	280	311	342	279	323	444	615	610	738	1012
HCM Platoon Ratio	1.00	1.00	1.00	1.00	1.00	1.00	1.00	1.00	1.00	1.00	1.00	1.00
Upstream Filter(I)	1.00	1.00	1.00	1.00	1.00	1.00	1.00	1.00	1.00	1.00	1.00	1.00
Uniform Delay (d), s/veh	44.5	51.0	49.3	45.5	50.9	13.1	54.1	39.9	39.9	28.4	13.5	13.5
Incr Delay (d2), s/veh	1.3	8.0	2.7	1.5	3.4	2.5	13.2	30.8	24.6	0.4	1.7	1.2
Initial Q Delay(d3), s/veh	0.0	0.0	0.0	0.0	0.0	0.0	0.0	0.0	0.0	0.0	0.0	0.0
%ile BackOfQ(95%),veh/ln	3.5	9.6	5.5	2.8	7.1	4.4	7.5	19.3	24.4	8.2	8.0	10.2
Unsig. Movement Delay, s/veh												
LnGrp Delay(d), s/veh	45.9	59.1	52.0	47.0	54.2	15.6	67.3	70.6	64.5	28.8	15.2	14.8
LnGrp LOS	D	E	D	D	D	B	E	E	E	C	B	B
Approach Vol, veh/h		353			271			986			942	
Approach Delay, s/veh		54.3			40.6			67.1			18.2	
Approach LOS		D			D			E			B	
Timer - Assigned Phs	1	2	3	4	5	6	7	8				
Phs Duration (G+Y+Rc), s	48.0	42.7	9.2	20.1	15.3	75.4	10.7	18.6				
Change Period (Y+Rc), s	4.5	4.5	4.5	4.5	4.5	4.5	4.5	4.5				
Max Green Setting (Gmax), s	18.9	43.5	16.1	23.5	23.5	38.9	16.1	23.5				
Max Q Clear Time (g_c+I1), s	13.6	35.9	5.5	13.8	10.7	17.8	6.7	10.4				
Green Ext Time (p_c), s	0.4	2.3	0.1	0.8	0.3	2.8	0.1	0.7				
Intersection Summary												
HCM 7th Control Delay, s/veh			44.5									
HCM 7th LOS			D									

Intersection						
Int Delay, s/veh	0.1					
Movement	EBL	EBT	WBT	WBR	SBL	SBR
Lane Configurations	↖	↗	↗	↖	↖	↖
Traffic Vol, veh/h	6	788	914	5	1	3
Future Vol, veh/h	6	788	914	5	1	3
Conflicting Peds, #/hr	1	0	0	1	1	1
Sign Control	Free	Free	Free	Free	Stop	Stop
RT Channelized	-	None	-	None	-	None
Storage Length	105	-	-	55	60	0
Veh in Median Storage, #	-	0	0	-	0	-
Grade, %	-	0	0	-	0	-
Peak Hour Factor	93	93	93	93	93	93
Heavy Vehicles, %	10	2	3	1	10	1
Mvmt Flow	6	847	983	5	1	3

Major/Minor	Major1	Major2	Minor2		
Conflicting Flow All	989	0	-	0	1845 985
Stage 1	-	-	-	-	984 -
Stage 2	-	-	-	-	861 -
Critical Hdwy	4.2	-	-	-	6.5 6.21
Critical Hdwy Stg 1	-	-	-	-	5.5 -
Critical Hdwy Stg 2	-	-	-	-	5.5 -
Follow-up Hdwy	2.29	-	-	-	3.59 3.309
Pot Cap-1 Maneuver	668	-	-	-	78 302
Stage 1	-	-	-	-	350 -
Stage 2	-	-	-	-	401 -
Platoon blocked, %		-	-	-	
Mov Cap-1 Maneuver	667	-	-	-	78 302
Mov Cap-2 Maneuver	-	-	-	-	78 -
Stage 1	-	-	-	-	346 -
Stage 2	-	-	-	-	401 -

Approach	EB	WB	SB
HCM Ctrl Dly, s/v	0.08	0	25.81
HCM LOS			D

Minor Lane/Major Mvmt	EBL	EBT	WBT	WBR	SBLn1	SBLn2
Capacity (veh/h)	667	-	-	-	78	302
HCM Lane V/C Ratio	0.01	-	-	-	0.014	0.011
HCM Ctrl Dly (s/v)	10.4	-	-	-	52.1	17.1
HCM Lane LOS	B	-	-	-	F	C
HCM 95th %tile Q(veh)	0	-	-	-	0	0

MOVEMENT SUMMARY

 Site: [99 (5)] SR 305 & Johnson Rd - Forecast 2032 PM
Without (PM Peak Hour)

Output produced by SIDRA INTERSECTION Version: 10.0.5.217

New Site
Site Category: (None)
Roundabout
Site Scenario: 1 | Local Volumes

Vehicle Movement Performance															
Mov ID	Turn	Mov Class	Demand Flows		Arrival Flows		Deg. Satn	Aver. Delay	Level of Service	95% Back Of Queue		Prop. Qued	Eff. Stop Rate	Number of Cycles to Depart	Aver. Speed
			[Total HV]	[Total HV]	[Total HV]	[Total HV]	v/c	sec		[Veh.]	[Dist]				mph
			veh/h	%	veh/h	%				veh	ft				
South: Johnson Way															
3u	U	All MCs	1	1.0	1	1.0	0.054	14.8	LOS B	0.2	5.2	0.55	0.74	0.55	31.1
3	L2	All MCs	23	6.0	23	6.0	0.054	11.7	LOS B	0.2	5.2	0.55	0.74	0.55	32.3
8	T1	All MCs	6	1.0	6	1.0	0.054	5.7	LOS A	0.2	5.2	0.55	0.74	0.55	30.3
18	R2	All MCs	9	1.0	9	1.0	0.054	7.9	LOS A	0.2	5.2	0.55	0.74	0.55	33.4
Approach			39	3.9	39	3.9	0.054	10.0	LOS A	0.2	5.2	0.55	0.74	0.55	32.2
East: SR 305															
1u	U	All MCs	3	1.0	3	1.0	0.471	12.1	LOS B	3.7	95.6	0.23	0.45	0.23	37.5
1	L2	All MCs	12	1.0	12	1.0	0.471	11.5	LOS B	3.7	95.6	0.23	0.45	0.23	35.6
6	T1	All MCs	949	3.0	949	3.0	0.471	6.5	LOS A	3.7	95.6	0.22	0.46	0.22	41.1
16	R2	All MCs	27	10.0	27	10.0	0.214	6.0	LOS A	1.2	31.6	0.19	0.46	0.19	35.9
Approach			991	3.2	991	3.2	0.471	6.5	LOS A	3.7	95.6	0.22	0.46	0.22	40.8
North: Johnson Rd															
7u	U	All MCs	1	1.0	1	1.0	0.076	15.4	LOS B	0.3	7.6	0.59	0.77	0.59	30.7
7	L2	All MCs	32	6.0	32	6.0	0.076	12.5	LOS B	0.3	7.6	0.59	0.77	0.59	31.9
4	T1	All MCs	3	1.0	3	1.0	0.076	6.3	LOS A	0.3	7.6	0.59	0.77	0.59	30.0
14	R2	All MCs	14	1.0	14	1.0	0.076	9.3	LOS A	0.3	7.6	0.59	0.77	0.59	32.9
Approach			51	4.2	51	4.2	0.076	11.3	LOS B	0.3	7.6	0.59	0.77	0.59	32.0
West: SR 305															
5u	U	All MCs	1	1.0	1	1.0	0.403	12.1	LOS B	2.9	74.3	0.23	0.46	0.23	37.5
5	L2	All MCs	11	1.0	11	1.0	0.403	11.5	LOS B	2.9	74.3	0.23	0.46	0.23	35.6
2	T1	All MCs	817	2.0	817	2.0	0.403	6.3	LOS A	2.9	74.3	0.23	0.46	0.23	41.2
12	R2	All MCs	23	1.0	23	1.0	0.183	5.9	LOS A	1.0	25.9	0.21	0.47	0.21	36.1
Approach			852	2.0	852	2.0	0.403	6.3	LOS A	2.9	74.3	0.23	0.46	0.23	41.0
All Vehicles			1932	2.7	1932	2.7	0.471	6.6	LOS A	3.7	95.6	0.24	0.47	0.24	40.4

Site Level of Service (LOS) Method: Delay & Degree of Saturation (SIDRA). Site LOS Method is specified in the Parameter Settings dialog (Options tab).

Roundabout LOS Method: Same as Signalised Intersections.

Vehicle movement LOS values are based on average delay and v/c ratio (degree of saturation) per movement.

Intersection and Approach LOS values are based on average delay for all movements (v/c not used).

Roundabout Capacity Model: SIDRA HCM.

Delay Model: SIDRA Standard (Control Delay: Geometric Delay is included).

Queue Model: SIDRA queue estimation methods are used for Back of Queue and Queue at Start of Gap.

Gap-Acceptance Capacity Formula: SIDRA Standard (Akçelik M3D).

HV (%) values are calculated for All Movement Classes of All Heavy Vehicle Model Designation.

Arrival Flows used in performance calculations are adjusted to include any Initial Queued Demand and Upstream Capacity Constraint effects.

SITE LAYOUT

 Site: [99 (5)] SR 305 & Johnson Rd - Forecast 2032 PM
Without (PM Peak Hour)

New Site
Site Category: (None)
Roundabout
Site Scenario: 1 | Local Volumes

Layout pictures are schematic functional drawings reflecting input data. They are not design drawings.

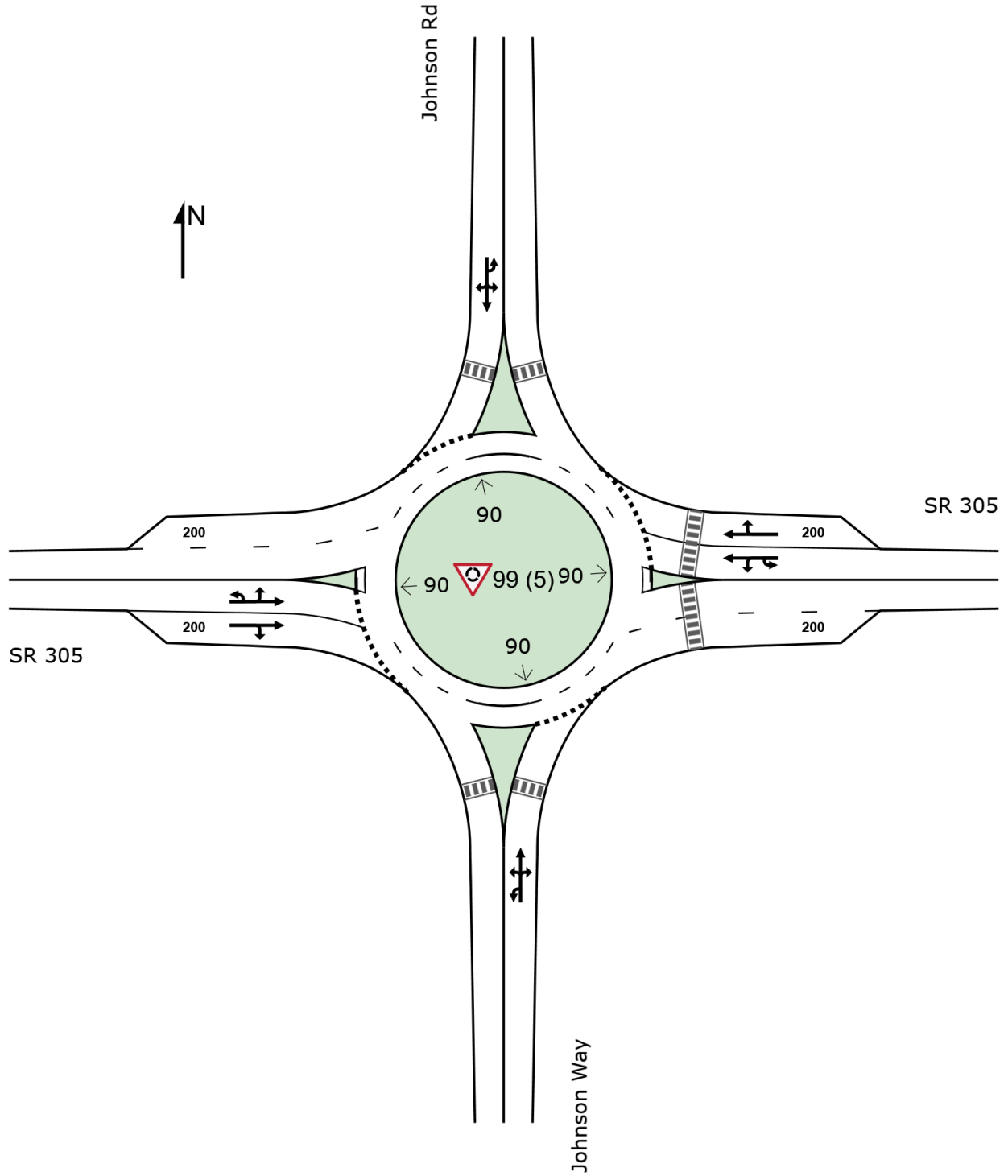

MOVEMENT SUMMARY

 Site: [1 (5)] Johnson & Sunrise Ridge - 2032 PM Without (Folder1)

Output produced by SIDRA INTERSECTION Version: 10.0.5.217

New Site
 Site Category: (None)
 Roundabout
 Site Scenario: 1 | Local Volumes

Vehicle Movement Performance															
Mov ID	Turn	Mov Class	Demand Flows		Arrival Flows		Deg. Satn	Aver. Delay	Level of Service	95% Back Of Queue		Prop. Qued	Eff. Stop of Cycles	Number of Cycles to Depart	Aver. Speed
			[Total HV]	[Total HV]	[Total HV]	[Total HV]	v/c	sec		[Veh.]	[Dist]		Rate		mph
			veh/h	%	veh/h	%				veh	ft				
South: NE Midnight Sun Loop															
3u	U	All MCs	1	3.0	1	3.0	0.005	7.2	LOS A	0.0	0.5	0.16	0.42	0.16	23.6
3	L2	All MCs	1	3.0	1	3.0	0.005	5.8	LOS A	0.0	0.5	0.16	0.42	0.16	23.6
8	T1	All MCs	1	3.0	1	3.0	0.005	2.0	LOS A	0.0	0.5	0.16	0.42	0.16	23.9
18	R2	All MCs	3	3.0	3	3.0	0.005	2.3	LOS A	0.0	0.5	0.16	0.42	0.16	23.8
Approach			7	3.0	7	3.0	0.005	3.7	LOS A	0.0	0.5	0.16	0.42	0.16	23.7
East: Johnson Rd NE															
1u	U	All MCs	1	3.0	1	3.0	0.043	10.9	LOS B	0.2	4.5	0.12	0.49	0.12	34.5
1	L2	All MCs	3	3.0	3	3.0	0.043	9.0	LOS A	0.2	4.5	0.12	0.49	0.12	34.5
6	T1	All MCs	40	3.0	40	3.0	0.043	5.0	LOS A	0.2	4.5	0.12	0.49	0.12	35.2
16	R2	All MCs	12	3.0	12	3.0	0.043	4.7	LOS A	0.2	4.5	0.12	0.49	0.12	34.8
Approach			57	3.0	57	3.0	0.043	5.3	LOS A	0.2	4.5	0.12	0.49	0.12	35.0
North: Sunrise Ridge Ave NE															
7u	U	All MCs	1	3.0	1	3.0	0.029	11.0	LOS B	0.1	3.0	0.15	0.55	0.15	34.3
7	L2	All MCs	7	3.0	7	3.0	0.029	9.1	LOS A	0.1	3.0	0.15	0.55	0.15	34.3
4	T1	All MCs	1	3.0	1	3.0	0.029	5.0	LOS A	0.1	3.0	0.15	0.55	0.15	34.9
14	R2	All MCs	26	3.0	26	3.0	0.029	4.8	LOS A	0.1	3.0	0.15	0.55	0.15	34.6
Approach			35	3.0	35	3.0	0.029	5.8	LOS A	0.1	3.0	0.15	0.55	0.15	34.5
West: Johnson Rd NE															
5u	U	All MCs	1	3.0	1	3.0	0.041	10.8	LOS B	0.2	4.3	0.07	0.59	0.07	33.6
5	L2	All MCs	30	3.0	30	3.0	0.041	8.9	LOS A	0.2	4.3	0.07	0.59	0.07	33.6
2	T1	All MCs	20	3.0	20	3.0	0.041	4.9	LOS A	0.2	4.3	0.07	0.59	0.07	34.2
12	R2	All MCs	1	3.0	1	3.0	0.041	4.6	LOS A	0.2	4.3	0.07	0.59	0.07	33.9
Approach			52	3.0	52	3.0	0.041	7.3	LOS A	0.2	4.3	0.07	0.59	0.07	33.9
All Vehicles			151	3.0	151	3.0	0.043	6.0	LOS A	0.2	4.5	0.11	0.53	0.11	33.8

Site Level of Service (LOS) Method: Delay & Degree of Saturation (SIDRA). Site LOS Method is specified in the Parameter Settings dialog (Options tab).

Roundabout LOS Method: Same as Signalised Intersections.

Vehicle movement LOS values are based on average delay and v/c ratio (degree of saturation) per movement.

Intersection and Approach LOS values are based on average delay for all movements (v/c not used).

Roundabout Capacity Model: SIDRA HCM.

Delay Model: SIDRA Standard (Control Delay: Geometric Delay is included).

Queue Model: SIDRA queue estimation methods are used for Back of Queue and Queue at Start of Gap.

Gap-Acceptance Capacity Formula: SIDRA Standard (Akçelik M3D).

HV (%) values are calculated for All Movement Classes of All Heavy Vehicle Model Designation.

Arrival Flows used in performance calculations are adjusted to include any Initial Queued Demand and Upstream Capacity Constraint effects.

SITE LAYOUT

Site: [1 (5)] Johnson & Sunrise Ridge - 2032 PM Without (Folder1)

New Site
Site Category: (None)
Roundabout
Site Scenario: 1 | Local Volumes

Layout pictures are schematic functional drawings reflecting input data. They are not design drawings.

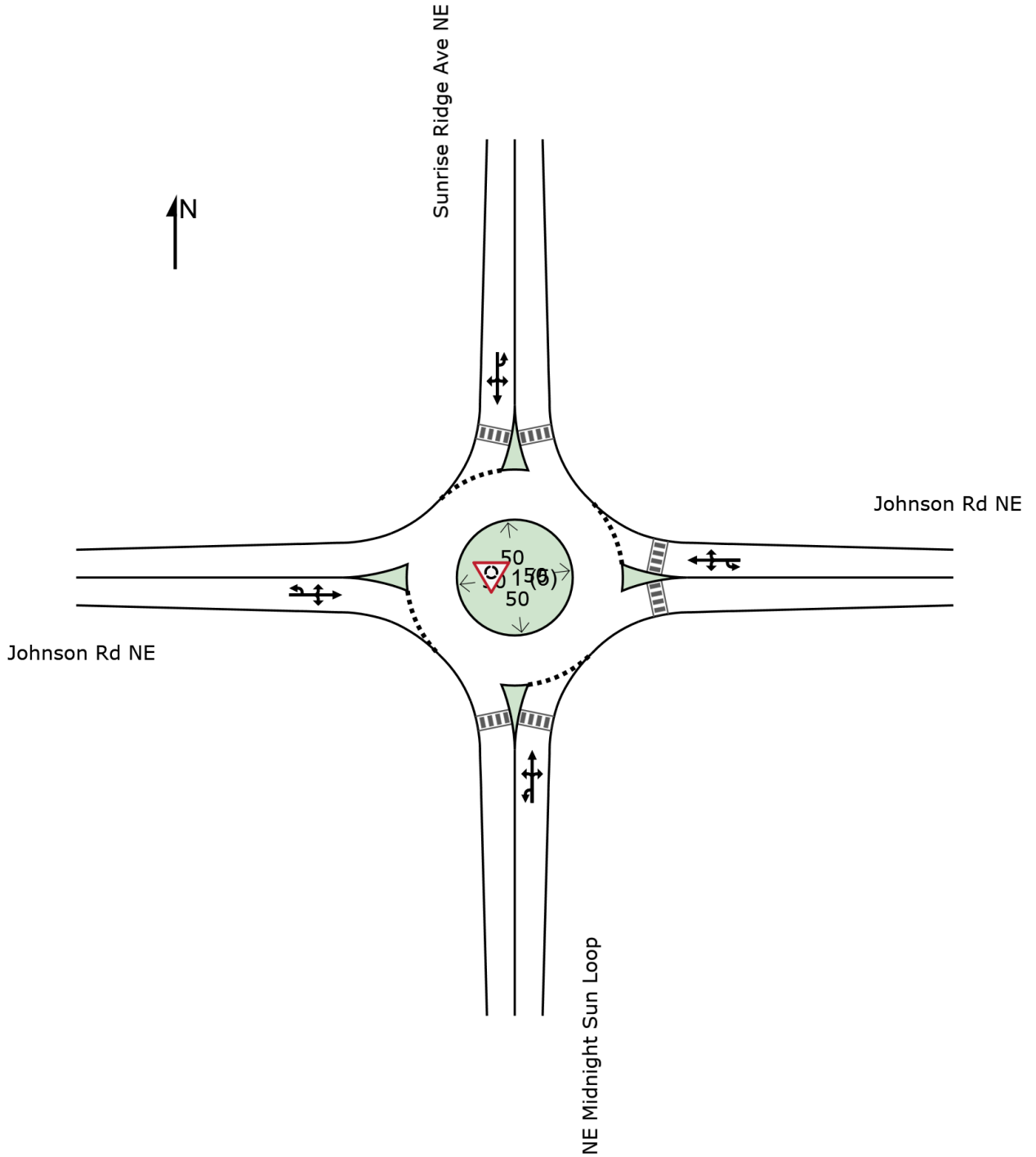

Intersection	
Intersection Delay, s/veh	14.9
Intersection LOS	B

Movement	EBL	EBT	EBR	WBL	WBT	WBR	NBL	NBT	NBR	SBL	SBT	SBR
Lane Configurations		↕			↕			↕			↕	↕
Traffic Vol, veh/h	89	219	72	10	137	50	65	50	3	92	63	65
Future Vol, veh/h	89	219	72	10	137	50	65	50	3	92	63	65
Peak Hour Factor	0.87	0.87	0.87	0.87	0.87	0.87	0.87	0.87	0.87	0.87	0.87	0.87
Heavy Vehicles, %	3	1	1	1	1	2	1	1	1	1	1	4
Mvmt Flow	102	252	83	11	157	57	75	57	3	106	72	75
Number of Lanes	0	1	0	0	1	0	0	1	0	0	1	1
Approach	EB			WB			NB			SB		
Opposing Approach	WB			EB			SB			NB		
Opposing Lanes	1			1			2			1		
Conflicting Approach Left	SB			NB			EB			WB		
Conflicting Lanes Left	2			1			1			1		
Conflicting Approach Right	NB			SB			WB			EB		
Conflicting Lanes Right	1			2			1			1		
HCM Control Delay, s/veh	18.9			12.1			11.8			12.2		
HCM LOS	C			B			B			B		

Lane	NBLn1	EBLn1	WBLn1	SBLn1	SBLn2
Vol Left, %	55%	23%	5%	59%	0%
Vol Thru, %	42%	58%	70%	41%	0%
Vol Right, %	3%	19%	25%	0%	100%
Sign Control	Stop	Stop	Stop	Stop	Stop
Traffic Vol by Lane	118	380	197	155	65
LT Vol	65	89	10	92	0
Through Vol	50	219	137	63	0
RT Vol	3	72	50	0	65
Lane Flow Rate	136	437	226	178	75
Geometry Grp	4a	2	2	5	5
Degree of Util (X)	0.246	0.666	0.361	0.343	0.123
Departure Headway (Hd)	6.521	5.489	5.74	6.925	5.908
Convergence, Y/N	Yes	Yes	Yes	Yes	Yes
Cap	547	655	620	517	602
Service Time	4.617	3.559	3.825	4.706	3.688
HCM Lane V/C Ratio	0.249	0.667	0.365	0.344	0.125
HCM Control Delay, s/veh	11.8	18.9	12.1	13.3	9.5
HCM Lane LOS	B	C	B	B	A
HCM 95th-tile Q	1	5	1.6	1.5	0.4

Intersection						
Int Delay, s/veh	2.9					
Movement	EBT	EBR	WBL	WBT	NBL	NBR
Lane Configurations						
Traffic Vol, veh/h	57	63	23	57	41	17
Future Vol, veh/h	57	63	23	57	41	17
Conflicting Peds, #/hr	0	10	10	0	10	10
Sign Control	Free	Free	Free	Free	Stop	Stop
RT Channelized	-	None	-	None	-	None
Storage Length	-	-	-	-	0	-
Veh in Median Storage, #	0	-	-	0	0	-
Grade, %	0	-	-	0	0	-
Peak Hour Factor	92	92	92	92	92	92
Heavy Vehicles, %	2	2	2	2	2	2
Mvmt Flow	62	68	25	62	45	18

Major/Minor	Major1	Major2	Minor1			
Conflicting Flow All	0	0	140	0	228	116
Stage 1	-	-	-	-	106	-
Stage 2	-	-	-	-	122	-
Critical Hdwy	-	-	4.12	-	6.42	6.22
Critical Hdwy Stg 1	-	-	-	-	5.42	-
Critical Hdwy Stg 2	-	-	-	-	5.42	-
Follow-up Hdwy	-	-	2.218	-	3.518	3.318
Pot Cap-1 Maneuver	-	-	1443	-	760	936
Stage 1	-	-	-	-	918	-
Stage 2	-	-	-	-	903	-
Platoon blocked, %	-	-	-	-	-	-
Mov Cap-1 Maneuver	-	-	1431	-	734	920
Mov Cap-2 Maneuver	-	-	-	-	734	-
Stage 1	-	-	-	-	910	-
Stage 2	-	-	-	-	880	-

Approach	EB	WB	NB
HCM Ctrl Dly, s/v	0	2.17	10.02
HCM LOS			B

Minor Lane/Major Mvmt	NBLn1	EBT	EBR	WBL	WBT
Capacity (veh/h)	780	-	-	517	-
HCM Lane V/C Ratio	0.081	-	-	0.017	-
HCM Ctrl Dly (s/v)	10	-	-	7.6	0
HCM Lane LOS	B	-	-	A	A
HCM 95th %tile Q(veh)	0.3	-	-	0.1	-

HCM 7th Signalized Intersection Summary
1: SR305 & NE Hostmark St

Forecast 2032 AM Peak Hour
With Project

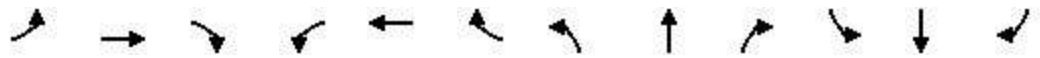

Movement	EBL	EBT	EBR	WBL	WBT	WBR	NBL	NBT	NBR	SBL	SBT	SBR
Lane Configurations												
Traffic Volume (veh/h)	39	108	70	54	89	150	61	509	22	208	888	21
Future Volume (veh/h)	39	108	70	54	89	150	61	509	22	208	888	21
Initial Q (Qb), veh	0	0	0	0	0	0	0	0	0	0	0	0
Lane Width Adj.	1.00	1.00	1.00	1.00	1.00	1.00	1.00	1.00	1.00	1.00	1.00	1.00
Ped-Bike Adj(A_pbT)	0.99		0.98	0.99		0.98	1.00		0.98	1.00		0.99
Parking Bus, Adj	1.00	1.00	1.00	1.00	1.00	1.00	1.00	1.00	1.00	1.00	1.00	1.00
Work Zone On Approach		No			No			No			No	
Adj Sat Flow, veh/h/ln	1716	1730	1744	1744	1744	1716	1730	1716	1716	1730	1716	1646
Adj Flow Rate, veh/h	42	117	76	59	97	98	66	553	24	226	965	23
Peak Hour Factor	0.92	0.92	0.92	0.92	0.92	0.92	0.92	0.92	0.92	0.92	0.92	0.92
Percent Heavy Veh, %	6	5	4	4	4	6	5	6	6	5	6	11
Cap, veh/h	172	176	147	165	198	162	78	620	27	776	1845	44
Arrive On Green	0.03	0.10	0.10	0.04	0.11	0.11	0.05	0.22	0.22	0.47	0.65	0.65
Sat Flow, veh/h	1634	1730	1443	1661	1744	1423	1647	2789	121	1647	2853	68
Grp Volume(v), veh/h	42	117	76	59	97	98	66	241	336	226	412	576
Grp Sat Flow(s),veh/h/ln	1634	1730	1443	1661	1744	1423	1647	1218	1691	1647	1218	1703
Q Serve(g_s), s	2.8	7.8	6.0	3.8	6.3	3.0	4.8	23.0	23.1	10.1	21.7	21.7
Cycle Q Clear(g_c), s	2.8	7.8	6.0	3.8	6.3	3.0	4.8	23.0	23.1	10.1	21.7	21.7
Prop In Lane	1.00		1.00	1.00		1.00	1.00		0.07	1.00		0.04
Lane Grp Cap(c), veh/h	172	176	147	165	198	162	78	271	376	776	788	1101
V/C Ratio(X)	0.24	0.67	0.52	0.36	0.49	0.61	0.85	0.89	0.89	0.29	0.52	0.52
Avail Cap(c_a), veh/h	342	332	277	318	334	273	316	437	606	776	788	1101
HCM Platoon Ratio	1.00	1.00	1.00	1.00	1.00	1.00	1.00	1.00	1.00	1.00	1.00	1.00
Upstream Filter(I)	1.00	1.00	1.00	1.00	1.00	1.00	1.00	1.00	1.00	1.00	1.00	1.00
Uniform Delay (d), s/veh	47.0	51.9	51.1	46.3	49.9	7.5	56.8	45.2	45.3	19.4	11.3	11.3
Incr Delay (d2), s/veh	0.7	4.3	2.8	1.3	1.9	3.6	21.7	32.5	25.8	0.2	2.5	1.8
Initial Q Delay(d3), s/veh	0.0	0.0	0.0	0.0	0.0	0.0	0.0	0.0	0.0	0.0	0.0	0.0
%ile BackOfQ(95%),veh/ln	2.1	6.5	4.1	2.9	5.1	5.1	4.4	14.2	17.9	6.8	9.8	12.5
Unsig. Movement Delay, s/veh												
LnGrp Delay(d), s/veh	47.7	56.2	53.9	47.6	51.8	11.1	78.4	77.7	71.1	19.6	13.8	13.1
LnGrp LOS	D	E	D	D	D	B	E	E	E	B	B	B
Approach Vol, veh/h		235			254			643			1214	
Approach Delay, s/veh		54.0			35.1			74.3			14.6	
Approach LOS		D			D			E			B	
Timer - Assigned Phs	1	2	3	4	5	6	7	8				
Phs Duration (G+Y+Rc), s	61.5	31.7	9.6	17.2	10.6	82.6	8.1	18.6				
Change Period (Y+Rc), s	4.5	4.5	4.5	4.5	4.5	4.5	4.5	4.5				
Max Green Setting (Gmax), s	18.9	43.5	16.1	23.5	23.5	38.9	16.1	23.5				
Max Q Clear Time (g_c+I1), s	12.1	25.1	5.8	9.8	6.8	23.7	4.8	8.3				
Green Ext Time (p_c), s	0.4	2.1	0.1	0.6	0.1	3.8	0.1	0.6				
Intersection Summary												
HCM 7th Control Delay, s/veh				37.1								
HCM 7th LOS				D								

Intersection						
Int Delay, s/veh	0.1					
Movement	EBL	EBT	WBT	WBR	SBL	SBR
Lane Configurations	↘	↗	↗	↘	↘	↘
Traffic Vol, veh/h	0	983	547	1	2	3
Future Vol, veh/h	0	983	547	1	2	3
Conflicting Peds, #/hr	4	0	0	4	4	4
Sign Control	Free	Free	Free	Free	Stop	Stop
RT Channelized	-	None	-	None	-	None
Storage Length	105	-	-	55	60	0
Veh in Median Storage, #	-	0	0	-	0	-
Grade, %	-	0	0	-	0	-
Peak Hour Factor	93	93	93	93	93	93
Heavy Vehicles, %	1	8	6	1	1	1
Mvmt Flow	0	1057	588	1	2	3

Major/Minor	Major1	Major2	Minor2		
Conflicting Flow All	593	0	-	0	1653 596
Stage 1	-	-	-	-	592 -
Stage 2	-	-	-	-	1061 -
Critical Hdwy	4.11	-	-	-	6.41 6.21
Critical Hdwy Stg 1	-	-	-	-	5.41 -
Critical Hdwy Stg 2	-	-	-	-	5.41 -
Follow-up Hdwy	2.209	-	-	-	3.509 3.309
Pot Cap-1 Maneuver	988	-	-	-	109 505
Stage 1	-	-	-	-	555 -
Stage 2	-	-	-	-	334 -
Platoon blocked, %		-	-	-	
Mov Cap-1 Maneuver	984	-	-	-	108 502
Mov Cap-2 Maneuver	-	-	-	-	108 -
Stage 1	-	-	-	-	553 -
Stage 2	-	-	-	-	333 -

Approach	EB	WB	SB
HCM Ctrl Dly, s/v	0	0	22.92
HCM LOS			C

Minor Lane/Major Mvmt	EBL	EBT	WBT	WBR	SBLn1	SBLn2
Capacity (veh/h)	984	-	-	-	108	502
HCM Lane V/C Ratio	-	-	-	-	0.02	0.006
HCM Ctrl Dly (s/v)	0	-	-	-	39	12.2
HCM Lane LOS	A	-	-	-	E	B
HCM 95th %tile Q(veh)	0	-	-	-	0.1	0

MOVEMENT SUMMARY

 Site: [99 (4)] SR 305 & Johnson Rd - Forecast 2032 AM With (AM Peak Hour)

Output produced by SIDRA INTERSECTION Version: 10.0.9.250

New Site
 Site Category: (None)
 Roundabout
Site Scenario: 1 | Local Volumes

Vehicle Movement Performance															
Mov ID	Turn	Mov Class	Demand Flows		Arrival Flows		Deg. Satn	Aver. Delay	Level of Service	95% Back Of Queue		Prop. Qued	Eff. Stop of Cycles	Number of Cycles to Depart	Aver. Speed
			[Total HV]	[Total HV]	[Total HV]	[Total HV]	v/c	sec		[Veh.]	[Dist]		Rate		mph
			veh/h	%	veh/h	%				veh	ft				
South: Johnson Way															
3u	U	All MCs	1	1.0	1	1.0	0.053	16.6	LOS B	0.2	6.0	0.69	0.81	0.69	30.4
3	L2	All MCs	18	1.0	18	1.0	0.053	13.2	LOS B	0.2	6.0	0.69	0.81	0.69	32.1
8	T1	All MCs	8	1.0	8	1.0	0.053	7.5	LOS A	0.2	6.0	0.69	0.81	0.69	29.7
18	R2	All MCs	3	1.0	3	1.0	0.053	13.7	LOS B	0.2	6.0	0.69	0.81	0.69	32.5
Approach			30	1.0	30	1.0	0.053	11.9	LOS B	0.2	6.0	0.69	0.81	0.69	31.5
East: SR 305															
1u	U	All MCs	1	1.0	1	1.0	0.275	12.1	LOS B	1.7	43.4	0.21	0.46	0.21	37.6
1	L2	All MCs	8	1.0	8	1.0	0.275	11.5	LOS B	1.7	43.4	0.21	0.46	0.21	35.7
6	T1	All MCs	522	6.0	522	6.0	0.275	6.1	LOS A	1.7	43.4	0.20	0.46	0.20	40.6
16	R2	All MCs	27	1.0	27	1.0	0.125	5.9	LOS A	0.6	16.6	0.20	0.47	0.20	36.1
Approach			557	5.7	557	5.7	0.275	6.2	LOS A	1.7	43.4	0.20	0.46	0.20	40.3
North: Johnson Rd															
7u	U	All MCs	1	1.0	1	1.0	0.206	14.1	LOS B	0.8	21.0	0.50	0.70	0.50	31.2
7	L2	All MCs	122	3.0	122	3.0	0.206	10.8	LOS B	0.8	21.0	0.50	0.70	0.50	32.8
4	T1	All MCs	2	1.0	2	1.0	0.206	5.0	LOS A	0.8	21.0	0.50	0.70	0.50	30.5
14	R2	All MCs	52	1.0	52	1.0	0.206	6.4	LOS A	0.8	21.0	0.50	0.70	0.50	33.5
Approach			176	2.4	176	2.4	0.206	9.5	LOS A	0.8	21.0	0.50	0.70	0.50	33.0
West: SR 305															
5u	U	All MCs	1	1.0	1	1.0	0.576	12.7	LOS B	5.1	135.4	0.49	0.51	0.49	36.6
5	L2	All MCs	24	17.0	24	17.0	0.576	12.7	LOS B	5.1	135.4	0.49	0.51	0.49	34.2
2	T1	All MCs	1015	8.0	1015	8.0	0.576	8.0	LOS A	5.1	135.4	0.46	0.51	0.46	39.2
12	R2	All MCs	20	12.0	20	12.0	0.262	6.7	LOS A	1.5	41.2	0.38	0.50	0.38	35.3
Approach			1060	8.3	1060	8.3	0.576	8.1	LOS A	5.1	135.4	0.46	0.51	0.46	39.0
All Vehicles			1824	6.8	1824	6.8	0.576	7.7	LOS A	5.1	135.4	0.39	0.52	0.39	38.5

Site Level of Service (LOS) Method: Delay & Degree of Saturation (SIDRA). Site LOS Method is specified in the Parameter Settings dialog (Options tab).

Roundabout LOS Method: Same as Signalised Intersections.

Vehicle movement LOS values are based on average delay and v/c ratio (degree of saturation) per movement.

Intersection and Approach LOS values are based on average delay for all movements (v/c not used).

Roundabout Capacity Model: SIDRA HCM.

Delay Model: SIDRA Standard (Control Delay: Geometric Delay is included).

Queue Model: SIDRA queue estimation methods are used for Back of Queue and Queue at Start of Gap.

Gap-Acceptance Capacity Formula: SIDRA Standard (Akçelik M3D).

HV (%) values are calculated for All Movement Classes of All Heavy Vehicle Model Designation.

Arrival Flows used in performance calculations are adjusted to include any Initial Queued Demand and Upstream Capacity Constraint effects.

SITE LAYOUT

 Site: [99 (4)] SR 305 & Johnson Rd - Forecast 2032 AM With (AM Peak Hour)

New Site
Site Category: (None)
Roundabout
Site Scenario: 1 | Local Volumes

Layout pictures are schematic functional drawings reflecting input data. They are not design drawings.

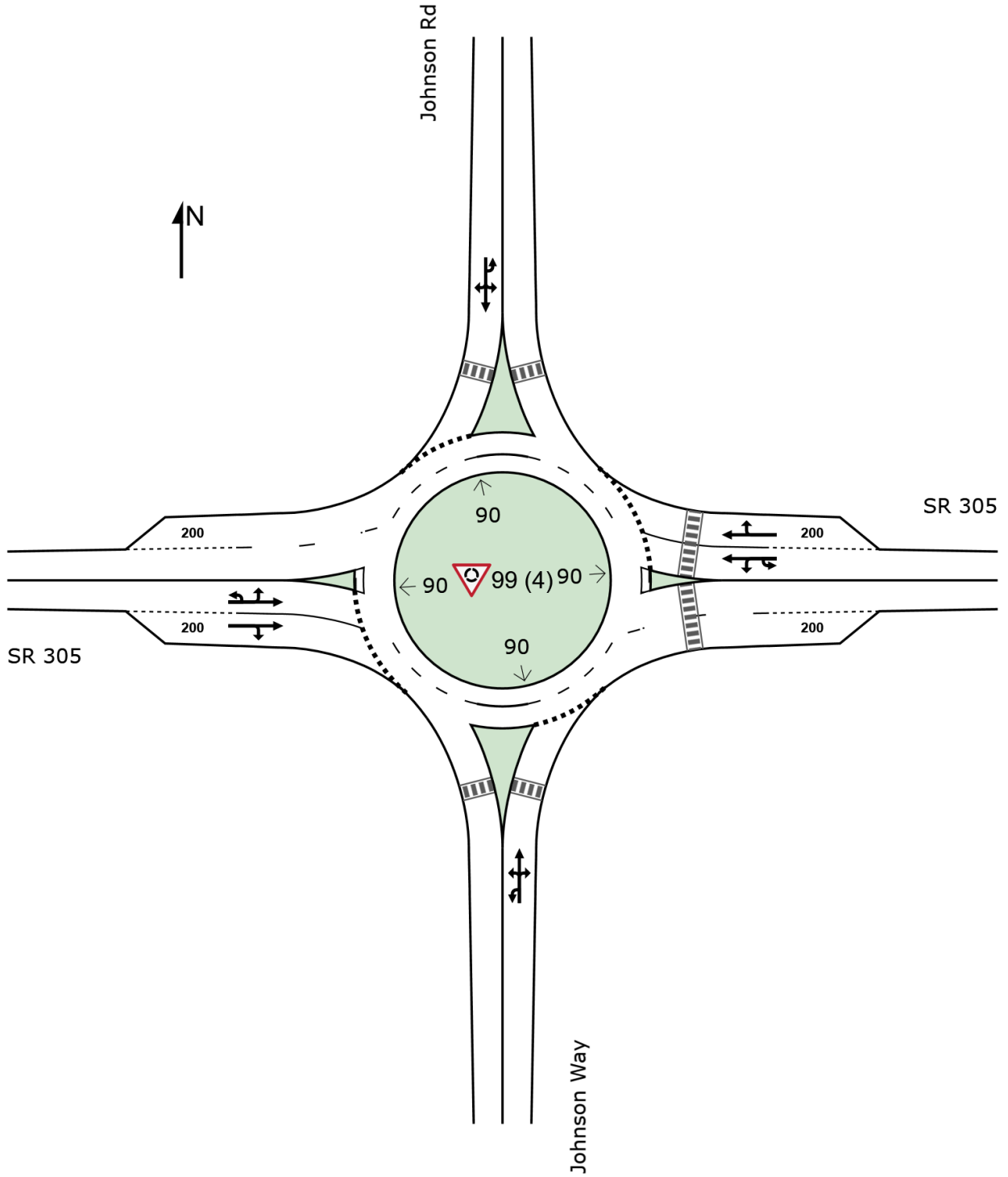

MOVEMENT SUMMARY

Site: [1 (4)] Johnson & Sunrise Ridge - 2032 AM With (Folder1)

Output produced by SIDRA INTERSECTION Version: 10.0.9.250

New Site
 Site Category: (None)
 Roundabout
 Site Scenario: 1 | Local Volumes

Vehicle Movement Performance															
Mov ID	Turn	Mov Class	Demand Flows		Arrival Flows		Deg. Satn	Aver. Delay	Level of Service	95% Back Of Queue		Prop. Qued	Eff. Stop of Cycles	Number of Cycles to Depart	Aver. Speed
			[Total HV]	[Total HV]	[Total HV]	[Total HV]	v/c	sec		[Veh.]	[Dist]		Rate		mph
			veh/h	%	veh/h	%				veh	ft				
South: NE Midnight Sun Loop															
3u	U	All MCs	1	3.0	1	3.0	0.004	7.3	LOSA	0.0	0.4	0.20	0.45	0.20	23.5
3	L2	All MCs	1	3.0	1	3.0	0.004	5.9	LOSA	0.0	0.4	0.20	0.45	0.20	23.5
8	T1	All MCs	1	3.0	1	3.0	0.004	2.1	LOSA	0.0	0.4	0.20	0.45	0.20	23.7
18	R2	All MCs	1	3.0	1	3.0	0.004	2.4	LOSA	0.0	0.4	0.20	0.45	0.20	23.6
Approach			5	3.0	5	3.0	0.004	4.4	LOSA	0.0	0.4	0.20	0.45	0.20	23.5
East: Johnson Rd NE															
1u	U	All MCs	1	3.0	1	3.0	0.073	11.0	LOS B	0.3	7.9	0.14	0.46	0.14	34.5
1	L2	All MCs	1	3.0	1	3.0	0.073	9.1	LOSA	0.3	7.9	0.14	0.46	0.14	34.5
6	T1	All MCs	87	3.0	87	3.0	0.073	5.0	LOSA	0.3	7.9	0.14	0.46	0.14	35.2
16	R2	All MCs	6	3.0	6	3.0	0.073	4.8	LOSA	0.3	7.9	0.14	0.46	0.14	34.9
Approach			95	3.0	95	3.0	0.073	5.1	LOSA	0.3	7.9	0.14	0.46	0.14	35.1
North: Sunrise Ridge Ave NE															
7u	U	All MCs	1	3.0	1	3.0	0.116	11.2	LOS B	0.5	13.2	0.23	0.54	0.23	34.3
7	L2	All MCs	19	3.0	19	3.0	0.116	9.3	LOSA	0.5	13.2	0.23	0.54	0.23	34.3
4	T1	All MCs	1	3.0	1	3.0	0.116	5.3	LOSA	0.5	13.2	0.23	0.54	0.23	34.9
14	R2	All MCs	114	3.0	114	3.0	0.116	5.0	LOSA	0.5	13.2	0.23	0.54	0.23	34.6
Approach			136	3.0	136	3.0	0.116	5.7	LOSA	0.5	13.2	0.23	0.54	0.23	34.5
West: Johnson Rd NE															
5u	U	All MCs	1	3.0	1	3.0	0.061	10.9	LOS B	0.3	6.7	0.11	0.58	0.11	33.7
5	L2	All MCs	40	3.0	40	3.0	0.061	9.0	LOSA	0.3	6.7	0.11	0.58	0.11	33.7
2	T1	All MCs	26	3.0	26	3.0	0.061	4.9	LOSA	0.3	6.7	0.11	0.58	0.11	34.3
12	R2	All MCs	10	3.0	10	3.0	0.061	4.7	LOSA	0.3	6.7	0.11	0.58	0.11	34.0
Approach			77	3.0	77	3.0	0.061	7.1	LOSA	0.3	6.7	0.11	0.58	0.11	33.9
All Vehicles			313	3.0	313	3.0	0.116	5.8	LOSA	0.5	13.2	0.17	0.53	0.17	34.3

Site Level of Service (LOS) Method: Delay & Degree of Saturation (SIDRA). Site LOS Method is specified in the Parameter Settings dialog (Options tab).

Roundabout LOS Method: Same as Signalised Intersections.

Vehicle movement LOS values are based on average delay and v/c ratio (degree of saturation) per movement.

Intersection and Approach LOS values are based on average delay for all movements (v/c not used).

Roundabout Capacity Model: SIDRA HCM.

Delay Model: SIDRA Standard (Control Delay: Geometric Delay is included).

Queue Model: SIDRA queue estimation methods are used for Back of Queue and Queue at Start of Gap.

Gap-Acceptance Capacity Formula: SIDRA Standard (Akçelik M3D).

HV (%) values are calculated for All Movement Classes of All Heavy Vehicle Model Designation.

Arrival Flows used in performance calculations are adjusted to include any Initial Queued Demand and Upstream Capacity Constraint effects.

SITE LAYOUT

 Site: [1 (4)] Johnson & Sunrise Ridge - 2032 AM With (Folder1)

New Site
Site Category: (None)
Roundabout
Site Scenario: 1 | Local Volumes

Layout pictures are schematic functional drawings reflecting input data. They are not design drawings.

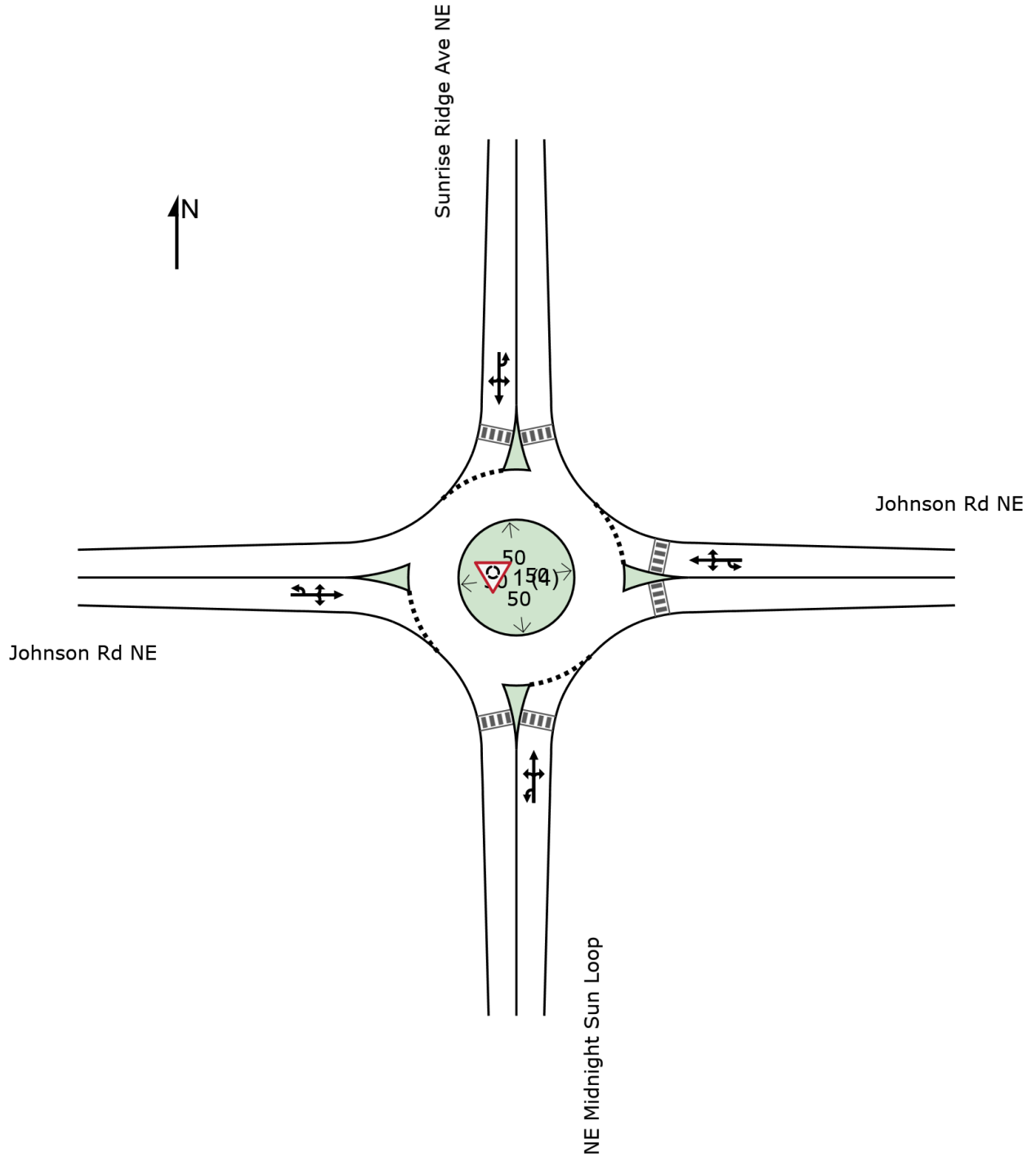

Intersection						
Int Delay, s/veh	6.4					
Movement	EBL	EBR	NBL	NBT	SBT	SBR
Lane Configurations						
Traffic Vol, veh/h	7	64	23	8	19	3
Future Vol, veh/h	7	64	23	8	19	3
Conflicting Peds, #/hr	0	0	0	0	0	0
Sign Control	Stop	Stop	Free	Free	Free	Free
RT Channelized	-	None	-	None	-	None
Storage Length	0	-	-	-	-	-
Veh in Median Storage, #	0	-	-	0	0	-
Grade, %	0	-	-	0	0	-
Peak Hour Factor	92	92	92	92	92	92
Heavy Vehicles, %	2	2	2	2	2	2
Mvmt Flow	8	70	25	9	21	3

Major/Minor	Minor2	Major1		Major2	
Conflicting Flow All	81	22	24	0	0
Stage 1	22	-	-	-	-
Stage 2	59	-	-	-	-
Critical Hdwy	6.42	6.22	4.12	-	-
Critical Hdwy Stg 1	5.42	-	-	-	-
Critical Hdwy Stg 2	5.42	-	-	-	-
Follow-up Hdwy	3.518	3.318	2.218	-	-
Pot Cap-1 Maneuver	921	1055	1591	-	-
Stage 1	1000	-	-	-	-
Stage 2	964	-	-	-	-
Platoon blocked, %				-	-
Mov Cap-1 Maneuver	907	1055	1591	-	-
Mov Cap-2 Maneuver	907	-	-	-	-
Stage 1	985	-	-	-	-
Stage 2	964	-	-	-	-

Approach	EB	NB	SB
HCM Ctrl Dly, s/v	8.75	5.42	0
HCM LOS	A		

Minor Lane/Major Mvmt	NBL	NBT	EBLn1	SBT	SBR
Capacity (veh/h)	1335	-	1038	-	-
HCM Lane V/C Ratio	0.016	-	0.074	-	-
HCM Ctrl Dly (s/v)	7.3	0	8.7	-	-
HCM Lane LOS	A	A	A	-	-
HCM 95th %tile Q(veh)	0	-	0.2	-	-

Intersection	
Intersection Delay, s/veh	24.2
Intersection LOS	C

Movement	EBL	EBT	EBR	WBL	WBT	WBR	NBL	NBT	NBR	SBL	SBT	SBR
Lane Configurations		↕			↕			↕			↕	↕
Traffic Vol, veh/h	48	236	23	24	213	81	61	41	45	129	28	60
Future Vol, veh/h	48	236	23	24	213	81	61	41	45	129	28	60
Peak Hour Factor	0.75	0.75	0.75	0.75	0.75	0.75	0.87	0.75	0.75	0.75	0.75	0.75
Heavy Vehicles, %	1	6	5	1	7	1	1	3	6	7	1	4
Mvmt Flow	64	315	31	32	284	108	70	55	60	172	37	80
Number of Lanes	0	1	0	0	1	0	0	1	0	0	1	1

Approach	EB	WB	NB	SB
Opposing Approach	WB	EB	SB	NB
Opposing Lanes	1	1	2	1
Conflicting Approach Left	SB	NB	EB	WB
Conflicting Lanes Left	2	1	1	1
Conflicting Approach Right	NB	SB	WB	EB
Conflicting Lanes Right	1	2	1	1
HCM Control Delay, s/veh	28.5	28.9	15.6	16.5
HCM LOS	D	D	C	C

Lane	NBLn1	EBLn1	WBLn1	SBLn1	SBLn2
Vol Left, %	41%	16%	8%	82%	0%
Vol Thru, %	28%	77%	67%	18%	0%
Vol Right, %	31%	7%	25%	0%	100%
Sign Control	Stop	Stop	Stop	Stop	Stop
Traffic Vol by Lane	147	307	318	157	60
LT Vol	61	48	24	129	0
Through Vol	41	236	213	28	0
RT Vol	45	23	81	0	60
Lane Flow Rate	185	409	424	209	80
Geometry Grp	4a	2	2	5	5
Degree of Util (X)	0.393	0.766	0.777	0.483	0.157
Departure Headway (Hd)	7.649	6.739	6.597	8.307	7.056
Convergence, Y/N	Yes	Yes	Yes	Yes	Yes
Cap	469	540	551	433	507
Service Time	5.722	4.761	4.617	6.071	4.82
HCM Lane V/C Ratio	0.394	0.757	0.77	0.483	0.158
HCM Control Delay, s/veh	15.6	28.5	28.9	18.6	11.1
HCM Lane LOS	C	D	D	C	B
HCM 95th-tile Q	1.8	6.8	7.1	2.6	0.6

Intersection						
Int Delay, s/veh	4.1					
Movement	EBT	EBR	WBL	WBT	NBL	NBR
Lane Configurations						
Traffic Vol, veh/h	34	39	6	57	66	23
Future Vol, veh/h	34	39	6	57	66	23
Conflicting Peds, #/hr	0	10	10	0	10	10
Sign Control	Free	Free	Free	Free	Stop	Stop
RT Channelized	-	None	-	None	-	None
Storage Length	-	-	-	-	0	-
Veh in Median Storage, #	0	-	-	0	0	-
Grade, %	0	-	-	0	0	-
Peak Hour Factor	92	92	92	92	92	92
Heavy Vehicles, %	2	2	2	2	2	2
Mvmt Flow	37	42	7	62	72	25

Major/Minor	Major1	Major2	Minor1			
Conflicting Flow All	0	0	89	0	153	78
Stage 1	-	-	-	-	68	-
Stage 2	-	-	-	-	85	-
Critical Hdwy	-	-	4.12	-	6.42	6.22
Critical Hdwy Stg 1	-	-	-	-	5.42	-
Critical Hdwy Stg 2	-	-	-	-	5.42	-
Follow-up Hdwy	-	-	2.218	-	3.518	3.318
Pot Cap-1 Maneuver	-	-	1506	-	838	982
Stage 1	-	-	-	-	955	-
Stage 2	-	-	-	-	938	-
Platoon blocked, %	-	-	-	-	-	-
Mov Cap-1 Maneuver	-	-	1493	-	821	966
Mov Cap-2 Maneuver	-	-	-	-	821	-
Stage 1	-	-	-	-	947	-
Stage 2	-	-	-	-	926	-

Approach	EB	WB	NB
HCM Ctrl Dly, s/v	0	0.71	9.75
HCM LOS			A

Minor Lane/Major Mvmt	NBLn1	EBT	EBR	WBL	WBT
Capacity (veh/h)	854	-	-	171	-
HCM Lane V/C Ratio	0.113	-	-	0.004	-
HCM Ctrl Dly (s/v)	9.8	-	-	7.4	0
HCM Lane LOS	A	-	-	A	A
HCM 95th %tile Q(veh)	0.4	-	-	0	-

HCM 7th Signalized Intersection Summary
1: SR305 & NE Hostmark St

Forecast 2032 PM Peak Hour
With Project



Movement	EBL	EBT	EBR	WBL	WBT	WBR	NBL	NBT	NBR	SBL	SBT	SBR
Lane Configurations												
Traffic Volume (veh/h)	71	176	118	55	129	229	133	830	36	220	681	51
Future Volume (veh/h)	71	176	118	55	129	229	133	830	36	220	681	51
Initial Q (Qb), veh	0	0	0	0	0	0	0	0	0	0	0	0
Lane Width Adj.	1.00	1.00	1.00	1.00	1.00	1.00	1.00	1.00	1.00	1.00	1.00	1.00
Ped-Bike Adj(A_pbT)	0.99		0.96	0.99		0.96	1.00		0.96	1.00		0.97
Parking Bus, Adj	1.00	1.00	1.00	1.00	1.00	1.00	1.00	1.00	1.00	1.00	1.00	1.00
Work Zone On Approach		No			No			No			No	
Adj Sat Flow, veh/h/ln	1702	1758	1786	1786	1786	1786	1772	1744	1786	1786	1772	1744
Adj Flow Rate, veh/h	72	178	119	56	130	85	134	838	36	222	688	52
Peak Hour Factor	0.99	0.99	0.99	0.99	0.99	0.99	0.99	0.99	0.99	0.99	0.99	0.99
Percent Heavy Veh, %	7	3	1	1	1	1	2	4	1	1	2	4
Cap, veh/h	186	222	184	150	203	166	156	900	39	603	1609	122
Arrive On Green	0.05	0.13	0.13	0.04	0.11	0.11	0.09	0.32	0.32	0.35	0.58	0.58
Sat Flow, veh/h	1621	1758	1459	1701	1786	1455	1688	2833	122	1701	2775	210
Grp Volume(v), veh/h	72	178	119	56	130	85	134	366	508	222	312	428
Grp Sat Flow(s),veh/h/ln	1621	1758	1459	1701	1786	1455	1688	1238	1717	1701	1258	1727
Q Serve(g_s), s	4.7	11.8	9.3	3.5	8.3	3.4	9.4	34.4	34.4	11.6	16.6	16.6
Cycle Q Clear(g_c), s	4.7	11.8	9.3	3.5	8.3	3.4	9.4	34.4	34.4	11.6	16.6	16.6
Prop In Lane	1.00		1.00	1.00		1.00	1.00		0.07	1.00		0.12
Lane Grp Cap(c), veh/h	186	222	184	150	203	166	156	393	545	603	730	1001
V/C Ratio(X)	0.39	0.80	0.65	0.37	0.64	0.51	0.86	0.93	0.93	0.37	0.43	0.43
Avail Cap(c_a), veh/h	320	337	280	311	342	279	323	444	615	603	730	1001
HCM Platoon Ratio	1.00	1.00	1.00	1.00	1.00	1.00	1.00	1.00	1.00	1.00	1.00	1.00
Upstream Filter(I)	1.00	1.00	1.00	1.00	1.00	1.00	1.00	1.00	1.00	1.00	1.00	1.00
Uniform Delay (d), s/veh	44.5	51.0	49.9	45.4	50.8	13.3	53.7	39.7	39.7	28.8	14.1	14.1
Incr Delay (d2), s/veh	1.3	7.9	3.8	1.5	3.3	2.5	12.8	30.9	24.8	0.4	1.8	1.3
Initial Q Delay(d3), s/veh	0.0	0.0	0.0	0.0	0.0	0.0	0.0	0.0	0.0	0.0	0.0	0.0
%ile BackOfQ(95%),veh/ln	3.5	9.6	6.5	2.8	7.1	4.4	7.9	19.5	24.6	8.3	8.4	10.6
Unsig. Movement Delay, s/veh												
LnGrp Delay(d), s/veh	45.8	58.9	53.7	47.0	54.1	15.7	66.5	70.6	64.5	29.1	15.9	15.4
LnGrp LOS	D	E	D	D	D	B	E	E	E	C	B	B
Approach Vol, veh/h		369			271			1008			962	
Approach Delay, s/veh		54.7			40.6			67.0			18.7	
Approach LOS		D			D			E			B	
Timer - Assigned Phs	1	2	3	4	5	6	7	8				
Phs Duration (G+Y+Rc), s	47.5	43.1	9.2	20.1	16.1	74.6	10.7	18.7				
Change Period (Y+Rc), s	4.5	4.5	4.5	4.5	4.5	4.5	4.5	4.5				
Max Green Setting (Gmax), s	18.9	43.5	16.1	23.5	23.5	38.9	16.1	23.5				
Max Q Clear Time (g_c+I1), s	13.6	36.4	5.5	13.8	11.4	18.6	6.7	10.3				
Green Ext Time (p_c), s	0.4	2.2	0.1	0.8	0.3	2.9	0.1	0.7				
Intersection Summary												
HCM 7th Control Delay, s/veh			44.7									
HCM 7th LOS			D									

Intersection						
Int Delay, s/veh	0.1					
Movement	EBL	EBT	WBT	WBR	SBL	SBR
Lane Configurations	↖	↗	↗	↖	↖	↖
Traffic Vol, veh/h	6	824	936	5	1	3
Future Vol, veh/h	6	824	936	5	1	3
Conflicting Peds, #/hr	1	0	0	1	1	1
Sign Control	Free	Free	Free	Free	Stop	Stop
RT Channelized	-	None	-	None	-	None
Storage Length	105	-	-	55	60	0
Veh in Median Storage, #	-	0	0	-	0	-
Grade, %	-	0	0	-	0	-
Peak Hour Factor	93	93	93	93	93	93
Heavy Vehicles, %	10	2	3	1	10	1
Mvmt Flow	6	886	1006	5	1	3

Major/Minor	Major1	Major2	Minor2
Conflicting Flow All	1013	0	0
Stage 1	-	-	-
Stage 2	-	-	-
Critical Hdwy	4.2	-	-
Critical Hdwy Stg 1	-	-	-
Critical Hdwy Stg 2	-	-	-
Follow-up Hdwy	2.29	-	-
Pot Cap-1 Maneuver	654	-	-
Stage 1	-	-	-
Stage 2	-	-	-
Platoon blocked, %	-	-	-
Mov Cap-1 Maneuver	654	-	-
Mov Cap-2 Maneuver	-	-	-
Stage 1	-	-	-
Stage 2	-	-	-

Approach	EB	WB	SB
HCM Ctrl Dly, s/v	0.08	0	27.24
HCM LOS			D

Minor Lane/Major Mvmt	EBL	EBT	WBT	WBR	SBLn1	SBLn2
Capacity (veh/h)	654	-	-	-	71	293
HCM Lane V/C Ratio	0.01	-	-	-	0.015	0.011
HCM Ctrl Dly (s/v)	10.6	-	-	-	56.6	17.4
HCM Lane LOS	B	-	-	-	F	C
HCM 95th %tile Q(veh)	0	-	-	-	0	0

MOVEMENT SUMMARY

 Site: [99 (6)] SR 305 & Johnson Rd - Forecast 2032 PM With (PM Peak Hour)

Output produced by SIDRA INTERSECTION Version: 10.0.9.250

New Site
 Site Category: (None)
 Roundabout
 Site Scenario: 1 | Local Volumes

Vehicle Movement Performance															
Mov ID	Turn	Mov Class	Demand Flows		Arrival Flows		Deg. Satn	Aver. Delay	Level of Service	95% Back Of Queue		Prop. Qued	Eff. Stop Rate	Number of Cycles to Depart	Aver. Speed
			[Total HV]	[Total HV]	[Total HV]	[Total HV]	v/c	sec		[Veh.]	[Dist]				mph
			veh/h	%	veh/h	%				veh	ft				
South: Johnson Way															
3u	U	All MCs	1	1.0	1	1.0	0.057	15.0	LOS B	0.2	5.7	0.58	0.75	0.58	31.0
3	L2	All MCs	23	6.0	23	6.0	0.057	12.0	LOS B	0.2	5.7	0.58	0.75	0.58	32.2
8	T1	All MCs	6	1.0	6	1.0	0.057	6.0	LOS A	0.2	5.7	0.58	0.75	0.58	30.2
18	R2	All MCs	9	1.0	9	1.0	0.057	8.2	LOS A	0.2	5.7	0.58	0.75	0.58	33.2
Approach			39	3.9	39	3.9	0.057	10.3	LOS B	0.2	5.7	0.58	0.75	0.58	32.0
East: SR 305															
1u	U	All MCs	3	1.0	3	1.0	0.504	12.3	LOS B	3.9	99.3	0.32	0.47	0.32	37.2
1	L2	All MCs	12	1.0	12	1.0	0.504	11.7	LOS B	3.9	99.3	0.32	0.47	0.32	35.3
6	T1	All MCs	949	3.0	949	3.0	0.504	6.7	LOS A	3.9	99.3	0.31	0.47	0.31	40.7
16	R2	All MCs	61	10.0	61	10.0	0.229	6.3	LOS A	1.3	32.5	0.27	0.49	0.27	35.6
Approach			1026	3.4	1026	3.4	0.504	6.7	LOS A	3.9	99.3	0.30	0.47	0.30	40.3
North: Johnson Rd															
7u	U	All MCs	1	1.0	1	1.0	0.147	15.7	LOS B	0.6	15.7	0.63	0.78	0.63	30.7
7	L2	All MCs	53	6.0	53	6.0	0.147	12.8	LOS B	0.6	15.7	0.63	0.78	0.63	31.9
4	T1	All MCs	3	1.0	3	1.0	0.147	6.6	LOS A	0.6	15.7	0.63	0.78	0.63	30.0
14	R2	All MCs	38	1.0	38	1.0	0.147	9.8	LOS A	0.6	15.7	0.63	0.78	0.63	33.0
Approach			95	3.8	95	3.8	0.147	11.5	LOS B	0.6	15.7	0.63	0.78	0.63	32.3
West: SR 305															
5u	U	All MCs	1	1.0	1	1.0	0.431	12.2	LOS B	3.3	83.6	0.30	0.48	0.30	37.1
5	L2	All MCs	49	1.0	49	1.0	0.431	11.6	LOS B	3.3	83.6	0.30	0.48	0.30	35.2
2	T1	All MCs	817	2.0	817	2.0	0.431	6.4	LOS A	3.3	83.6	0.29	0.48	0.29	40.8
12	R2	All MCs	23	1.0	23	1.0	0.196	6.0	LOS A	1.1	28.2	0.26	0.47	0.26	35.9
Approach			890	1.9	890	1.9	0.431	6.7	LOS A	3.3	83.6	0.29	0.48	0.29	40.3
All Vehicles			2049	2.8	2049	2.8	0.504	7.0	LOS A	3.9	99.3	0.32	0.49	0.32	39.6

Site Level of Service (LOS) Method: Delay & Degree of Saturation (SIDRA). Site LOS Method is specified in the Parameter Settings dialog (Options tab).

Roundabout LOS Method: Same as Signalised Intersections.

Vehicle movement LOS values are based on average delay and v/c ratio (degree of saturation) per movement.

Intersection and Approach LOS values are based on average delay for all movements (v/c not used).

Roundabout Capacity Model: SIDRA HCM.

Delay Model: SIDRA Standard (Control Delay: Geometric Delay is included).

Queue Model: SIDRA queue estimation methods are used for Back of Queue and Queue at Start of Gap.

Gap-Acceptance Capacity Formula: SIDRA Standard (Akçelik M3D).

HV (%) values are calculated for All Movement Classes of All Heavy Vehicle Model Designation.

Arrival Flows used in performance calculations are adjusted to include any Initial Queued Demand and Upstream Capacity Constraint effects.

SITE LAYOUT

 Site: [99 (6)] SR 305 & Johnson Rd - Forecast 2032 PM With (PM Peak Hour)

New Site
Site Category: (None)
Roundabout
Site Scenario: 1 | Local Volumes

Layout pictures are schematic functional drawings reflecting input data. They are not design drawings.

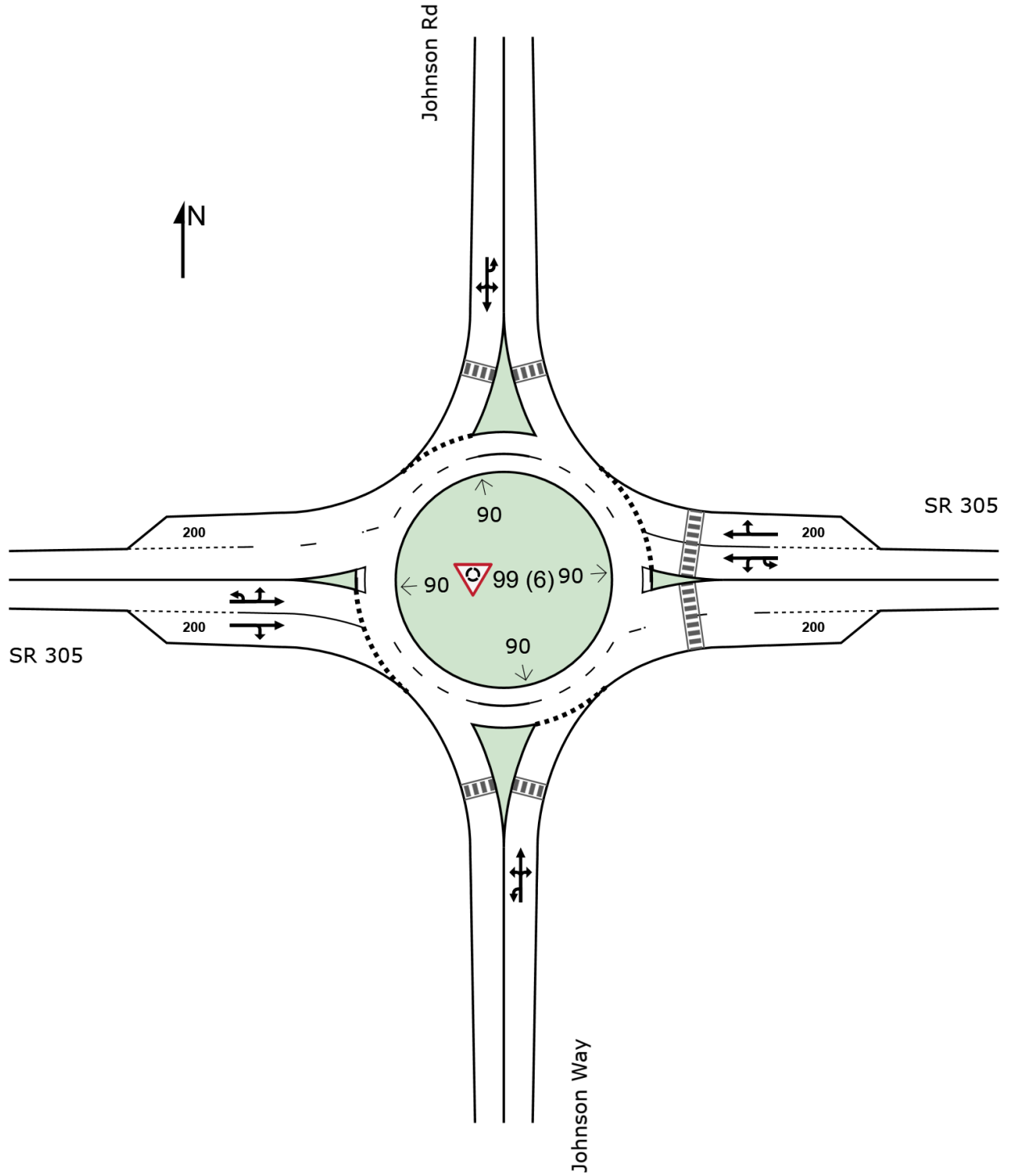

MOVEMENT SUMMARY

 Site: [1 (6)] Johnson & Sunrise Ridge - 2032 PM With (Folder1)

Output produced by SIDRA INTERSECTION Version: 10.0.9.250

New Site

Site Category: (None)

Roundabout

Site Scenario: 1 | Local Volumes

Vehicle Movement Performance															
Mov ID	Turn	Mov Class	Demand Flows		Arrival Flows		Deg. Satn	Aver. Delay	Level of Service	95% Back Of Queue		Prop. Qued	Eff. Stop Rate	Number of Cycles to Depart	Aver. Speed
			[Total HV]	[Total HV]	[Total HV]	[Total HV]	v/c	sec		[Veh.]	[Dist]				mph
			veh/h	%	veh/h	%				veh	ft				
South: NE Midnight Sun Loop															
3u	U	All MCs	1	3.0	1	3.0	0.006	7.5	LOS A	0.0	0.6	0.25	0.43	0.25	23.6
3	L2	All MCs	1	3.0	1	3.0	0.006	6.1	LOS A	0.0	0.6	0.25	0.43	0.25	23.6
8	T1	All MCs	1	3.0	1	3.0	0.006	2.3	LOS A	0.0	0.6	0.25	0.43	0.25	23.8
18	R2	All MCs	3	3.0	3	3.0	0.006	2.6	LOS A	0.0	0.6	0.25	0.43	0.25	23.7
Approach			7	3.0	7	3.0	0.006	4.0	LOS A	0.0	0.6	0.25	0.43	0.25	23.6
East: Johnson Rd NE															
1u	U	All MCs	1	3.0	1	3.0	0.050	11.2	LOS B	0.2	5.3	0.23	0.50	0.23	34.3
1	L2	All MCs	3	3.0	3	3.0	0.050	9.3	LOS A	0.2	5.3	0.23	0.50	0.23	34.3
6	T1	All MCs	40	3.0	40	3.0	0.050	5.3	LOS A	0.2	5.3	0.23	0.50	0.23	34.9
16	R2	All MCs	17	3.0	17	3.0	0.050	5.0	LOS A	0.2	5.3	0.23	0.50	0.23	34.6
Approach			61	3.0	61	3.0	0.050	5.5	LOS A	0.2	5.3	0.23	0.50	0.23	34.8
North: Sunrise Ridge Ave NE															
7u	U	All MCs	1	3.0	1	3.0	0.069	11.0	LOS B	0.3	7.7	0.16	0.53	0.16	34.5
7	L2	All MCs	9	3.0	9	3.0	0.069	9.1	LOS A	0.3	7.7	0.16	0.53	0.16	34.5
4	T1	All MCs	1	3.0	1	3.0	0.069	5.0	LOS A	0.3	7.7	0.16	0.53	0.16	35.1
14	R2	All MCs	73	3.0	73	3.0	0.069	4.8	LOS A	0.3	7.7	0.16	0.53	0.16	34.8
Approach			84	3.0	84	3.0	0.069	5.3	LOS A	0.3	7.7	0.16	0.53	0.16	34.8
West: Johnson Rd NE															
5u	U	All MCs	1	3.0	1	3.0	0.101	10.9	LOS B	0.4	11.2	0.08	0.63	0.08	33.1
5	L2	All MCs	107	3.0	107	3.0	0.101	8.9	LOS A	0.4	11.2	0.08	0.63	0.08	33.1
2	T1	All MCs	20	3.0	20	3.0	0.101	4.9	LOS A	0.4	11.2	0.08	0.63	0.08	33.7
12	R2	All MCs	1	3.0	1	3.0	0.101	4.6	LOS A	0.4	11.2	0.08	0.63	0.08	33.4
Approach			130	3.0	130	3.0	0.101	8.3	LOS A	0.4	11.2	0.08	0.63	0.08	33.2
All Vehicles			282	3.0	282	3.0	0.101	6.7	LOS A	0.4	11.2	0.14	0.57	0.14	33.7

Site Level of Service (LOS) Method: Delay & Degree of Saturation (SIDRA). Site LOS Method is specified in the Parameter Settings dialog (Options tab).

Roundabout LOS Method: Same as Signalised Intersections.

Vehicle movement LOS values are based on average delay and v/c ratio (degree of saturation) per movement.

Intersection and Approach LOS values are based on average delay for all movements (v/c not used).

Roundabout Capacity Model: SIDRA HCM.

Delay Model: SIDRA Standard (Control Delay: Geometric Delay is included).

Queue Model: SIDRA queue estimation methods are used for Back of Queue and Queue at Start of Gap.

Gap-Acceptance Capacity Formula: SIDRA Standard (Akçelik M3D).

HV (%) values are calculated for All Movement Classes of All Heavy Vehicle Model Designation.

Arrival Flows used in performance calculations are adjusted to include any Initial Queued Demand and Upstream Capacity Constraint effects.

SITE LAYOUT

 Site: [1 (6)] Johnson & Sunrise Ridge - 2032 PM With (Folder1)

New Site
Site Category: (None)
Roundabout
Site Scenario: 1 | Local Volumes

Layout pictures are schematic functional drawings reflecting input data. They are not design drawings.

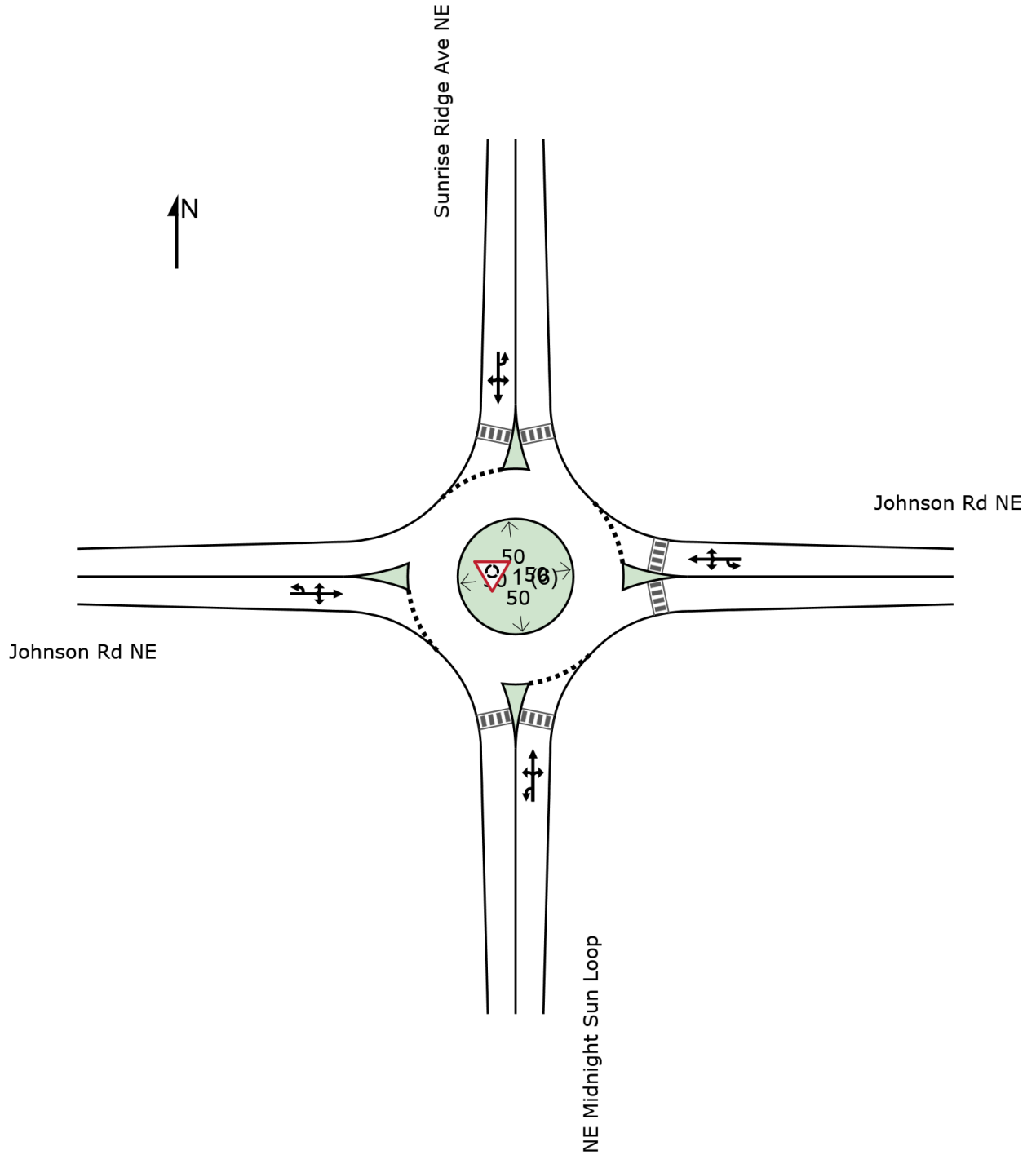

Intersection						
Int Delay, s/veh	6.5					
Movement	EBL	EBR	NBL	NBT	SBT	SBR
Lane Configurations	W			W	W	
Traffic Vol, veh/h	5	43	72	7	12	8
Future Vol, veh/h	5	43	72	7	12	8
Conflicting Peds, #/hr	0	0	0	0	0	0
Sign Control	Stop	Stop	Free	Free	Free	Free
RT Channelized	-	None	-	None	-	None
Storage Length	0	-	-	-	-	-
Veh in Median Storage, #	0	-	-	0	0	-
Grade, %	0	-	-	0	0	-
Peak Hour Factor	92	92	92	92	92	92
Heavy Vehicles, %	2	2	2	2	2	2
Mvmt Flow	5	47	78	8	13	9

Major/Minor	Minor2	Major1		Major2	
Conflicting Flow All	182	17	22	0	0
Stage 1	17	-	-	-	-
Stage 2	164	-	-	-	-
Critical Hdwy	6.42	6.22	4.12	-	-
Critical Hdwy Stg 1	5.42	-	-	-	-
Critical Hdwy Stg 2	5.42	-	-	-	-
Follow-up Hdwy	3.518	3.318	2.218	-	-
Pot Cap-1 Maneuver	808	1061	1594	-	-
Stage 1	1005	-	-	-	-
Stage 2	865	-	-	-	-
Platoon blocked, %				-	-
Mov Cap-1 Maneuver	768	1061	1594	-	-
Mov Cap-2 Maneuver	768	-	-	-	-
Stage 1	956	-	-	-	-
Stage 2	865	-	-	-	-

Approach	EB	NB	SB
HCM Ctrl Dly, s/v	8.72	6.72	0
HCM LOS	A		

Minor Lane/Major Mvmt	NBL	NBT	EBLn1	SBT	SBR
Capacity (veh/h)	1587	-	1021	-	-
HCM Lane V/C Ratio	0.049	-	0.051	-	-
HCM Ctrl Dly (s/v)	7.4	0	8.7	-	-
HCM Lane LOS	A	A	A	-	-
HCM 95th %tile Q(veh)	0.2	-	0.2	-	-

Intersection	
Intersection Delay, s/veh	15.1
Intersection LOS	C

Movement	EBL	EBT	EBR	WBL	WBT	WBR	NBL	NBT	NBR	SBL	SBT	SBR
Lane Configurations		↕			↕			↕			↕	↕
Traffic Vol, veh/h	89	219	72	14	137	50	65	52	6	92	67	65
Future Vol, veh/h	89	219	72	14	137	50	65	52	6	92	67	65
Peak Hour Factor	0.87	0.87	0.87	0.87	0.87	0.87	0.87	0.87	0.87	0.87	0.87	0.87
Heavy Vehicles, %	3	1	1	1	1	2	1	1	1	1	1	4
Mvmt Flow	102	252	83	16	157	57	75	60	7	106	77	75
Number of Lanes	0	1	0	0	1	0	0	1	0	0	1	1

Approach	EB	WB	NB	SB
Opposing Approach	WB	EB	SB	NB
Opposing Lanes	1	1	2	1
Conflicting Approach Left	SB	NB	EB	WB
Conflicting Lanes Left	2	1	1	1
Conflicting Approach Right	NB	SB	WB	EB
Conflicting Lanes Right	1	2	1	1
HCM Control Delay, s/veh	19.3	12.3	11.9	12.4
HCM LOS	C	B	B	B

Lane	NBLn1	EBLn1	WBLn1	SBLn1	SBLn2
Vol Left, %	53%	23%	7%	58%	0%
Vol Thru, %	42%	58%	68%	42%	0%
Vol Right, %	5%	19%	25%	0%	100%
Sign Control	Stop	Stop	Stop	Stop	Stop
Traffic Vol by Lane	123	380	201	159	65
LT Vol	65	89	14	92	0
Through Vol	52	219	137	67	0
RT Vol	6	72	50	0	65
Lane Flow Rate	141	437	231	183	75
Geometry Grp	4a	2	2	5	5
Degree of Util (X)	0.257	0.672	0.372	0.353	0.123
Departure Headway (Hd)	6.547	5.541	5.796	6.957	5.948
Convergence, Y/N	Yes	Yes	Yes	Yes	Yes
Cap	544	646	615	514	598
Service Time	4.646	3.613	3.884	4.743	3.733
HCM Lane V/C Ratio	0.259	0.676	0.376	0.356	0.125
HCM Control Delay, s/veh	11.9	19.3	12.3	13.5	9.6
HCM Lane LOS	B	C	B	B	A
HCM 95th-tile Q	1	5.1	1.7	1.6	0.4

Intersection						
Int Delay, s/veh	3					
Movement	EBT	EBR	WBL	WBT	NBL	NBR
Lane Configurations						
Traffic Vol, veh/h	57	71	23	57	46	17
Future Vol, veh/h	57	71	23	57	46	17
Conflicting Peds, #/hr	0	10	10	0	10	10
Sign Control	Free	Free	Free	Free	Stop	Stop
RT Channelized	-	None	-	None	-	None
Storage Length	-	-	-	-	0	-
Veh in Median Storage, #	0	-	-	0	0	-
Grade, %	0	-	-	0	0	-
Peak Hour Factor	92	92	92	92	92	92
Heavy Vehicles, %	2	2	2	2	2	2
Mvmt Flow	62	77	25	62	50	18

Major/Minor	Major1	Major2	Minor1		
Conflicting Flow All	0	0	149	0	233
Stage 1	-	-	-	-	111
Stage 2	-	-	-	-	122
Critical Hdwy	-	-	4.12	-	6.42
Critical Hdwy Stg 1	-	-	-	-	5.42
Critical Hdwy Stg 2	-	-	-	-	5.42
Follow-up Hdwy	-	-	2.218	-	3.518
Pot Cap-1 Maneuver	-	-	1432	-	756
Stage 1	-	-	-	-	914
Stage 2	-	-	-	-	903
Platoon blocked, %	-	-	-	-	-
Mov Cap-1 Maneuver	-	-	1420	-	730
Mov Cap-2 Maneuver	-	-	-	-	730
Stage 1	-	-	-	-	906
Stage 2	-	-	-	-	880

Approach	EB	WB	NB
HCM Ctrl Dly, s/v	0	2.18	10.12
HCM LOS			B

Minor Lane/Major Mvmt	NBLn1	EBT	EBR	WBL	WBT
Capacity (veh/h)	772	-	-	517	-
HCM Lane V/C Ratio	0.089	-	-	0.018	-
HCM Ctrl Dly (s/v)	10.1	-	-	7.6	0
HCM Lane LOS	B	-	-	A	A
HCM 95th %tile Q(veh)	0.3	-	-	0.1	-

THE PINNACLE AT LIBERTY BAY TRAFFIC IMPACT ANALYSIS

APPENDIX
Forecast 2037 Level of Service



HCM 7th Signalized Intersection Summary
1: SR305 & NE Hostmark St

Forecast 2037 AM Peak Hour
Without Project



Movement	EBL	EBT	EBR	WBL	WBT	WBR	NBL	NBT	NBR	SBL	SBT	SBR
Lane Configurations												
Traffic Volume (veh/h)	47	131	79	65	107	181	57	519	26	252	932	25
Future Volume (veh/h)	47	131	79	65	107	181	57	519	26	252	932	25
Initial Q (Qb), veh	0	0	0	0	0	0	0	0	0	0	0	0
Lane Width Adj.	1.00	1.00	1.00	1.00	1.00	1.00	1.00	1.00	1.00	1.00	1.00	1.00
Ped-Bike Adj(A_pbT)	0.99		0.98	0.99		0.98	1.00		0.98	1.00		0.99
Parking Bus, Adj	1.00	1.00	1.00	1.00	1.00	1.00	1.00	1.00	1.00	1.00	1.00	1.00
Work Zone On Approach		No			No			No			No	
Adj Sat Flow, veh/h/ln	1716	1730	1744	1744	1744	1716	1730	1716	1716	1730	1716	1646
Adj Flow Rate, veh/h	47	131	79	65	107	121	57	519	26	252	932	25
Peak Hour Factor	1.00	1.00	1.00	1.00	1.00	1.00	1.00	1.00	1.00	1.00	1.00	1.00
Percent Heavy Veh, %	6	5	4	4	4	6	5	6	6	5	6	11
Cap, veh/h	178	187	156	169	210	171	66	585	29	778	1829	49
Arrive On Green	0.03	0.11	0.11	0.04	0.12	0.12	0.04	0.21	0.21	0.47	0.64	0.64
Sat Flow, veh/h	1634	1730	1445	1661	1744	1425	1647	2767	138	1647	2843	76
Grp Volume(v), veh/h	47	131	79	65	107	121	57	228	317	252	399	558
Grp Sat Flow(s),veh/h/ln	1634	1730	1445	1661	1744	1425	1647	1218	1688	1647	1218	1701
Q Serve(g_s), s	3.1	8.8	6.2	4.2	6.9	3.7	4.1	21.8	21.9	11.4	20.9	20.9
Cycle Q Clear(g_c), s	3.1	8.8	6.2	4.2	6.9	3.7	4.1	21.8	21.9	11.4	20.9	20.9
Prop In Lane	1.00		1.00	1.00		1.00	1.00		0.08	1.00		0.04
Lane Grp Cap(c), veh/h	178	187	156	169	210	171	66	258	357	778	784	1095
V/C Ratio(X)	0.26	0.70	0.51	0.38	0.51	0.71	0.86	0.89	0.89	0.32	0.51	0.51
Avail Cap(c_a), veh/h	341	332	277	316	334	273	316	437	605	778	784	1095
HCM Platoon Ratio	1.00	1.00	1.00	1.00	1.00	1.00	1.00	1.00	1.00	1.00	1.00	1.00
Upstream Filter(I)	1.00	1.00	1.00	1.00	1.00	1.00	1.00	1.00	1.00	1.00	1.00	1.00
Uniform Delay (d), s/veh	46.1	51.7	50.5	45.5	49.5	7.3	57.3	45.9	45.9	19.7	11.4	11.4
Incr Delay (d2), s/veh	0.8	4.7	2.5	1.4	1.9	5.3	26.1	33.0	26.3	0.2	2.4	1.7
Initial Q Delay(d3), s/veh	0.0	0.0	0.0	0.0	0.0	0.0	0.0	0.0	0.0	0.0	0.0	0.0
%ile BackOfQ(95%),veh/ln	2.3	7.3	4.2	3.2	5.6	6.4	3.9	13.7	17.2	7.7	9.5	12.1
Unsig. Movement Delay, s/veh												
LnGrp Delay(d), s/veh	46.9	56.4	53.1	46.9	51.4	12.5	83.3	78.9	72.3	20.0	13.7	13.0
LnGrp LOS	D	E	D	D	D	B	F	E	E	B	B	B
Approach Vol, veh/h		257			293			602			1209	
Approach Delay, s/veh		53.6			34.3			75.8			14.7	
Approach LOS		D			C			E			B	
Timer - Assigned Phs	1	2	3	4	5	6	7	8				
Phs Duration (G+Y+Rc), s	61.6	30.4	10.0	17.9	9.8	82.2	8.6	19.4				
Change Period (Y+Rc), s	4.5	4.5	4.5	4.5	4.5	4.5	4.5	4.5				
Max Green Setting (Gmax), s	18.9	43.5	16.1	23.5	23.5	38.9	16.1	23.5				
Max Q Clear Time (g_c+I1), s	13.4	23.9	6.2	10.8	6.1	22.9	5.1	8.9				
Green Ext Time (p_c), s	0.4	2.0	0.1	0.6	0.1	3.7	0.1	0.8				
Intersection Summary												
HCM 7th Control Delay, s/veh			37.0									
HCM 7th LOS			D									

Intersection						
Int Delay, s/veh	0.1					
Movement	EBL	EBT	WBT	WBR	SBL	SBR
Lane Configurations	↘	↗	↗	↘	↘	↘
Traffic Vol, veh/h	0	1027	545	1	2	4
Future Vol, veh/h	0	1027	545	1	2	4
Conflicting Peds, #/hr	4	0	0	4	4	4
Sign Control	Free	Free	Free	Free	Stop	Stop
RT Channelized	-	None	-	None	-	None
Storage Length	105	-	-	55	60	0
Veh in Median Storage, #	-	0	0	-	0	-
Grade, %	-	0	0	-	0	-
Peak Hour Factor	100	100	100	100	100	100
Heavy Vehicles, %	1	8	6	1	1	1
Mvmt Flow	0	1027	545	1	2	4

Major/Minor	Major1	Major2	Minor2		
Conflicting Flow All	550	0	-	0	1580 553
Stage 1	-	-	-	-	549 -
Stage 2	-	-	-	-	1031 -
Critical Hdwy	4.11	-	-	-	6.41 6.21
Critical Hdwy Stg 1	-	-	-	-	5.41 -
Critical Hdwy Stg 2	-	-	-	-	5.41 -
Follow-up Hdwy	2.209	-	-	-	3.509 3.309
Pot Cap-1 Maneuver	1025	-	-	-	121 535
Stage 1	-	-	-	-	581 -
Stage 2	-	-	-	-	345 -
Platoon blocked, %		-	-	-	
Mov Cap-1 Maneuver	1021	-	-	-	120 531
Mov Cap-2 Maneuver	-	-	-	-	120 -
Stage 1	-	-	-	-	579 -
Stage 2	-	-	-	-	344 -

Approach	EB	WB	SB
HCM Ctrl Dly, s/v	0	0	19.73
HCM LOS			C

Minor Lane/Major Mvmt	EBL	EBT	WBT	WBR	SBLn1	SBLn2
Capacity (veh/h)	1021	-	-	-	120	531
HCM Lane V/C Ratio	-	-	-	-	0.017	0.008
HCM Ctrl Dly (s/v)	0	-	-	-	35.5	11.8
HCM Lane LOS	A	-	-	-	E	B
HCM 95th %tile Q(veh)	0	-	-	-	0.1	0

MOVEMENT SUMMARY

 Site: [99 (7)] SR 305 & Johnson Rd - Forecast 2037 AM
Without (AM Peak Hour)

Output produced by SIDRA INTERSECTION Version: 10.0.5.217

New Site
Site Category: (None)
Roundabout
Site Scenario: 1 | Local Volumes

Vehicle Movement Performance															
Mov ID	Turn	Mov Class	Demand Flows		Arrival Flows		Deg. Satn	Aver. Delay	Level of Service	95% Back Of Queue		Prop. Qued	Eff. Stop Rate	Number of Cycles to Depart	Aver. Speed
			[Total HV]	[Total HV]	[Total HV]	[Total HV]	v/c	sec		[Veh.]	[Dist]				mph
			veh/h	%	veh/h	%				veh	ft				
South: Johnson Way															
3u	U	All MCs	1	1.0	1	1.0	0.057	16.3	LOS B	0.2	6.2	0.67	0.80	0.67	30.5
3	L2	All MCs	21	1.0	21	1.0	0.057	12.8	LOS B	0.2	6.2	0.67	0.80	0.67	32.3
8	T1	All MCs	8	1.0	8	1.0	0.057	7.2	LOS A	0.2	6.2	0.67	0.80	0.67	29.8
18	R2	All MCs	4	1.0	4	1.0	0.057	12.7	LOS B	0.2	6.2	0.67	0.80	0.67	32.7
Approach			34	1.0	34	1.0	0.057	11.6	LOS B	0.2	6.2	0.67	0.80	0.67	31.6
East: SR 305															
1u	U	All MCs	1	1.0	1	1.0	0.264	12.0	LOS B	1.6	42.8	0.19	0.46	0.19	37.6
1	L2	All MCs	8	1.0	8	1.0	0.264	11.5	LOS B	1.6	42.8	0.19	0.46	0.19	35.7
6	T1	All MCs	513	6.0	513	6.0	0.264	6.1	LOS A	1.6	42.8	0.19	0.46	0.19	40.7
16	R2	All MCs	17	1.0	17	1.0	0.120	5.8	LOS A	0.6	16.4	0.18	0.47	0.18	36.1
Approach			539	5.8	539	5.8	0.264	6.2	LOS A	1.6	42.8	0.19	0.46	0.19	40.4
North: Johnson Rd															
7u	U	All MCs	1	1.0	1	1.0	0.142	13.9	LOS B	0.5	13.8	0.48	0.70	0.48	31.0
7	L2	All MCs	100	3.0	100	3.0	0.142	10.6	LOS B	0.5	13.8	0.48	0.70	0.48	32.6
4	T1	All MCs	2	1.0	2	1.0	0.142	4.8	LOS A	0.5	13.8	0.48	0.70	0.48	30.3
14	R2	All MCs	19	1.0	19	1.0	0.142	6.2	LOS A	0.5	13.8	0.48	0.70	0.48	33.2
Approach			122	2.6	122	2.6	0.142	9.9	LOS A	0.5	13.8	0.48	0.70	0.48	32.6
West: SR 305															
5u	U	All MCs	1	1.0	1	1.0	0.550	12.5	LOS B	4.7	125.4	0.43	0.49	0.43	36.8
5	L2	All MCs	12	17.0	12	17.0	0.550	12.5	LOS B	4.7	125.4	0.43	0.49	0.43	34.4
2	T1	All MCs	998	8.0	998	8.0	0.550	7.7	LOS A	4.7	125.4	0.41	0.49	0.41	39.5
12	R2	All MCs	23	12.0	23	12.0	0.250	6.6	LOS A	1.5	39.0	0.34	0.49	0.34	35.5
Approach			1034	8.2	1034	8.2	0.550	7.7	LOS A	4.7	125.4	0.41	0.49	0.41	39.3
All Vehicles			1729	6.9	1729	6.9	0.550	7.5	LOS A	4.7	125.4	0.35	0.50	0.35	38.9

Site Level of Service (LOS) Method: Delay & Degree of Saturation (SIDRA). Site LOS Method is specified in the Parameter Settings dialog (Options tab).

Roundabout LOS Method: Same as Signalised Intersections.

Vehicle movement LOS values are based on average delay and v/c ratio (degree of saturation) per movement.

Intersection and Approach LOS values are based on average delay for all movements (v/c not used).

Roundabout Capacity Model: SIDRA HCM.

Delay Model: SIDRA Standard (Control Delay: Geometric Delay is included).

Queue Model: SIDRA queue estimation methods are used for Back of Queue and Queue at Start of Gap.

Gap-Acceptance Capacity Formula: SIDRA Standard (Akçelik M3D).

HV (%) values are calculated for All Movement Classes of All Heavy Vehicle Model Designation.

Arrival Flows used in performance calculations are adjusted to include any Initial Queued Demand and Upstream Capacity Constraint effects.

SITE LAYOUT

 Site: [99 (7)] SR 305 & Johnson Rd - Forecast 2037 AM
Without (AM Peak Hour)

New Site
Site Category: (None)
Roundabout
Site Scenario: 1 | Local Volumes

Layout pictures are schematic functional drawings reflecting input data. They are not design drawings.

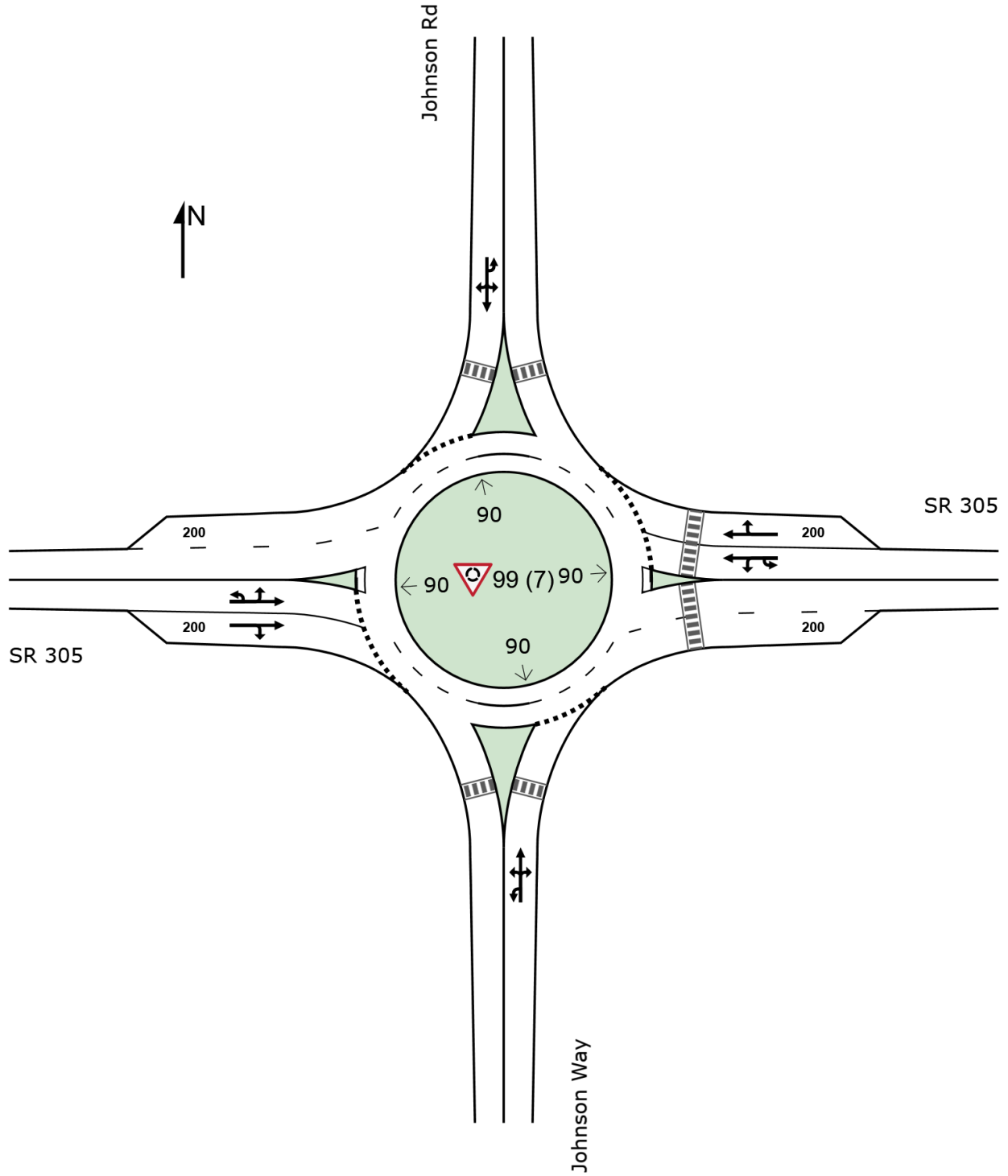

MOVEMENT SUMMARY

 Site: [1 (7)] Johnson & Sunrise Ridge - 2037 AM Without (Folder1)

Output produced by SIDRA INTERSECTION Version: 10.0.5.217

New Site
 Site Category: (None)
 Roundabout
 Site Scenario: 1 | Local Volumes

Vehicle Movement Performance															
Mov ID	Turn	Mov Class	Demand Flows		Arrival Flows		Deg. Satn	Aver. Delay	Level of Service	95% Back Of Queue		Prop. Qued	Eff. Stop Rate	Number of Cycles to Depart	Aver. Speed
			[Total HV]	[Total HV]	[Total HV]	[Total HV]	v/c	sec		[Veh.]	[Dist]				mph
			veh/h	%	veh/h	%				veh	ft				
South: NE Midnight Sun Loop															
3u	U	All MCs	1	3.0	1	3.0	0.004	7.2	LOSA	0.0	0.4	0.17	0.45	0.17	23.5
3	L2	All MCs	1	3.0	1	3.0	0.004	5.8	LOSA	0.0	0.4	0.17	0.45	0.17	23.5
8	T1	All MCs	1	3.0	1	3.0	0.004	2.0	LOSA	0.0	0.4	0.17	0.45	0.17	23.7
18	R2	All MCs	1	3.0	1	3.0	0.004	2.4	LOSA	0.0	0.4	0.17	0.45	0.17	23.6
Approach			5	3.0	5	3.0	0.004	4.3	LOSA	0.0	0.4	0.17	0.45	0.17	23.6
East: Johnson Rd NE															
1u	U	All MCs	1	3.0	1	3.0	0.088	10.9	LOS B	0.4	9.5	0.09	0.46	0.09	34.7
1	L2	All MCs	1	3.0	1	3.0	0.088	8.9	LOSA	0.4	9.5	0.09	0.46	0.09	34.7
6	T1	All MCs	110	3.0	110	3.0	0.088	4.9	LOSA	0.4	9.5	0.09	0.46	0.09	35.3
16	R2	All MCs	5	3.0	5	3.0	0.088	4.7	LOSA	0.4	9.5	0.09	0.46	0.09	35.0
Approach			117	3.0	117	3.0	0.088	5.0	LOSA	0.4	9.5	0.09	0.46	0.09	35.3
North: Sunrise Ridge Ave NE															
7u	U	All MCs	1	3.0	1	3.0	0.052	11.3	LOS B	0.2	5.5	0.24	0.56	0.24	34.0
7	L2	All MCs	14	3.0	14	3.0	0.052	9.4	LOSA	0.2	5.5	0.24	0.56	0.24	34.0
4	T1	All MCs	1	3.0	1	3.0	0.052	5.3	LOSA	0.2	5.5	0.24	0.56	0.24	34.6
14	R2	All MCs	43	3.0	43	3.0	0.052	5.1	LOSA	0.2	5.5	0.24	0.56	0.24	34.3
Approach			60	3.0	60	3.0	0.052	6.2	LOSA	0.2	5.5	0.24	0.56	0.24	34.2
West: Johnson Rd NE															
5u	U	All MCs	1	3.0	1	3.0	0.048	10.9	LOS B	0.2	5.2	0.09	0.53	0.09	34.2
5	L2	All MCs	14	3.0	14	3.0	0.048	9.0	LOSA	0.2	5.2	0.09	0.53	0.09	34.2
2	T1	All MCs	33	3.0	33	3.0	0.048	4.9	LOSA	0.2	5.2	0.09	0.53	0.09	34.9
12	R2	All MCs	12	3.0	12	3.0	0.048	4.7	LOSA	0.2	5.2	0.09	0.53	0.09	34.6
Approach			61	3.0	61	3.0	0.048	5.9	LOSA	0.2	5.2	0.09	0.53	0.09	34.6
All Vehicles			242	3.0	242	3.0	0.088	5.5	LOSA	0.4	9.5	0.13	0.50	0.13	34.5

Site Level of Service (LOS) Method: Delay & Degree of Saturation (SIDRA). Site LOS Method is specified in the Parameter Settings dialog (Options tab).

Roundabout LOS Method: Same as Signalised Intersections.

Vehicle movement LOS values are based on average delay and v/c ratio (degree of saturation) per movement.

Intersection and Approach LOS values are based on average delay for all movements (v/c not used).

Roundabout Capacity Model: SIDRA HCM.

Delay Model: SIDRA Standard (Control Delay: Geometric Delay is included).

Queue Model: SIDRA queue estimation methods are used for Back of Queue and Queue at Start of Gap.

Gap-Acceptance Capacity Formula: SIDRA Standard (Akçelik M3D).

HV (%) values are calculated for All Movement Classes of All Heavy Vehicle Model Designation.

Arrival Flows used in performance calculations are adjusted to include any Initial Queued Demand and Upstream Capacity Constraint effects.

SITE LAYOUT

 Site: [1 (7)] Johnson & Sunrise Ridge - 2037 AM Without (Folder1)

New Site
Site Category: (None)
Roundabout
Site Scenario: 1 | Local Volumes

Layout pictures are schematic functional drawings reflecting input data. They are not design drawings.

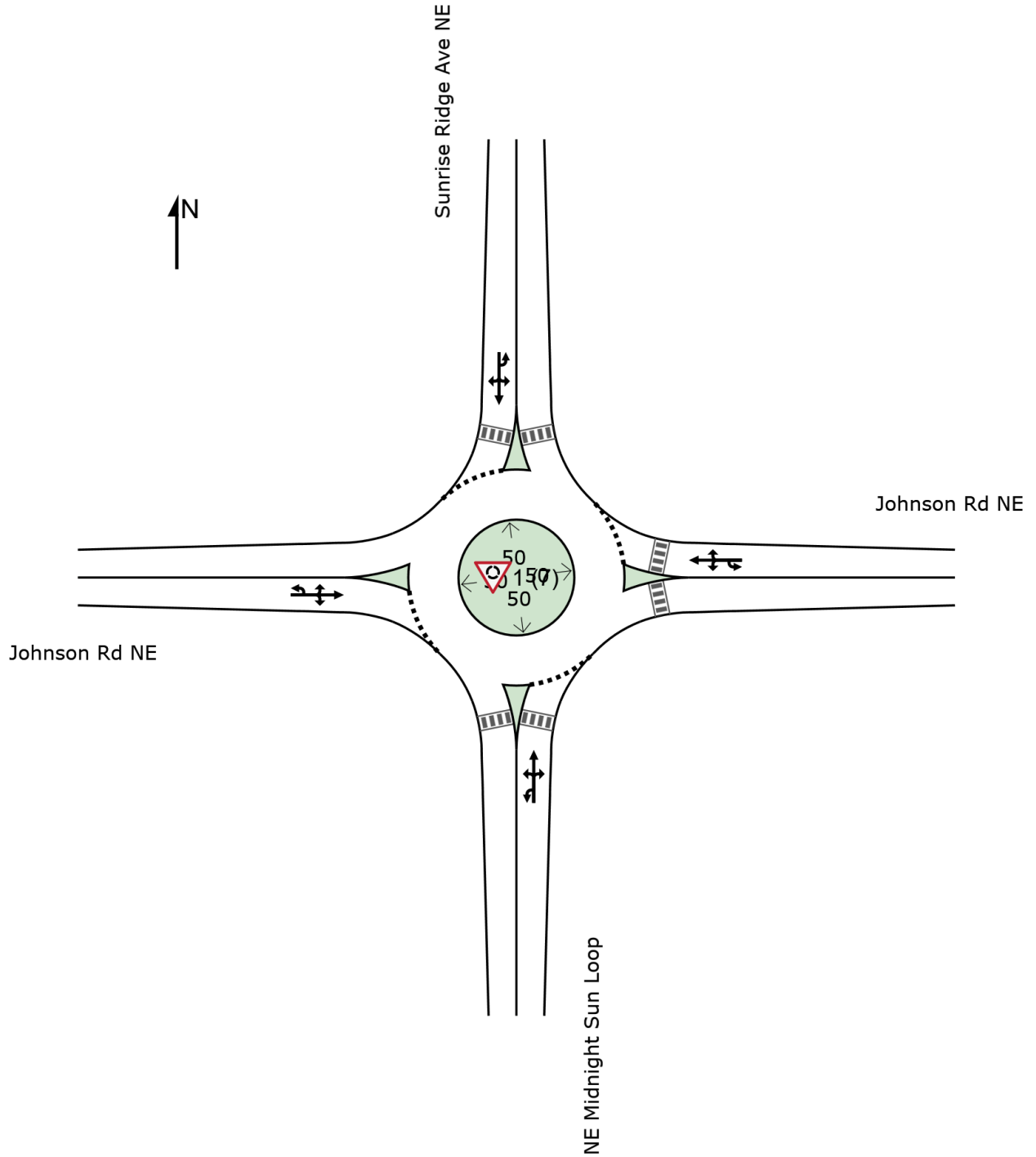

Intersection	
Intersection Delay, s/veh	61.9
Intersection LOS	F

Movement	EBL	EBT	EBR	WBL	WBT	WBR	NBL	NBT	NBR	SBL	SBT	SBR
Lane Configurations		↕			↕			↕			↕	↕
Traffic Vol, veh/h	58	285	28	25	257	97	73	45	49	157	31	73
Future Vol, veh/h	58	285	28	25	257	97	73	45	49	157	31	73
Peak Hour Factor	0.75	0.75	0.75	0.75	0.75	0.75	0.87	0.75	0.75	0.75	0.75	0.75
Heavy Vehicles, %	1	6	5	1	7	1	1	3	6	7	1	4
Mvmt Flow	77	380	37	33	343	129	84	60	65	209	41	97
Number of Lanes	0	1	0	0	1	0	0	1	0	0	1	1

Approach	EB	WB	NB	SB
Opposing Approach	WB	EB	SB	NB
Opposing Lanes	1	1	2	1
Conflicting Approach Left	SB	NB	EB	WB
Conflicting Lanes Left	2	1	1	1
Conflicting Approach Right	NB	SB	WB	EB
Conflicting Lanes Right	1	2	1	1
HCM Control Delay, s/veh	80.8	86.4	21.8	23.7
HCM LOS	F	F	C	C

Lane	NBLn1	EBLn1	WBLn1	SBLn1	SBLn2
Vol Left, %	44%	16%	7%	84%	0%
Vol Thru, %	27%	77%	68%	16%	0%
Vol Right, %	29%	8%	26%	0%	100%
Sign Control	Stop	Stop	Stop	Stop	Stop
Traffic Vol by Lane	167	371	379	188	73
LT Vol	73	58	25	157	0
Through Vol	45	285	257	31	0
RT Vol	49	28	97	0	73
Lane Flow Rate	209	495	505	251	97
Geometry Grp	4a	2	2	5	5
Degree of Util (X)	0.514	1.038	1.06	0.639	0.215
Departure Headway (Hd)	9.321	7.891	7.722	9.592	8.321
Convergence, Y/N	Yes	Yes	Yes	Yes	Yes
Cap	389	465	475	379	434
Service Time	7.321	5.891	5.722	7.292	6.021
HCM Lane V/C Ratio	0.537	1.065	1.063	0.662	0.224
HCM Control Delay, s/veh	21.8	80.8	86.4	27.8	13.3
HCM Lane LOS	C	F	F	D	B
HCM 95th-tile Q	2.8	14.5	15.5	4.2	0.8

Intersection						
Int Delay, s/veh	4					
Movement	EBT	EBR	WBL	WBT	NBL	NBR
Lane Configurations						
Traffic Vol, veh/h	41	40	7	69	70	28
Future Vol, veh/h	41	40	7	69	70	28
Conflicting Peds, /hr	0	10	10	0	10	10
Sign Control	Free	Free	Free	Free	Stop	Stop
RT Channelled	-	None	-	None	-	None
Storage Length	-	-	-	-	0	-
Veh in Median Storage, /	0	-	-	0	0	-
Grade, %	0	-	-	0	0	-
Peak Hour Factor	92	92	92	92	92	92
Heavy Vehicles, %	2	2	2	2	2	2
Mvmt Flow	45	43	8	75	76	30

























Major/Minor	Major1	Major2	Minor1			
Conflicting Flow All	0	0	98	0	177	86
Stage 1	-	-	-	-	76	-
Stage 2	-	-	-	-	100	-
Critical Hdwy	-	-	4.12	-	6.42	6.22
Critical Hdwy Stg 1	-	-	-	-	5.42	-
Critical Hdwy Stg 2	-	-	-	-	5.42	-
Follow-up Hdwy	-	-	2.218	-	3.518	3.318
Pot Cap-1 Maneuver	-	-	1495	-	813	972
Stage 1	-	-	-	-	947	-
Stage 2	-	-	-	-	924	-
Platoon blocked, %	-	-	-	-	-	-
Mov Cap-1 Maneuver	-	-	1483	-	795	956
Mov Cap-2 Maneuver	-	-	-	-	795	-
Stage 1	-	-	-	-	939	-
Stage 2	-	-	-	-	911	-

Approach	EB	WB	NB
HCM Ctrl Dly, s/v	0	0.69	9.94
HCM LOS			A

Minor Lane/Major Mvmt	NBLn1	EBT	EBR	WBL	WBT
Capacity (veh/h)	836	-	-	166	-
HCM Lane V/C Ratio	0.127	-	-	0.005	-
HCM Ctrl Dly (s/v)	9.9	-	-	7.4	0
HCM Lane LOS	A	-	-	A	A
HCM 95th %tile Q(veh)	0.4	-	-	0	-

HCM 7th Signalized Intersection Summary
1: SR305 & NE Hostmark St

Forecast 2037 PM Peak Hour
Without Project

												
Movement	EBL	EBT	EBR	WBL	WBT	WBR	NBL	NBT	NBR	SBL	SBT	SBR
Lane Configurations												
Traffic Volume (veh/h)	86	212	123	66	156	277	149	865	43	266	699	62
Future Volume (veh/h)	86	212	123	66	156	277	149	865	43	266	699	62
Initial Q (Qb), veh	0	0	0	0	0	0	0	0	0	0	0	0
Lane Width Adj.	1.00	1.00	1.00	1.00	1.00	1.00	1.00	1.00	1.00	1.00	1.00	1.00
Ped-Bike Adj(A_pbT)	0.99		0.97	0.99		0.96	1.00		0.96	1.00		0.97
Parking Bus, Adj	1.00	1.00	1.00	1.00	1.00	1.00	1.00	1.00	1.00	1.00	1.00	1.00
Work Zone On Approach		No			No			No			No	
Adj Sat Flow, veh/h/ln	1702	1758	1786	1786	1786	1786	1772	1744	1786	1786	1772	1744
Adj Flow Rate, veh/h	86	212	123	66	156	132	149	865	43	266	699	62
Peak Hour Factor	1.00	1.00	1.00	1.00	1.00	1.00	1.00	1.00	1.00	1.00	1.00	1.00
Percent Heavy Veh, %	7	3	1	1	1	1	2	4	1	1	2	4
Cap, veh/h	196	249	207	155	227	185	171	922	46	548	1501	133
Arrive On Green	0.06	0.14	0.14	0.04	0.13	0.13	0.10	0.33	0.33	0.32	0.55	0.55
Sat Flow, veh/h	1621	1758	1463	1701	1786	1459	1688	2811	140	1701	2735	242
Grp Volume(v), veh/h	86	212	123	66	156	132	149	381	527	266	321	440
Grp Sat Flow(s),veh/h/ln	1621	1758	1463	1701	1786	1459	1688	1238	1713	1701	1258	1720
Q Serve(g_s), s	5.5	14.1	9.5	4.0	10.0	5.7	10.4	35.8	35.9	15.1	18.6	18.6
Cycle Q Clear(g_c), s	5.5	14.1	9.5	4.0	10.0	5.7	10.4	35.8	35.9	15.1	18.6	18.6
Prop In Lane	1.00		1.00	1.00		1.00	1.00		0.08	1.00		0.14
Lane Grp Cap(c), veh/h	196	249	207	155	227	185	171	406	562	548	690	944
V/C Ratio(X)	0.44	0.85	0.59	0.42	0.69	0.71	0.87	0.94	0.94	0.48	0.47	0.47
Avail Cap(c_a), veh/h	316	337	280	306	342	280	323	444	614	548	690	944
HCM Platoon Ratio	1.00	1.00	1.00	1.00	1.00	1.00	1.00	1.00	1.00	1.00	1.00	1.00
Upstream Filter(I)	1.00	1.00	1.00	1.00	1.00	1.00	1.00	1.00	1.00	1.00	1.00	1.00
Uniform Delay (d), s/veh	42.8	50.3	48.3	43.8	50.1	14.9	53.1	39.1	39.2	32.7	16.4	16.4
Incr Delay (d2), s/veh	1.5	14.3	2.7	1.8	3.7	5.0	12.4	31.6	25.5	0.7	2.2	1.7
Initial Q Delay(d3), s/veh	0.0	0.0	0.0	0.0	0.0	0.0	0.0	0.0	0.0	0.0	0.0	0.0
%ile BackOfQ(95%),veh/ln	4.1	11.6	6.5	3.2	8.3	7.0	8.6	20.2	25.5	10.3	9.3	11.8
Unsig. Movement Delay, s/veh												
LnGrp Delay(d), s/veh	44.3	64.5	51.0	45.7	53.8	19.9	65.6	70.7	64.6	33.3	18.7	18.1
LnGrp LOS	D	E	D	D	D	B	E	E	E	C	B	B
Approach Vol, veh/h		421			354			1057			1027	
Approach Delay, s/veh		56.4			39.6			67.0			22.2	
Approach LOS		E			D			E			C	
Timer - Assigned Phs	1	2	3	4	5	6	7	8				
Phs Duration (G+Y+Rc), s	43.7	44.3	10.0	22.0	17.2	70.9	11.7	20.3				
Change Period (Y+Rc), s	4.5	4.5	4.5	4.5	4.5	4.5	4.5	4.5				
Max Green Setting (Gmax), s	18.9	43.5	16.1	23.5	23.5	38.9	16.1	23.5				
Max Q Clear Time (g_c+I1), s	17.1	37.9	6.0	16.1	12.4	20.6	7.5	12.0				
Green Ext Time (p_c), s	0.2	2.0	0.1	0.8	0.3	2.9	0.1	0.9				
Intersection Summary												
HCM 7th Control Delay, s/veh			45.9									
HCM 7th LOS			D									

Intersection						
Int Delay, s/veh	0.1					
Movement	EBL	EBT	WBT	WBR	SBL	SBR
Lane Configurations	↖	↗	↗	↖	↖	↖
Traffic Vol, veh/h	7	833	966	6	1	4
Future Vol, veh/h	7	833	966	6	1	4
Conflicting Peds, #/hr	1	0	0	1	1	1
Sign Control	Free	Free	Free	Free	Stop	Stop
RT Channelized	-	None	-	None	-	None
Storage Length	105	-	-	55	60	0
Veh in Median Storage, #	-	0	0	-	0	-
Grade, %	-	0	0	-	0	-
Peak Hour Factor	100	100	100	100	100	100
Heavy Vehicles, %	10	2	3	1	10	1
Mvmt Flow	7	833	966	6	1	4

Major/Minor	Major1	Major2	Minor2		
Conflicting Flow All	973	0	-	0	1815 968
Stage 1	-	-	-	-	967 -
Stage 2	-	-	-	-	848 -
Critical Hdwy	4.2	-	-	-	6.5 6.21
Critical Hdwy Stg 1	-	-	-	-	5.5 -
Critical Hdwy Stg 2	-	-	-	-	5.5 -
Follow-up Hdwy	2.29	-	-	-	3.59 3.309
Pot Cap-1 Maneuver	678	-	-	-	82 309
Stage 1	-	-	-	-	357 -
Stage 2	-	-	-	-	407 -
Platoon blocked, %		-	-	-	
Mov Cap-1 Maneuver	677	-	-	-	81 309
Mov Cap-2 Maneuver	-	-	-	-	81 -
Stage 1	-	-	-	-	353 -
Stage 2	-	-	-	-	406 -

Approach	EB	WB	SB
HCM Ctrl Dly, s/v	0.09	0	23.46
HCM LOS			C

Minor Lane/Major Mvmt	EBL	EBT	WBT	WBR	SBLn1	SBLn2
Capacity (veh/h)	677	-	-	-	81	309
HCM Lane V/C Ratio	0.01	-	-	-	0.012	0.013
HCM Ctrl Dly (s/v)	10.4	-	-	-	50	16.8
HCM Lane LOS	B	-	-	-	F	C
HCM 95th %tile Q(veh)	0	-	-	-	0	0

MOVEMENT SUMMARY

 Site: [99 (9)] SR 305 & Johnson Rd - Forecast 2037 Without (PM Peak Hour)

Output produced by SIDRA INTERSECTION Version: 10.0.5.217

New Site
 Site Category: (None)
 Roundabout
Site Scenario: 1 | Local Volumes

Vehicle Movement Performance															
Mov ID	Turn	Mov Class	Demand Flows		Arrival Flows		Deg. Satn	Aver. Delay	Level of Service	95% Back Of Queue		Prop. Qued	Eff. Stop Rate	Number of Cycles to Depart	Aver. Speed
			[Total HV]	[Total HV]	[Total HV]	[Total HV]	v/c	sec		[Veh.]	[Dist]				mph
			veh/h	%	veh/h	%				veh	ft				
South: Johnson Way															
3u	U	All MCs	1	1.0	1	1.0	0.060	14.7	LOS B	0.2	5.8	0.55	0.73	0.55	31.2
3	L2	All MCs	25	6.0	25	6.0	0.060	11.7	LOS B	0.2	5.8	0.55	0.73	0.55	32.3
8	T1	All MCs	7	1.0	7	1.0	0.060	5.7	LOS A	0.2	5.8	0.55	0.73	0.55	30.4
18	R2	All MCs	10	1.0	10	1.0	0.060	7.8	LOS A	0.2	5.8	0.55	0.73	0.55	33.4
Approach			43	3.9	43	3.9	0.060	9.9	LOS A	0.2	5.8	0.55	0.73	0.55	32.2
East: SR 305															
1u	U	All MCs	3	1.0	3	1.0	0.465	12.1	LOS B	3.7	93.8	0.24	0.46	0.24	37.5
1	L2	All MCs	13	1.0	13	1.0	0.465	11.5	LOS B	3.7	93.8	0.24	0.46	0.24	35.6
6	T1	All MCs	934	3.0	934	3.0	0.465	6.5	LOS A	3.7	93.8	0.23	0.46	0.23	41.0
16	R2	All MCs	27	10.0	27	10.0	0.211	6.0	LOS A	1.2	31.2	0.20	0.46	0.20	35.9
Approach			977	3.2	977	3.2	0.465	6.5	LOS A	3.7	93.8	0.23	0.46	0.23	40.8
North: Johnson Rd															
7u	U	All MCs	1	1.0	1	1.0	0.081	15.3	LOS B	0.3	8.1	0.59	0.77	0.59	30.7
7	L2	All MCs	34	6.0	34	6.0	0.081	12.4	LOS B	0.3	8.1	0.59	0.77	0.59	31.9
4	T1	All MCs	4	1.0	4	1.0	0.081	6.3	LOS A	0.3	8.1	0.59	0.77	0.59	30.0
14	R2	All MCs	15	1.0	15	1.0	0.081	9.1	LOS A	0.3	8.1	0.59	0.77	0.59	33.0
Approach			54	4.1	54	4.1	0.081	11.1	LOS B	0.3	8.1	0.59	0.77	0.59	32.0
West: SR 305															
5u	U	All MCs	1	1.0	1	1.0	0.399	12.1	LOS B	2.9	73.1	0.24	0.46	0.24	37.5
5	L2	All MCs	11	1.0	11	1.0	0.399	11.5	LOS B	2.9	73.1	0.24	0.46	0.24	35.5
2	T1	All MCs	804	2.0	804	2.0	0.399	6.3	LOS A	2.9	73.1	0.24	0.46	0.24	41.2
12	R2	All MCs	25	1.0	25	1.0	0.181	5.9	LOS A	1.0	25.6	0.22	0.47	0.22	36.0
Approach			841	2.0	841	2.0	0.399	6.4	LOS A	2.9	73.1	0.23	0.46	0.23	40.9
All Vehicles			1915	2.7	1915	2.7	0.465	6.7	LOS A	3.7	93.8	0.25	0.47	0.25	40.3

Site Level of Service (LOS) Method: Delay & Degree of Saturation (SIDRA). Site LOS Method is specified in the Parameter Settings dialog (Options tab).

Roundabout LOS Method: Same as Signalised Intersections.

Vehicle movement LOS values are based on average delay and v/c ratio (degree of saturation) per movement.

Intersection and Approach LOS values are based on average delay for all movements (v/c not used).

Roundabout Capacity Model: SIDRA HCM.

Delay Model: SIDRA Standard (Control Delay: Geometric Delay is included).

Queue Model: SIDRA queue estimation methods are used for Back of Queue and Queue at Start of Gap.

Gap-Acceptance Capacity Formula: SIDRA Standard (Akçelik M3D).

HV (%) values are calculated for All Movement Classes of All Heavy Vehicle Model Designation.

Arrival Flows used in performance calculations are adjusted to include any Initial Queued Demand and Upstream Capacity Constraint effects.

SITE LAYOUT

 Site: [99 (9)] SR 305 & Johnson Rd - Forecast 2037 Without
(PM Peak Hour)

New Site
Site Category: (None)
Roundabout
Site Scenario: 1 | Local Volumes

Layout pictures are schematic functional drawings reflecting input data. They are not design drawings.

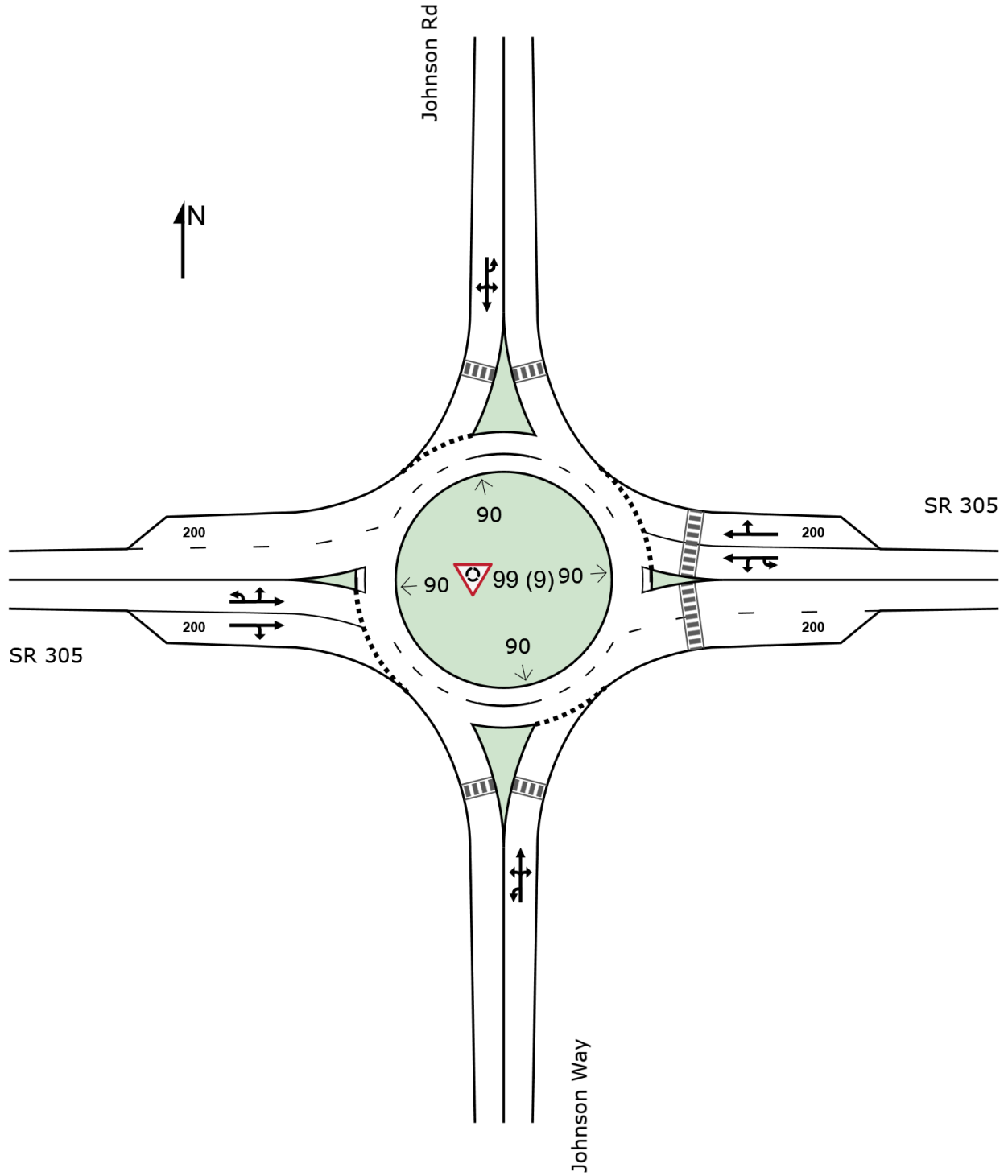

MOVEMENT SUMMARY

 Site: [1 (9)] Johnson & Sunrise Ridge - 2037 PM Without (Folder1)

Output produced by SIDRA INTERSECTION Version: 10.0.5.217

New Site
 Site Category: (None)
 Roundabout
 Site Scenario: 1 | Local Volumes

Vehicle Movement Performance															
Mov ID	Turn	Mov Class	Demand Flows		Arrival Flows		Deg. Satn	Aver. Delay	Level of Service	95% Back Of Queue		Prop. Qued	Eff. Stop of Cycles	Number of Cycles to Depart	Aver. Speed
			[Total HV]	[Total HV]	[Total HV]	[Total HV]	v/c	sec		[Veh.]	[Dist]		Rate		mph
			veh/h	%	veh/h	%				veh	ft				
South: NE Midnight Sun Loop															
3u	U	All MCs	1	3.0	1	3.0	0.006	7.2	LOSA	0.0	0.6	0.17	0.41	0.17	23.7
3	L2	All MCs	1	3.0	1	3.0	0.006	5.8	LOSA	0.0	0.6	0.17	0.41	0.17	23.7
8	T1	All MCs	1	3.0	1	3.0	0.006	2.0	LOSA	0.0	0.6	0.17	0.41	0.17	23.9
18	R2	All MCs	5	3.0	5	3.0	0.006	2.4	LOSA	0.0	0.6	0.17	0.41	0.17	23.8
Approach			8	3.0	8	3.0	0.006	3.5	LOSA	0.0	0.6	0.17	0.41	0.17	23.8
East: Johnson Rd NE															
1u	U	All MCs	1	3.0	1	3.0	0.052	10.9	LOS B	0.2	5.4	0.12	0.48	0.12	34.5
1	L2	All MCs	5	3.0	5	3.0	0.052	9.0	LOSA	0.2	5.4	0.12	0.48	0.12	34.5
6	T1	All MCs	50	3.0	50	3.0	0.052	5.0	LOSA	0.2	5.4	0.12	0.48	0.12	35.1
16	R2	All MCs	12	3.0	12	3.0	0.052	4.7	LOSA	0.2	5.4	0.12	0.48	0.12	34.8
Approach			68	3.0	68	3.0	0.052	5.3	LOSA	0.2	5.4	0.12	0.48	0.12	35.0
North: Sunrise Ridge Ave NE															
7u	U	All MCs	1	3.0	1	3.0	0.029	11.0	LOS B	0.1	3.0	0.16	0.55	0.16	34.2
7	L2	All MCs	7	3.0	7	3.0	0.029	9.1	LOSA	0.1	3.0	0.16	0.55	0.16	34.2
4	T1	All MCs	1	3.0	1	3.0	0.029	5.1	LOSA	0.1	3.0	0.16	0.55	0.16	34.8
14	R2	All MCs	26	3.0	26	3.0	0.029	4.8	LOSA	0.1	3.0	0.16	0.55	0.16	34.5
Approach			35	3.0	35	3.0	0.029	5.9	LOSA	0.1	3.0	0.16	0.55	0.16	34.5
West: Johnson Rd NE															
5u	U	All MCs	1	3.0	1	3.0	0.045	10.9	LOS B	0.2	4.8	0.08	0.58	0.08	33.7
5	L2	All MCs	30	3.0	30	3.0	0.045	8.9	LOSA	0.2	4.8	0.08	0.58	0.08	33.7
2	T1	All MCs	26	3.0	26	3.0	0.045	4.9	LOSA	0.2	4.8	0.08	0.58	0.08	34.3
12	R2	All MCs	1	3.0	1	3.0	0.045	4.6	LOSA	0.2	4.8	0.08	0.58	0.08	34.0
Approach			58	3.0	58	3.0	0.045	7.1	LOSA	0.2	4.8	0.08	0.58	0.08	34.0
All Vehicles			169	3.0	169	3.0	0.052	5.9	LOSA	0.2	5.4	0.12	0.53	0.12	33.8

Site Level of Service (LOS) Method: Delay & Degree of Saturation (SIDRA). Site LOS Method is specified in the Parameter Settings dialog (Options tab).

Roundabout LOS Method: Same as Signalised Intersections.

Vehicle movement LOS values are based on average delay and v/c ratio (degree of saturation) per movement.

Intersection and Approach LOS values are based on average delay for all movements (v/c not used).

Roundabout Capacity Model: SIDRA HCM.

Delay Model: SIDRA Standard (Control Delay: Geometric Delay is included).

Queue Model: SIDRA queue estimation methods are used for Back of Queue and Queue at Start of Gap.

Gap-Acceptance Capacity Formula: SIDRA Standard (Akçelik M3D).

HV (%) values are calculated for All Movement Classes of All Heavy Vehicle Model Designation.

Arrival Flows used in performance calculations are adjusted to include any Initial Queued Demand and Upstream Capacity Constraint effects.

SITE LAYOUT

 Site: [1 (9)] Johnson & Sunrise Ridge - 2037 PM Without (Folder1)

New Site
Site Category: (None)
Roundabout
Site Scenario: 1 | Local Volumes

Layout pictures are schematic functional drawings reflecting input data. They are not design drawings.

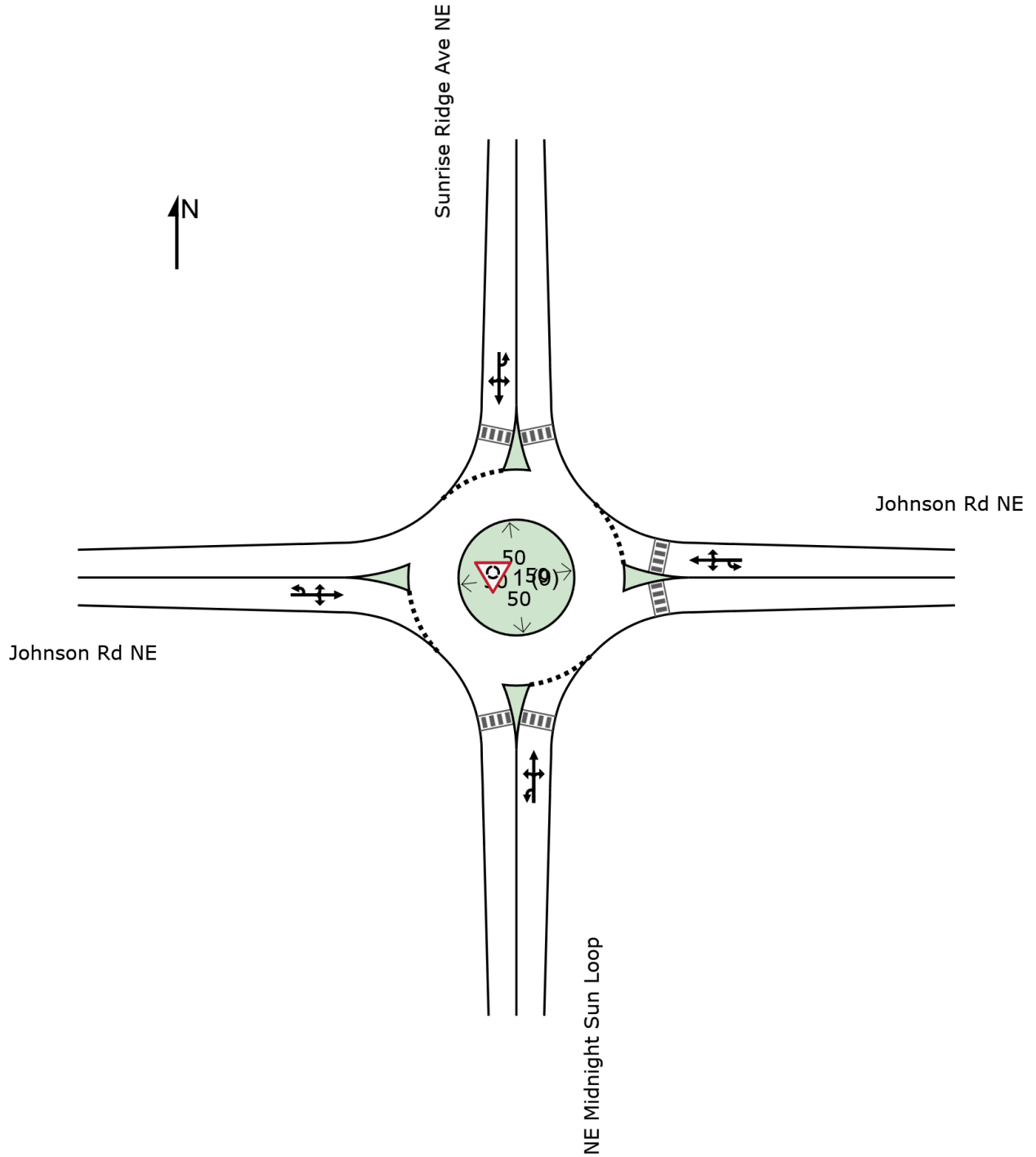

Intersection	
Intersection Delay, s/veh	26.1
Intersection LOS	D

Movement	EBL	EBT	EBR	WBL	WBT	WBR	NBL	NBT	NBR	SBL	SBT	SBR
Lane Configurations		↔			↔			↔			↔	↔
Traffic Vol, veh/h	108	264	87	11	166	60	78	60	3	111	75	79
Future Vol, veh/h	108	264	87	11	166	60	78	60	3	111	75	79
Peak Hour Factor	0.87	0.87	0.87	0.87	0.87	0.87	0.87	0.87	0.87	0.87	0.87	0.87
Heavy Vehicles, %	3	1	1	1	1	2	1	1	1	1	1	4
Mvmt Flow	124	303	100	13	191	69	90	69	3	128	86	91
Number of Lanes	0	1	0	0	1	0	0	1	0	0	1	1

Approach	EB	WB	NB	SB
Opposing Approach	WB	EB	SB	NB
Opposing Lanes	1	1	2	1
Conflicting Approach Left	SB	NB	EB	WB
Conflicting Lanes Left	2	1	1	1
Conflicting Approach Right	NB	SB	WB	EB
Conflicting Lanes Right	1	2	1	1
HCM Control Delay, s/veh	41.3	16	14.4	15.2
HCM LOS	E	C	B	C

Lane	NBLn1	EBLn1	WBLn1	SBLn1	SBLn2
Vol Left, %	55%	24%	5%	60%	0%
Vol Thru, %	43%	58%	70%	40%	0%
Vol Right, %	2%	19%	25%	0%	100%
Sign Control	Stop	Stop	Stop	Stop	Stop
Traffic Vol by Lane	141	459	237	186	79
LT Vol	78	108	11	111	0
Through Vol	60	264	166	75	0
RT Vol	3	87	60	0	79
Lane Flow Rate	162	528	272	214	91
Geometry Grp	4a	2	2	5	5
Degree of Util (U)	0.338	0.898	0.497	0.46	0.169
Departure Headway (Hd)	7.505	6.127	6.565	7.74	6.714
Convergence, U/N	les	les	les	les	les
Cap	476	591	545	464	531
Service Time	5.598	4.187	4.641	5.518	4.491
HCM Lane V/C Ratio	0.34	0.893	0.499	0.461	0.171
HCM Control Delay, s/veh	14.4	41.3	16	17	10.9
HCM Lane LOS	B	E	C	C	B
HCM 95th-tile Q	1.5	10.8	2.7	2.4	0.6

Intersection						
Int Delay, s/veh	3					
Movement	EBT	EBR	WBL	WBT	NBL	NBR
Lane Configurations						
Traffic Vol, veh/h	69	74	28	69	48	21
Future Vol, veh/h	69	74	28	69	48	21
Conflicting Peds, #/hr	0	10	10	0	10	10
Sign Control	Free	Free	Free	Free	Stop	Stop
RT Channelized	-	None	-	None	-	None
Storage Length	-	-	-	-	0	-
Veh in Median Storage, #	0	-	-	0	0	-
Grade, %	0	-	-	0	0	-
Peak Hour Factor	92	92	92	92	92	92
Heavy Vehicles, %	2	2	2	2	2	2
Mvmt Flow	75	80	30	75	52	23

Major/Minor	Major1	Major2	Minor1			
Conflicting Flow All	0	0	165	0	271	135
Stage 1	-	-	-	-	125	-
Stage 2	-	-	-	-	146	-
Critical Hdwy	-	-	4.12	-	6.42	6.22
Critical Hdwy Stg 1	-	-	-	-	5.42	-
Critical Hdwy Stg 2	-	-	-	-	5.42	-
Follow-up Hdwy	-	-	2.218	-	3.518	3.318
Pot Cap-1 Maneuver	-	-	1413	-	718	914
Stage 1	-	-	-	-	900	-
Stage 2	-	-	-	-	881	-
Platoon blocked, %	-	-	-	-	-	-
Mov Cap-1 Maneuver	-	-	1401	-	690	898
Mov Cap-2 Maneuver	-	-	-	-	690	-
Stage 1	-	-	-	-	893	-
Stage 2	-	-	-	-	854	-

Approach	EB	WB	NB
HCM Ctrl Dly, s/v	0	2.2	10.39
HCM LOS			B

Minor Lane/Major Mvmt	NBLn1	EBT	EBR	WBL	WBT
Capacity (veh/h)	743	-	-	520	-
HCM Lane V/C Ratio	0.101	-	-	0.022	-
HCM Ctrl Dly (s/v)	10.4	-	-	7.6	0
HCM Lane LOS	B	-	-	A	A
HCM 95th %tile Q(veh)	0.3	-	-	0.1	-

HCM 7th Signalized Intersection Summary
1: SR305 & NE Hostmark St

Forecast 2037 AM Peak Hour
With Project

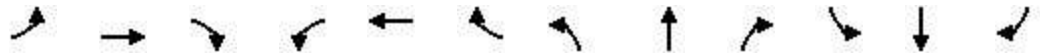

Movement	EBL	EBT	EBR	WBL	WBT	WBR	NBL	NBT	NBR	SBL	SBT	SBR
Lane Configurations												
Traffic Volume (veh/h)	47	131	84	65	107	181	71	537	26	252	939	25
Future Volume (veh/h)	47	131	84	65	107	181	71	537	26	252	939	25
Initial Q (Qb), veh	0	0	0	0	0	0	0	0	0	0	0	0
Lane Width Adj.	1.00	1.00	1.00	1.00	1.00	1.00	1.00	1.00	1.00	1.00	1.00	1.00
Ped-Bike Adj(A_pbT)	0.99		0.98	0.99		0.98	1.00		0.98	1.00		0.99
Parking Bus, Adj	1.00	1.00	1.00	1.00	1.00	1.00	1.00	1.00	1.00	1.00	1.00	1.00
Work Zone On Approach		No			No			No			No	
Adj Sat Flow, veh/h/ln	1716	1730	1744	1744	1744	1716	1730	1716	1716	1730	1716	1646
Adj Flow Rate, veh/h	47	131	84	65	107	121	71	537	26	252	939	25
Peak Hour Factor	1.00	1.00	1.00	1.00	1.00	1.00	1.00	1.00	1.00	1.00	1.00	1.00
Percent Heavy Veh, %	6	5	4	4	4	6	5	6	6	5	6	11
Cap, veh/h	178	187	156	169	210	171	84	604	29	767	1799	48
Arrive On Green	0.03	0.11	0.11	0.04	0.12	0.12	0.05	0.22	0.22	0.47	0.63	0.63
Sat Flow, veh/h	1634	1730	1445	1661	1744	1425	1647	2773	134	1647	2844	76
Grp Volume(v), veh/h	47	131	84	65	107	121	71	236	327	252	402	562
Grp Sat Flow(s),veh/h/ln	1634	1730	1445	1661	1744	1425	1647	1218	1689	1647	1218	1702
Q Serve(g_s), s	3.1	8.8	6.6	4.2	6.9	3.8	5.1	22.5	22.6	11.6	21.7	21.7
Cycle Q Clear(g_c), s	3.1	8.8	6.6	4.2	6.9	3.8	5.1	22.5	22.6	11.6	21.7	21.7
Prop In Lane	1.00		1.00	1.00		1.00	1.00		0.08	1.00		0.04
Lane Grp Cap(c), veh/h	178	187	156	169	210	171	84	265	368	767	771	1076
V/C Ratio(X)	0.26	0.70	0.54	0.38	0.51	0.71	0.85	0.89	0.89	0.33	0.52	0.52
Avail Cap(c_a), veh/h	342	332	277	316	334	273	316	437	605	767	771	1076
HCM Platoon Ratio	1.00	1.00	1.00	1.00	1.00	1.00	1.00	1.00	1.00	1.00	1.00	1.00
Upstream Filter(I)	1.00	1.00	1.00	1.00	1.00	1.00	1.00	1.00	1.00	1.00	1.00	1.00
Uniform Delay (d), s/veh	46.1	51.7	50.7	45.5	49.5	7.5	56.5	45.5	45.5	20.2	12.1	12.1
Incr Delay (d2), s/veh	0.8	4.7	2.9	1.4	1.9	5.2	20.0	32.7	26.1	0.2	2.5	1.8
Initial Q Delay(d3), s/veh	0.0	0.0	0.0	0.0	0.0	0.0	0.0	0.0	0.0	0.0	0.0	0.0
%ile BackOfQ(95%),veh/ln	2.3	7.3	4.5	3.2	5.6	6.4	4.6	14.0	17.6	7.8	9.9	12.6
Unsig. Movement Delay, s/veh												
LnGrp Delay(d), s/veh	46.9	56.4	53.6	46.9	51.4	12.8	76.5	78.2	71.6	20.5	14.6	13.9
LnGrp LOS	D	E	D	D	D	B	E	E	E	C	B	B
Approach Vol, veh/h		262			293			634			1216	
Approach Delay, s/veh		53.8			34.4			74.6			15.5	
Approach LOS		D			C			E			B	
Timer - Assigned Phs	1	2	3	4	5	6	7	8				
Phs Duration (G+Y+Rc), s	60.9	31.1	10.0	18.0	11.1	80.9	8.6	19.4				
Change Period (Y+Rc), s	4.5	4.5	4.5	4.5	4.5	4.5	4.5	4.5				
Max Green Setting (Gmax), s	18.9	43.5	16.1	23.5	23.5	38.9	16.1	23.5				
Max Q Clear Time (g_c+I1), s	13.6	24.6	6.2	10.8	7.1	23.7	5.1	8.9				
Green Ext Time (p_c), s	0.4	2.0	0.1	0.6	0.2	3.7	0.1	0.8				
Intersection Summary												
HCM 7th Control Delay, s/veh			37.6									
HCM 7th LOS			D									

Intersection						
Int Delay, s/veh	0.1					
Movement	EBL	EBT	WBT	WBR	SBL	SBR
Lane Configurations	↘	↗	↗	↘	↘	↘
Traffic Vol, veh/h	0	1039	577	1	2	4
Future Vol, veh/h	0	1039	577	1	2	4
Conflicting Peds, #/hr	4	0	0	4	4	4
Sign Control	Free	Free	Free	Free	Stop	Stop
RT Channelized	-	None	-	None	-	None
Storage Length	105	-	-	55	60	0
Veh in Median Storage, #	-	0	0	-	0	-
Grade, %	-	0	0	-	0	-
Peak Hour Factor	100	100	100	100	100	100
Heavy Vehicles, %	1	8	6	1	1	1
Mvmt Flow	0	1039	577	1	2	4

Major/Minor	Major1	Major2	Minor2		
Conflicting Flow All	582	0	-	0	1624 585
Stage 1	-	-	-	-	581 -
Stage 2	-	-	-	-	1043 -
Critical Hdwy	4.11	-	-	-	6.41 6.21
Critical Hdwy Stg 1	-	-	-	-	5.41 -
Critical Hdwy Stg 2	-	-	-	-	5.41 -
Follow-up Hdwy	2.209	-	-	-	3.509 3.309
Pot Cap-1 Maneuver	997	-	-	-	113 513
Stage 1	-	-	-	-	561 -
Stage 2	-	-	-	-	341 -
Platoon blocked, %	-	-	-	-	-
Mov Cap-1 Maneuver	994	-	-	-	113 509
Mov Cap-2 Maneuver	-	-	-	-	113 -
Stage 1	-	-	-	-	559 -
Stage 2	-	-	-	-	340 -

Approach	EB	WB	SB
HCM Ctrl Dly, s/v	0	0	20.59
HCM LOS			C

Minor Lane/Major Mvmt	EBL	EBT	WBT	WBR	SBLn1	SBLn2
Capacity (veh/h)	994	-	-	-	113	509
HCM Lane V/C Ratio	-	-	-	-	0.018	0.008
HCM Ctrl Dly (s/v)	0	-	-	-	37.5	12.1
HCM Lane LOS	A	-	-	-	E	B
HCM 95th %tile Q(veh)	0	-	-	-	0.1	0

MOVEMENT SUMMARY

 Site: [99 (8)] SR 305 & Johnson Rd - Forecast 2037 AM With (AM Peak Hour)

Output produced by SIDRA INTERSECTION Version: 10.0.9.250

New Site
 Site Category: (None)
 Roundabout
Site Scenario: 1 | Local Volumes

Vehicle Movement Performance															
Mov ID	Turn	Mov Class	Demand Flows		Arrival Flows		Deg. Satn	Aver. Delay	Level of Service	95% Back Of Queue		Prop. Qued	Eff. Stop of Cycles	Number of Cycles to Depart	Aver. Speed
			[Total HV]	[Total HV]	[Total HV]	[Total HV]	v/c	sec		[Veh.]	[Dist]		Rate		mph
			veh/h	%	veh/h	%				veh	ft				
South: Johnson Way															
3u	U	All MCs	1	1.0	1	1.0	0.060	16.6	LOS B	0.3	6.7	0.69	0.81	0.69	30.4
3	L2	All MCs	21	1.0	21	1.0	0.060	13.1	LOS B	0.3	6.7	0.69	0.81	0.69	32.1
8	T1	All MCs	8	1.0	8	1.0	0.060	7.5	LOS A	0.3	6.7	0.69	0.81	0.69	29.6
18	R2	All MCs	4	1.0	4	1.0	0.060	13.5	LOS B	0.3	6.7	0.69	0.81	0.69	32.5
Approach			34	1.0	34	1.0	0.060	12.0	LOS B	0.3	6.7	0.69	0.81	0.69	31.5
East: SR 305															
1u	U	All MCs	1	1.0	1	1.0	0.272	12.1	LOS B	1.6	42.9	0.21	0.46	0.21	37.5
1	L2	All MCs	8	1.0	8	1.0	0.272	11.5	LOS B	1.6	42.9	0.21	0.46	0.21	35.6
6	T1	All MCs	513	6.0	513	6.0	0.272	6.1	LOS A	1.6	42.9	0.21	0.47	0.21	40.6
16	R2	All MCs	27	1.0	27	1.0	0.124	5.9	LOS A	0.6	16.4	0.21	0.47	0.21	36.0
Approach			549	5.7	549	5.7	0.272	6.2	LOS A	1.6	42.9	0.21	0.47	0.21	40.2
North: Johnson Rd															
7u	U	All MCs	1	1.0	1	1.0	0.212	14.1	LOS B	0.9	21.8	0.50	0.70	0.50	31.2
7	L2	All MCs	128	3.0	128	3.0	0.212	10.8	LOS B	0.9	21.8	0.50	0.70	0.50	32.8
4	T1	All MCs	2	1.0	2	1.0	0.212	5.0	LOS A	0.9	21.8	0.50	0.70	0.50	30.4
14	R2	All MCs	51	1.0	51	1.0	0.212	6.4	LOS A	0.9	21.8	0.50	0.70	0.50	33.5
Approach			182	2.4	182	2.4	0.212	9.5	LOS A	0.9	21.8	0.50	0.70	0.50	33.0
West: SR 305															
5u	U	All MCs	1	1.0	1	1.0	0.572	12.7	LOS B	5.0	132.9	0.49	0.51	0.49	36.5
5	L2	All MCs	24	17.0	24	17.0	0.572	12.8	LOS B	5.0	132.9	0.49	0.51	0.49	34.2
2	T1	All MCs	998	8.0	998	8.0	0.572	8.0	LOS A	5.0	132.9	0.47	0.51	0.47	39.2
12	R2	All MCs	23	12.0	23	12.0	0.260	6.8	LOS A	1.5	40.7	0.38	0.51	0.38	35.3
Approach			1046	8.3	1046	8.3	0.572	8.1	LOS A	5.0	132.9	0.47	0.51	0.47	39.0
All Vehicles			1811	6.8	1811	6.8	0.572	7.8	LOS A	5.0	132.9	0.40	0.52	0.40	38.5

Site Level of Service (LOS) Method: Delay & Degree of Saturation (SIDRA). Site LOS Method is specified in the Parameter Settings dialog (Options tab).

Roundabout LOS Method: Same as Signalised Intersections.

Vehicle movement LOS values are based on average delay and v/c ratio (degree of saturation) per movement.

Intersection and Approach LOS values are based on average delay for all movements (v/c not used).

Roundabout Capacity Model: SIDRA HCM.

Delay Model: SIDRA Standard (Control Delay: Geometric Delay is included).

Queue Model: SIDRA queue estimation methods are used for Back of Queue and Queue at Start of Gap.

Gap-Acceptance Capacity Formula: SIDRA Standard (Akçelik M3D).

HV (%) values are calculated for All Movement Classes of All Heavy Vehicle Model Designation.

Arrival Flows used in performance calculations are adjusted to include any Initial Queued Demand and Upstream Capacity Constraint effects.

SITE LAYOUT

 Site: [99 (8)] SR 305 & Johnson Rd - Forecast 2037 AM With (AM Peak Hour)

New Site
Site Category: (None)
Roundabout
Site Scenario: 1 | Local Volumes

Layout pictures are schematic functional drawings reflecting input data. They are not design drawings.

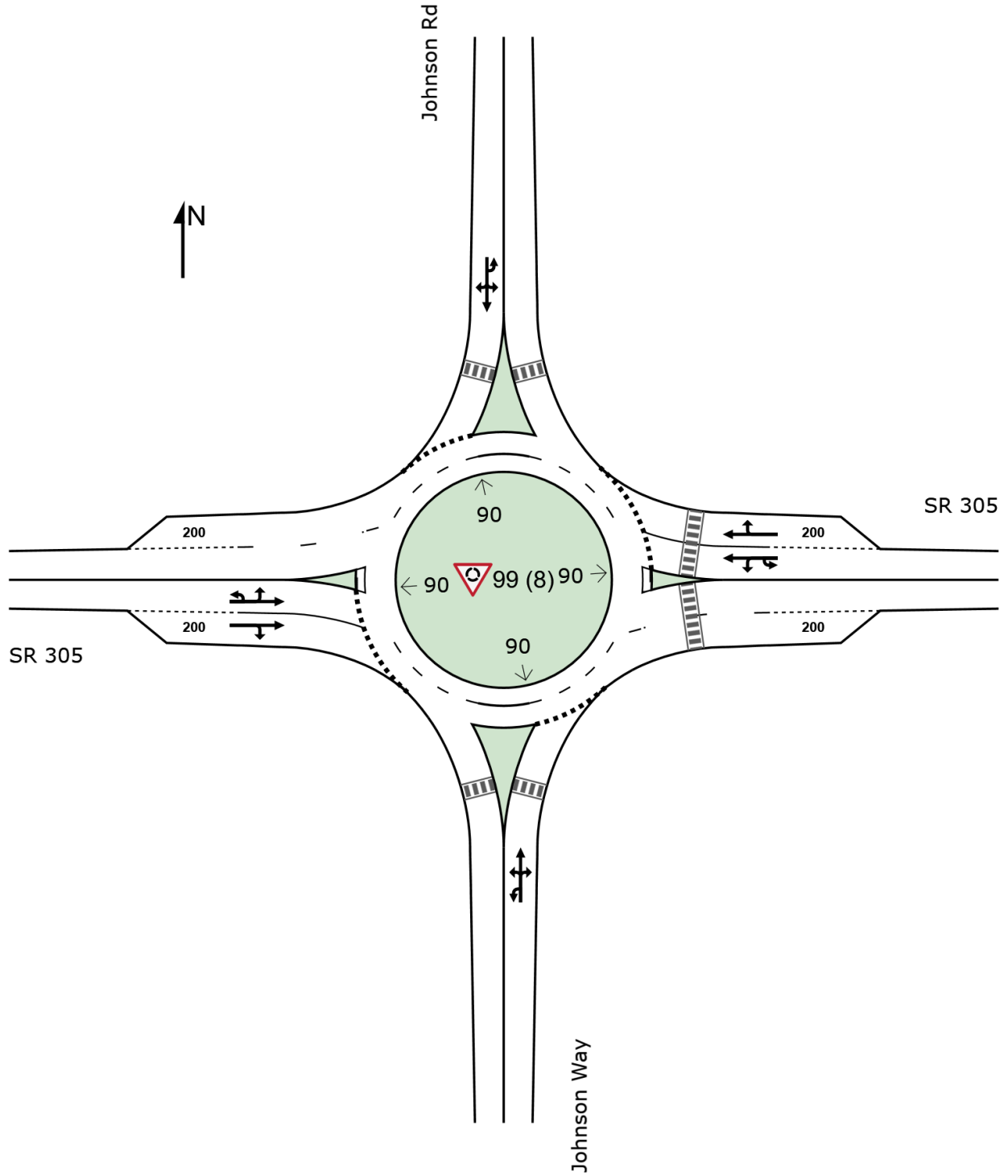

MOVEMENT SUMMARY

 Site: [1 (8)] Johnson & Sunrise Ridge - 2037 AM With (Folder1)

Output produced by SIDRA INTERSECTION Version: 10.0.9.250

New Site
 Site Category: (None)
 Roundabout
 Site Scenario: 1 | Local Volumes

Vehicle Movement Performance															
Mov ID	Turn	Mov Class	Demand Flows		Arrival Flows		Deg. Satn	Aver. Delay	Level of Service	95% Back Of Queue		Prop. Qued	Eff. Stop of Cycles	Number of Cycles	Aver. Speed
			[Total HV]	[Total HV]	[Total HV]	[Total HV]	v/c	sec		[Veh.]	[Dist]		Rate to Depart		mph
			veh/h	%	veh/h	%				veh	ft				
South: NE Midnight Sun Loop															
3u	U	All MCs	1	3.0	1	3.0	0.004	7.3	LOS A	0.0	0.4	0.21	0.45	0.21	23.4
3	L2	All MCs	1	3.0	1	3.0	0.004	5.9	LOS A	0.0	0.4	0.21	0.45	0.21	23.4
8	T1	All MCs	1	3.0	1	3.0	0.004	2.1	LOS A	0.0	0.4	0.21	0.45	0.21	23.6
18	R2	All MCs	1	3.0	1	3.0	0.004	2.5	LOS A	0.0	0.4	0.21	0.45	0.21	23.6
Approach			5	3.0	5	3.0	0.004	4.4	LOS A	0.0	0.4	0.21	0.45	0.21	23.5
East: Johnson Rd NE															
1u	U	All MCs	1	3.0	1	3.0	0.091	11.0	LOS B	0.4	9.9	0.15	0.46	0.15	34.5
1	L2	All MCs	1	3.0	1	3.0	0.091	9.1	LOS A	0.4	9.9	0.15	0.46	0.15	34.5
6	T1	All MCs	110	3.0	110	3.0	0.091	5.0	LOS A	0.4	9.9	0.15	0.46	0.15	35.2
16	R2	All MCs	6	3.0	6	3.0	0.091	4.8	LOS A	0.4	9.9	0.15	0.46	0.15	34.9
Approach			118	3.0	118	3.0	0.091	5.1	LOS A	0.4	9.9	0.15	0.46	0.15	35.1
North: Sunrise Ridge Ave NE															
7u	U	All MCs	1	3.0	1	3.0	0.118	11.4	LOS B	0.5	13.5	0.26	0.55	0.26	34.2
7	L2	All MCs	19	3.0	19	3.0	0.118	9.4	LOS A	0.5	13.5	0.26	0.55	0.26	34.2
4	T1	All MCs	1	3.0	1	3.0	0.118	5.4	LOS A	0.5	13.5	0.26	0.55	0.26	34.9
14	R2	All MCs	114	3.0	114	3.0	0.118	5.1	LOS A	0.5	13.5	0.26	0.55	0.26	34.5
Approach			136	3.0	136	3.0	0.118	5.8	LOS A	0.5	13.5	0.26	0.55	0.26	34.5
West: Johnson Rd NE															
5u	U	All MCs	1	3.0	1	3.0	0.069	10.9	LOS B	0.3	7.7	0.11	0.57	0.11	33.8
5	L2	All MCs	40	3.0	40	3.0	0.069	9.0	LOS A	0.3	7.7	0.11	0.57	0.11	33.8
2	T1	All MCs	33	3.0	33	3.0	0.069	4.9	LOS A	0.3	7.7	0.11	0.57	0.11	34.4
12	R2	All MCs	12	3.0	12	3.0	0.069	4.7	LOS A	0.3	7.7	0.11	0.57	0.11	34.1
Approach			87	3.0	87	3.0	0.069	6.9	LOS A	0.3	7.7	0.11	0.57	0.11	34.1
All Vehicles			345	3.0	345	3.0	0.118	5.8	LOS A	0.5	13.5	0.18	0.52	0.18	34.4

Site Level of Service (LOS) Method: Delay & Degree of Saturation (SIDRA). Site LOS Method is specified in the Parameter Settings dialog (Options tab).

Roundabout LOS Method: Same as Signalised Intersections.

Vehicle movement LOS values are based on average delay and v/c ratio (degree of saturation) per movement.

Intersection and Approach LOS values are based on average delay for all movements (v/c not used).

Roundabout Capacity Model: SIDRA HCM.

Delay Model: SIDRA Standard (Control Delay: Geometric Delay is included).

Queue Model: SIDRA queue estimation methods are used for Back of Queue and Queue at Start of Gap.

Gap-Acceptance Capacity Formula: SIDRA Standard (Akçelik M3D).

HV (%) values are calculated for All Movement Classes of All Heavy Vehicle Model Designation.

Arrival Flows used in performance calculations are adjusted to include any Initial Queued Demand and Upstream Capacity Constraint effects.

SITE LAYOUT

 Site: [1 (8)] Johnson & Sunrise Ridge - 2037 AM With (Folder1)

New Site
Site Category: (None)
Roundabout
Site Scenario: 1 | Local Volumes

Layout pictures are schematic functional drawings reflecting input data. They are not design drawings.

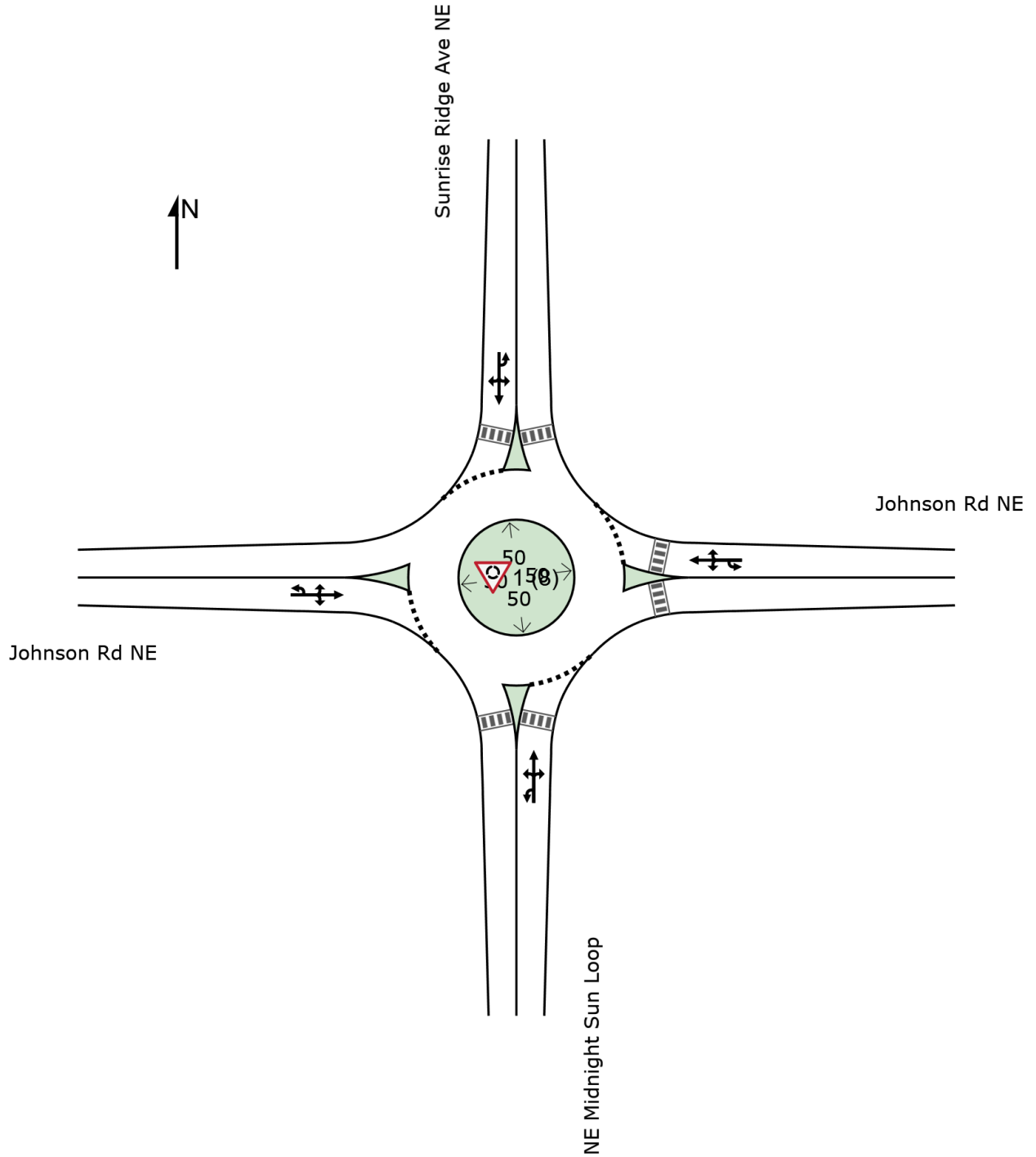

Intersection						
Int Delay, s/veh	6.4					
Movement	EBL	EBR	NBL	NBT	SBT	SBR
Lane Configurations	W			W	W	
Traffic Vol, veh/h	7	64	23	8	19	3
Future Vol, veh/h	7	64	23	8	19	3
Conflicting Peds, #/hr	0	0	0	0	0	0
Sign Control	Stop	Stop	Free	Free	Free	Free
RT Channelized	-	None	-	None	-	None
Storage Length	0	-	-	-	-	-
Veh in Median Storage, #	0	-	-	0	0	-
Grade, %	0	-	-	0	0	-
Peak Hour Factor	92	92	92	92	92	92
Heavy Vehicles, %	2	2	2	2	2	2
Mvmt Flow	8	70	25	9	21	3

Major/Minor	Minor2	Major1		Major2	
Conflicting Flow All	81	22	24	0	0
Stage 1	22	-	-	-	-
Stage 2	59	-	-	-	-
Critical Hdwy	6.42	6.22	4.12	-	-
Critical Hdwy Stg 1	5.42	-	-	-	-
Critical Hdwy Stg 2	5.42	-	-	-	-
Follow-up Hdwy	3.518	3.318	2.218	-	-
Pot Cap-1 Maneuver	921	1055	1591	-	-
Stage 1	1000	-	-	-	-
Stage 2	964	-	-	-	-
Platoon blocked, %				-	-
Mov Cap-1 Maneuver	907	1055	1591	-	-
Mov Cap-2 Maneuver	907	-	-	-	-
Stage 1	985	-	-	-	-
Stage 2	964	-	-	-	-

Approach	EB	NB	SB
HCM Ctrl Dly, s/v	8.75	5.42	0
HCM LOS	A		

Minor Lane/Major Mvmt	NBL	NBT	EBLn1	SBT	SBR
Capacity (veh/h)	1335	-	1038	-	-
HCM Lane V/C Ratio	0.016	-	0.074	-	-
HCM Ctrl Dly (s/v)	7.3	0	8.7	-	-
HCM Lane LOS	A	A	A	-	-
HCM 95th %tile Q(veh)	0	-	0.2	-	-

Intersection	
Intersection Delay, s/veh	63.2
Intersection LOS	F

Movement	EBL	EBT	EBR	WBL	WBT	WBR	NBL	NBT	NBR	SBL	SBT	SBR
Lane Configurations		↕			↕			↕			↕	↕
Traffic Vol, veh/h	58	285	28	27	257	97	73	48	53	157	32	73
Future Vol, veh/h	58	285	28	27	257	97	73	48	53	157	32	73
Peak Hour Factor	0.75	0.75	0.75	0.75	0.75	0.75	0.87	0.75	0.75	0.75	0.75	0.75
Heavy Vehicles, %	1	6	5	1	7	1	1	3	6	7	1	4
Mvmt Flow	77	380	37	36	343	129	84	64	71	209	43	97
Number of Lanes	0	1	0	0	1	0	0	1	0	0	1	1
Approach	EB			WB			NB			SB		
Opposing Approach	WB			EB			SB			NB		
Opposing Lanes	1			1			2			1		
Conflicting Approach Left	SB			NB			EB			WB		
Conflicting Lanes Left	2			1			1			1		
Conflicting Approach Right	NB			SB			WB			EB		
Conflicting Lanes Right	1			2			1			1		
HCM Control Delay, s/veh	84.3			86.9			22.7			24.1		
HCM LOS	F			F			C			C		

Lane	NBLn1	EBLn1	WBLn1	SBLn1	SBLn2
Vol Left, %	42%	16%	7%	83%	0%
Vol Thru, %	28%	77%	67%	17%	0%
Vol Right, %	30%	8%	25%	0%	100%
Sign Control	Stop	Stop	Stop	Stop	Stop
Traffic Vol by Lane	174	371	381	189	73
LT Vol	73	58	27	157	0
Through Vol	48	285	257	32	0
RT Vol	53	28	97	0	73
Lane Flow Rate	219	495	508	252	97
Geometry Grp	4a	2	2	5	5
Degree of Util (X)	0.537	1.049	1.06	0.645	0.216
Departure Headway (Hd)	9.35	7.965	7.817	9.661	8.392
Convergence, Y/N	Yes	Yes	Yes	Yes	Yes
Cap	389	460	467	375	430
Service Time	7.35	5.965	5.817	7.361	6.092
HCM Lane V/C Ratio	0.563	1.076	1.088	0.672	0.226
HCM Control Delay, s/veh	22.7	84.3	86.9	28.3	13.4
HCM Lane LOS	C	F	F	D	B
HCM 95th-tile Q	3.1	14.8	15.4	4.3	0.8

Intersection						
Int Delay, s/veh	4.2					
Movement	EBT	EBR	WBL	WBT	NBL	NBR
Lane Configurations						
Traffic Vol, veh/h	41	43	7	69	77	28
Future Vol, veh/h	41	43	7	69	77	28
Conflicting Peds, #/hr	0	10	10	0	10	10
Sign Control	Free	Free	Free	Free	Stop	Stop
RT Channelized	-	None	-	None	-	None
Storage Length	-	-	-	-	0	-
Veh in Median Storage, #	0	-	-	0	0	-
Grade, %	0	-	-	0	0	-
Peak Hour Factor	92	92	92	92	92	92
Heavy Vehicles, %	2	2	2	2	2	2
Mvmt Flow	45	47	8	75	84	30

Major/Minor	Major1	Major2	Minor1		
Conflicting Flow All	0	0	101	0	178 88
Stage 1	-	-	-	-	78 -
Stage 2	-	-	-	-	100 -
Critical Hdwy	-	-	4.12	-	6.42 6.22
Critical Hdwy Stg 1	-	-	-	-	5.42 -
Critical Hdwy Stg 2	-	-	-	-	5.42 -
Follow-up Hdwy	-	-	2.218	-	3.518 3.318
Pot Cap-1 Maneuver	-	-	1491	-	811 970
Stage 1	-	-	-	-	945 -
Stage 2	-	-	-	-	924 -
Platoon blocked, %	-	-	-	-	-
Mov Cap-1 Maneuver	-	-	1479	-	794 954
Mov Cap-2 Maneuver	-	-	-	-	794 -
Stage 1	-	-	-	-	937 -
Stage 2	-	-	-	-	911 -

Approach	EB	WB	NB
HCM Ctrl Dly, s/v	0	0.69	10.02
HCM LOS			B

Minor Lane/Major Mvmt	NBLn1	EBT	EBR	WBL	WBT
Capacity (veh/h)	831	-	-	166	-
HCM Lane V/C Ratio	0.137	-	-	0.005	-
HCM Ctrl Dly (s/v)	10	-	-	7.4	0
HCM Lane LOS	B	-	-	A	A
HCM 95th %tile Q(veh)	0.5	-	-	0	-

HCM 7th Signalized Intersection Summary
1: SR305 & NE Hostmark St

Forecast 2037 PM Peak Hour
With Project

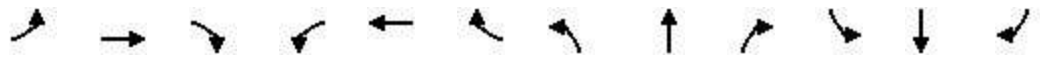

Movement	EBL	EBT	EBR	WBL	WBT	WBR	NBL	NBT	NBR	SBL	SBT	SBR
Lane Configurations												
Traffic Volume (veh/h)	86	212	139	66	156	277	159	877	43	266	719	62
Future Volume (veh/h)	86	212	139	66	156	277	159	877	43	266	719	62
Initial Q (Qb), veh	0	0	0	0	0	0	0	0	0	0	0	0
Lane Width Adj.	1.00	1.00	1.00	1.00	1.00	1.00	1.00	1.00	1.00	1.00	1.00	1.00
Ped-Bike Adj(A_pbT)	0.99		0.97	0.99		0.96	1.00		0.96	1.00		0.97
Parking Bus, Adj	1.00	1.00	1.00	1.00	1.00	1.00	1.00	1.00	1.00	1.00	1.00	1.00
Work Zone On Approach		No			No			No			No	
Adj Sat Flow, veh/h/ln	1702	1758	1786	1786	1786	1786	1772	1744	1786	1786	1772	1744
Adj Flow Rate, veh/h	86	212	139	66	156	132	159	877	43	266	719	62
Peak Hour Factor	1.00	1.00	1.00	1.00	1.00	1.00	1.00	1.00	1.00	1.00	1.00	1.00
Percent Heavy Veh, %	7	3	1	1	1	1	2	4	1	1	2	4
Cap, veh/h	196	250	208	155	228	186	182	932	46	542	1487	128
Arrive On Green	0.06	0.14	0.14	0.04	0.13	0.13	0.11	0.33	0.33	0.32	0.54	0.54
Sat Flow, veh/h	1621	1758	1463	1701	1786	1459	1688	2813	138	1701	2743	236
Grp Volume(v), veh/h	86	212	139	66	156	132	159	386	534	266	330	451
Grp Sat Flow(s),veh/h/ln	1621	1758	1463	1701	1786	1459	1688	1238	1713	1701	1258	1721
Q Serve(g_s), s	5.5	14.1	10.8	4.0	10.0	5.7	11.1	36.3	36.4	15.2	19.5	19.5
Cycle Q Clear(g_c), s	5.5	14.1	10.8	4.0	10.0	5.7	11.1	36.3	36.4	15.2	19.5	19.5
Prop In Lane	1.00		1.00	1.00		1.00	1.00		0.08	1.00		0.14
Lane Grp Cap(c), veh/h	196	250	208	155	228	186	182	410	567	542	682	933
V/C Ratio(X)	0.44	0.85	0.67	0.42	0.69	0.71	0.87	0.94	0.94	0.49	0.48	0.48
Avail Cap(c_a), veh/h	316	337	280	306	342	280	323	444	614	542	682	933
HCM Platoon Ratio	1.00	1.00	1.00	1.00	1.00	1.00	1.00	1.00	1.00	1.00	1.00	1.00
Upstream Filter(I)	1.00	1.00	1.00	1.00	1.00	1.00	1.00	1.00	1.00	1.00	1.00	1.00
Uniform Delay (d), s/veh	42.7	50.2	48.8	43.8	50.0	15.1	52.7	39.0	39.0	33.0	17.0	17.0
Incr Delay (d2), s/veh	1.5	14.1	3.7	1.8	3.6	4.9	12.3	31.9	25.7	0.7	2.4	1.8
Initial Q Delay(d3), s/veh	0.0	0.0	0.0	0.0	0.0	0.0	0.0	0.0	0.0	0.0	0.0	0.0
%ile BackOfQ(95%),veh/ln	4.1	11.6	7.5	3.2	8.3	7.0	9.0	20.4	25.9	10.3	9.7	12.3
Unsig. Movement Delay, s/veh												
LnGrp Delay(d), s/veh	44.3	64.3	52.5	45.7	53.7	20.0	65.0	70.8	64.7	33.7	19.5	18.8
LnGrp LOS	D	E	D	D	D	C	E	E	E	C	B	B
Approach Vol, veh/h		437			354			1079			1047	
Approach Delay, s/veh		56.6			39.6			67.0			22.8	
Approach LOS		E			D			E			C	
Timer - Assigned Phs	1	2	3	4	5	6	7	8				
Phs Duration (G+Y+Rc), s	43.3	44.7	10.0	22.0	17.9	70.1	11.7	20.3				
Change Period (Y+Rc), s	4.5	4.5	4.5	4.5	4.5	4.5	4.5	4.5				
Max Green Setting (Gmax), s	18.9	43.5	16.1	23.5	23.5	38.9	16.1	23.5				
Max Q Clear Time (g_c+I1), s	17.2	38.4	6.0	16.1	13.1	21.5	7.5	12.0				
Green Ext Time (p_c), s	0.2	1.9	0.1	0.9	0.4	3.0	0.1	0.9				
Intersection Summary												
HCM 7th Control Delay, s/veh			46.2									
HCM 7th LOS			D									

Intersection						
Int Delay, s/veh	0.1					
Movement	EBL	EBT	WBT	WBR	SBL	SBR
Lane Configurations	↖	↗	↗	↖	↖	↖
Traffic Vol, veh/h	7	869	988	6	1	4
Future Vol, veh/h	7	869	988	6	1	4
Conflicting Peds, #/hr	1	0	0	1	1	1
Sign Control	Free	Free	Free	Free	Stop	Stop
RT Channelized	-	None	-	None	-	None
Storage Length	105	-	-	55	60	0
Veh in Median Storage, #	-	0	0	-	0	-
Grade, %	-	0	0	-	0	-
Peak Hour Factor	100	100	100	100	100	100
Heavy Vehicles, %	10	2	3	1	10	1
Mvmt Flow	7	869	988	6	1	4

Major/Minor	Major1	Major2	Minor2		
Conflicting Flow All	995	0	-	0	1873 990
Stage 1	-	-	-	-	989 -
Stage 2	-	-	-	-	884 -
Critical Hdwy	4.2	-	-	-	6.5 6.21
Critical Hdwy Stg 1	-	-	-	-	5.5 -
Critical Hdwy Stg 2	-	-	-	-	5.5 -
Follow-up Hdwy	2.29	-	-	-	3.59 3.309
Pot Cap-1 Maneuver	665	-	-	-	75 300
Stage 1	-	-	-	-	348 -
Stage 2	-	-	-	-	391 -
Platoon blocked, %		-	-	-	
Mov Cap-1 Maneuver	664	-	-	-	74 300
Mov Cap-2 Maneuver	-	-	-	-	74 -
Stage 1	-	-	-	-	344 -
Stage 2	-	-	-	-	391 -

Approach	EB	WB	SB
HCM Ctrl Dly, s/v	0.08	0	24.55
HCM LOS			C

Minor Lane/Major Mvmt	EBL	EBT	WBT	WBR	SBLn1	SBLn2
Capacity (veh/h)	664	-	-	-	74	300
HCM Lane V/C Ratio	0.011	-	-	-	0.013	0.013
HCM Ctrl Dly (s/v)	10.5	-	-	-	54.1	17.2
HCM Lane LOS	B	-	-	-	F	C
HCM 95th %tile Q(veh)	0	-	-	-	0	0

MOVEMENT SUMMARY

 Site: [99 (10)] SR 305 & Johnson Rd - Forecast 2037 With (PM Peak Hour)

Output produced by SIDRA INTERSECTION Version: 10.0.9.250

New Site
 Site Category: (None)
 Roundabout
Site Scenario: 1 | Local Volumes

Vehicle Movement Performance															
Mov ID	Turn	Mov Class	Demand Flows		Arrival Flows		Deg. Satn	Aver. Delay	Level of Service	95% Back Of Queue		Prop. Qued	Eff. Stop Rate	Number of Cycles to Depart	Aver. Speed
			[Total HV]	[Total HV]	[Total HV]	[Total HV]	v/c	sec		[Veh.]	[Dist]				mph
			veh/h	%	veh/h	%				veh	ft				
South: Johnson Way															
3u	U	All MCs	1	1.0	1	1.0	0.063	15.0	LOS B	0.2	6.3	0.58	0.75	0.58	31.1
3	L2	All MCs	25	6.0	25	6.0	0.063	12.0	LOS B	0.2	6.3	0.58	0.75	0.58	32.2
8	T1	All MCs	7	1.0	7	1.0	0.063	5.9	LOS A	0.2	6.3	0.58	0.75	0.58	30.3
18	R2	All MCs	10	1.0	10	1.0	0.063	8.2	LOS A	0.2	6.3	0.58	0.75	0.58	33.3
Approach			43	3.9	43	3.9	0.063	10.2	LOS B	0.2	6.3	0.58	0.75	0.58	32.1
East: SR 305															
1u	U	All MCs	3	1.0	3	1.0	0.496	12.3	LOS B	3.8	97.2	0.32	0.47	0.32	37.2
1	L2	All MCs	13	1.0	13	1.0	0.496	11.7	LOS B	3.8	97.2	0.32	0.47	0.32	35.3
6	T1	All MCs	934	3.0	934	3.0	0.496	6.6	LOS A	3.8	97.2	0.30	0.47	0.30	40.7
16	R2	All MCs	59	10.0	59	10.0	0.225	6.3	LOS A	1.2	32.0	0.27	0.49	0.27	35.6
Approach			1009	3.4	1009	3.4	0.496	6.7	LOS A	3.8	97.2	0.30	0.47	0.30	40.3
North: Johnson Rd															
7u	U	All MCs	1	1.0	1	1.0	0.146	15.7	LOS B	0.6	15.6	0.63	0.77	0.63	30.7
7	L2	All MCs	53	6.0	53	6.0	0.146	12.8	LOS B	0.6	15.6	0.63	0.77	0.63	32.0
4	T1	All MCs	4	1.0	4	1.0	0.146	6.6	LOS A	0.6	15.6	0.63	0.77	0.63	30.0
14	R2	All MCs	37	1.0	37	1.0	0.146	9.6	LOS A	0.6	15.6	0.63	0.77	0.63	33.0
Approach			95	3.8	95	3.8	0.146	11.3	LOS B	0.6	15.6	0.63	0.77	0.63	32.3
West: SR 305															
5u	U	All MCs	1	1.0	1	1.0	0.425	12.2	LOS B	3.2	81.6	0.30	0.48	0.30	37.1
5	L2	All MCs	47	1.0	47	1.0	0.425	11.7	LOS B	3.2	81.6	0.30	0.48	0.30	35.2
2	T1	All MCs	804	2.0	804	2.0	0.425	6.4	LOS A	3.2	81.6	0.29	0.48	0.29	40.8
12	R2	All MCs	25	1.0	25	1.0	0.193	6.0	LOS A	1.1	27.7	0.26	0.47	0.26	35.9
Approach			877	1.9	877	1.9	0.425	6.7	LOS A	3.2	81.6	0.29	0.48	0.29	40.3
All Vehicles			2024	2.8	2024	2.8	0.496	7.0	LOS A	3.8	97.2	0.32	0.49	0.32	39.6

Site Level of Service (LOS) Method: Delay & Degree of Saturation (SIDRA). Site LOS Method is specified in the Parameter Settings dialog (Options tab).

Roundabout LOS Method: Same as Signalised Intersections.

Vehicle movement LOS values are based on average delay and v/c ratio (degree of saturation) per movement.

Intersection and Approach LOS values are based on average delay for all movements (v/c not used).

Roundabout Capacity Model: SIDRA HCM.

Delay Model: SIDRA Standard (Control Delay: Geometric Delay is included).

Queue Model: SIDRA queue estimation methods are used for Back of Queue and Queue at Start of Gap.

Gap-Acceptance Capacity Formula: SIDRA Standard (Akçelik M3D).

HV (%) values are calculated for All Movement Classes of All Heavy Vehicle Model Designation.

Arrival Flows used in performance calculations are adjusted to include any Initial Queued Demand and Upstream Capacity Constraint effects.

SITE LAYOUT

 Site: [99 (10)] SR 305 & Johnson Rd - Forecast 2037 With (PM Peak Hour)

New Site
Site Category: (None)
Roundabout
Site Scenario: 1 | Local Volumes

Layout pictures are schematic functional drawings reflecting input data. They are not design drawings.

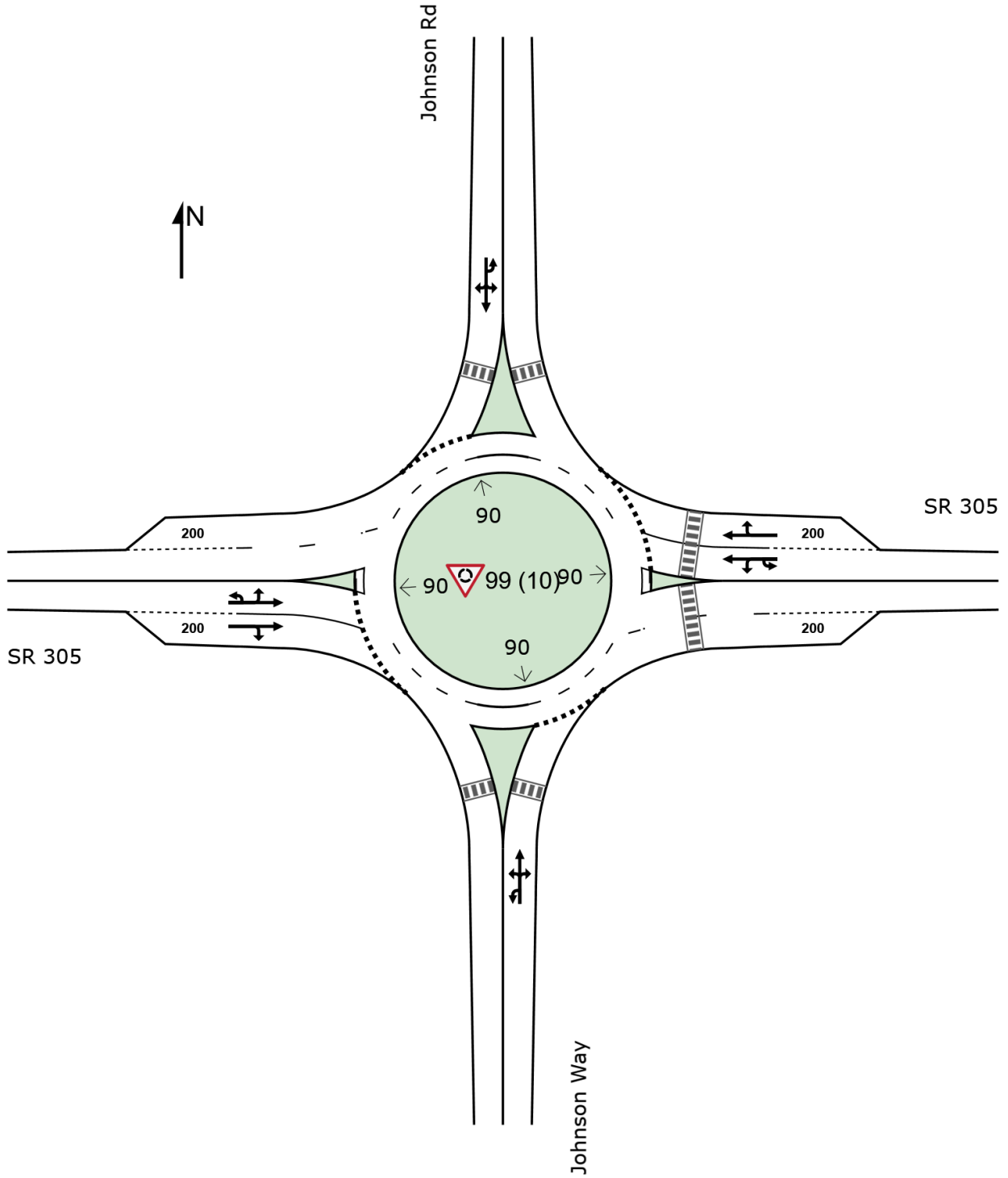

MOVEMENT SUMMARY

 Site: [1 (10)] Johnson & Sunrise Ridge - 2037 PM With (Folder1)

Output produced by SIDRA INTERSECTION Version: 10.0.9.250

New Site
 Site Category: (None)
 Roundabout
Site Scenario: 1 | Local Volumes

Vehicle Movement Performance															
Mov ID	Turn	Mov Class	Demand Flows		Arrival Flows		Deg. Satn	Aver. Delay	Level of Service	95% Back Of Queue		Prop. Qued	Eff. Stop Rate	Number of Cycles to Depart	Aver. Speed
			[Total HV]	[Total HV]	[Total HV]	[Total HV]	v/c	sec		[Veh.]	[Dist]				mph
			veh/h	%	veh/h	%				veh	ft				
South: NE Midnight Sun Loop															
3u	U	All MCs	1	3.0	1	3.0	0.007	7.5	LOS A	0.0	0.7	0.26	0.43	0.26	23.6
3	L2	All MCs	1	3.0	1	3.0	0.007	6.1	LOS A	0.0	0.7	0.26	0.43	0.26	23.6
8	T1	All MCs	1	3.0	1	3.0	0.007	2.3	LOS A	0.0	0.7	0.26	0.43	0.26	23.8
18	R2	All MCs	5	3.0	5	3.0	0.007	2.7	LOS A	0.0	0.7	0.26	0.43	0.26	23.7
Approach			8	3.0	8	3.0	0.007	3.8	LOS A	0.0	0.7	0.26	0.43	0.26	23.7
East: Johnson Rd NE															
1u	U	All MCs	1	3.0	1	3.0	0.059	11.2	LOS B	0.2	6.3	0.23	0.50	0.23	34.2
1	L2	All MCs	5	3.0	5	3.0	0.059	9.3	LOS A	0.2	6.3	0.23	0.50	0.23	34.2
6	T1	All MCs	50	3.0	50	3.0	0.059	5.3	LOS A	0.2	6.3	0.23	0.50	0.23	34.9
16	R2	All MCs	17	3.0	17	3.0	0.059	5.0	LOS A	0.2	6.3	0.23	0.50	0.23	34.6
Approach			73	3.0	73	3.0	0.059	5.6	LOS A	0.2	6.3	0.23	0.50	0.23	34.7
North: Sunrise Ridge Ave NE															
7u	U	All MCs	1	3.0	1	3.0	0.070	11.1	LOS B	0.3	7.8	0.18	0.53	0.18	34.4
7	L2	All MCs	9	3.0	9	3.0	0.070	9.1	LOS A	0.3	7.8	0.18	0.53	0.18	34.4
4	T1	All MCs	1	3.0	1	3.0	0.070	5.1	LOS A	0.3	7.8	0.18	0.53	0.18	35.1
14	R2	All MCs	73	3.0	73	3.0	0.070	4.8	LOS A	0.3	7.8	0.18	0.53	0.18	34.8
Approach			84	3.0	84	3.0	0.070	5.4	LOS A	0.3	7.8	0.18	0.53	0.18	34.7
West: Johnson Rd NE															
5u	U	All MCs	1	3.0	1	3.0	0.106	10.9	LOS B	0.5	11.8	0.09	0.62	0.09	33.2
5	L2	All MCs	107	3.0	107	3.0	0.106	8.9	LOS A	0.5	11.8	0.09	0.62	0.09	33.2
2	T1	All MCs	26	3.0	26	3.0	0.106	4.9	LOS A	0.5	11.8	0.09	0.62	0.09	33.8
12	R2	All MCs	1	3.0	1	3.0	0.106	4.7	LOS A	0.5	11.8	0.09	0.62	0.09	33.5
Approach			135	3.0	135	3.0	0.106	8.1	LOS A	0.5	11.8	0.09	0.62	0.09	33.3
All Vehicles			300	3.0	300	3.0	0.106	6.6	LOS A	0.5	11.8	0.15	0.56	0.15	33.7

Site Level of Service (LOS) Method: Delay & Degree of Saturation (SIDRA). Site LOS Method is specified in the Parameter Settings dialog (Options tab).

Roundabout LOS Method: Same as Signalised Intersections.

Vehicle movement LOS values are based on average delay and v/c ratio (degree of saturation) per movement.

Intersection and Approach LOS values are based on average delay for all movements (v/c not used).

Roundabout Capacity Model: SIDRA HCM.

Delay Model: SIDRA Standard (Control Delay: Geometric Delay is included).

Queue Model: SIDRA queue estimation methods are used for Back of Queue and Queue at Start of Gap.

Gap-Acceptance Capacity Formula: SIDRA Standard (Akçelik M3D).

HV (%) values are calculated for All Movement Classes of All Heavy Vehicle Model Designation.

Arrival Flows used in performance calculations are adjusted to include any Initial Queued Demand and Upstream Capacity Constraint effects.

SITE LAYOUT

 Site: [1 (10)] Johnson & Sunrise Ridge - 2037 PM With (Folder1)

New Site
Site Category: (None)
Roundabout
Site Scenario: 1 | Local Volumes

Layout pictures are schematic functional drawings reflecting input data. They are not design drawings.

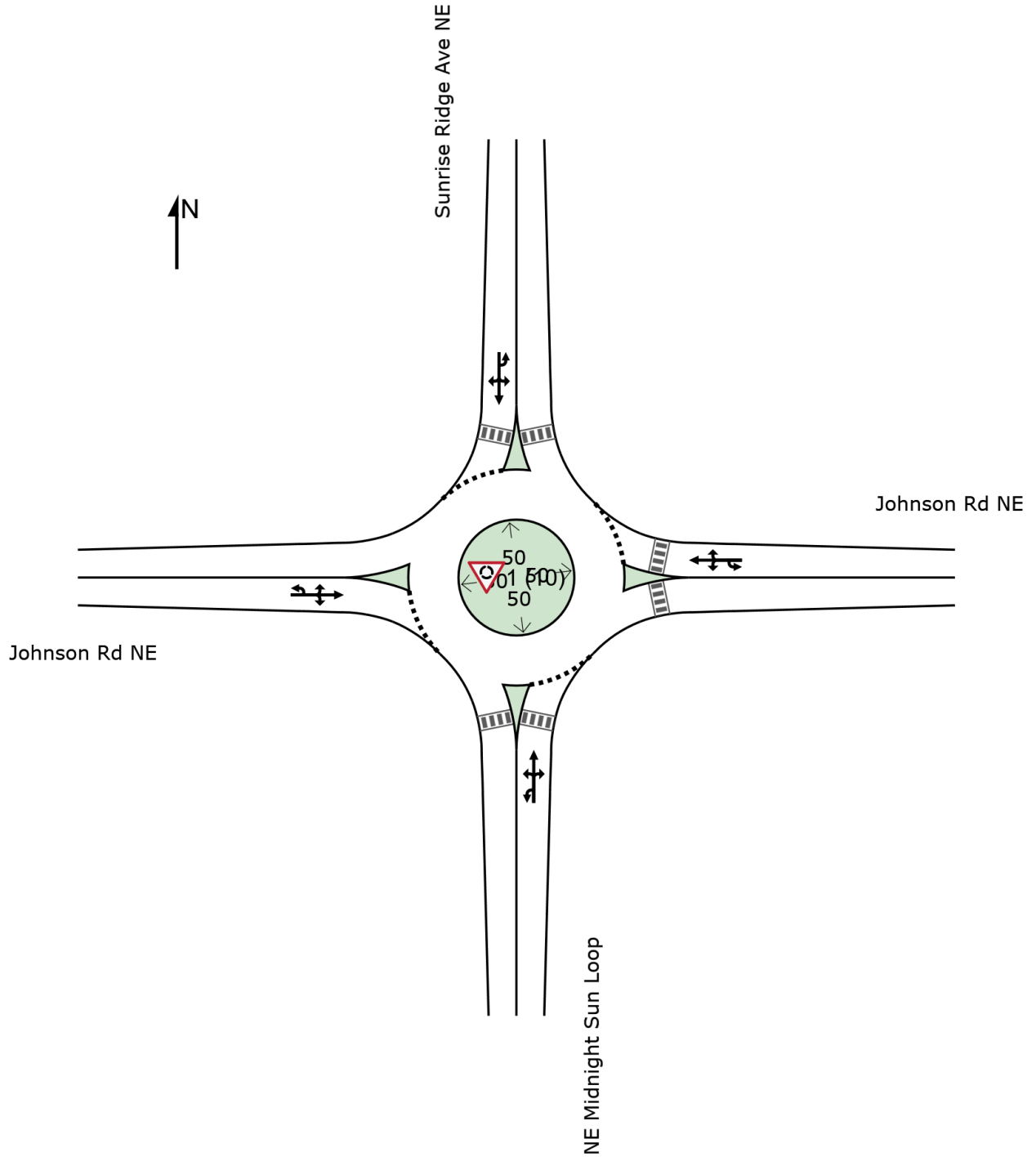

Intersection						
Int Delay, s/veh	6.5					
Movement	EBL	EBR	NBL	NBT	SBT	SBR
Lane Configurations						
Traffic Vol, veh/h	5	43	72	7	12	8
Future Vol, veh/h	5	43	72	7	12	8
Conflicting Peds, #/hr	0	0	0	0	0	0
Sign Control	Stop	Stop	Free	Free	Free	Free
RT Channelized	-	None	-	None	-	None
Storage Length	0	-	-	-	-	-
Veh in Median Storage, #	0	-	-	0	0	-
Grade, %	0	-	-	0	0	-
Peak Hour Factor	92	92	92	92	92	92
Heavy Vehicles, %	2	2	2	2	2	2
Mvmt Flow	5	47	78	8	13	9

Major/Minor	Minor2	Major1		Major2	
Conflicting Flow All	182	17	22	0	0
Stage 1	17	-	-	-	-
Stage 2	164	-	-	-	-
Critical Hdwy	6.42	6.22	4.12	-	-
Critical Hdwy Stg 1	5.42	-	-	-	-
Critical Hdwy Stg 2	5.42	-	-	-	-
Follow-up Hdwy	3.518	3.318	2.218	-	-
Pot Cap-1 Maneuver	808	1061	1594	-	-
Stage 1	1005	-	-	-	-
Stage 2	865	-	-	-	-
Platoon blocked, %				-	-
Mov Cap-1 Maneuver	768	1061	1594	-	-
Mov Cap-2 Maneuver	768	-	-	-	-
Stage 1	956	-	-	-	-
Stage 2	865	-	-	-	-

Approach	EB	NB	SB
HCM Ctrl Dly, s/v	8.72	6.72	0
HCM LOS	A		

Minor Lane/Major Mvmt	NBL	NBT	EBLn1	SBT	SBR
Capacity (veh/h)	1587	-	1021	-	-
HCM Lane V/C Ratio	0.049	-	0.051	-	-
HCM Ctrl Dly (s/v)	7.4	0	8.7	-	-
HCM Lane LOS	A	A	A	-	-
HCM 95th %tile Q(veh)	0.2	-	0.2	-	-

Intersection	
Intersection Delay, s/veh	27.1
Intersection LOS	D

Movement	EBL	EBT	EBR	WBL	WBT	WBR	NBL	NBT	NBR	SBL	SBT	SBR
Lane Configurations		↕			↕			↕			↕	↕
Traffic Vol, veh/h	108	264	87	15	166	60	78	62	6	111	79	79
Future Vol, veh/h	108	264	87	15	166	60	78	62	6	111	79	79
Peak Hour Factor	0.87	0.87	0.87	0.87	0.87	0.87	0.87	0.87	0.87	0.87	0.87	0.87
Heavy Vehicles, %	3	1	1	1	1	2	1	1	1	1	1	4
Mvmt Flow	124	303	100	17	191	69	90	71	7	128	91	91
Number of Lanes	0	1	0	0	1	0	0	1	0	0	1	1

Approach	EB	WB	NB	SB
Opposing Approach	WB	EB	SB	NB
Opposing Lanes	1	1	2	1
Conflicting Approach Left	SB	NB	EB	WB
Conflicting Lanes Left	2	1	1	1
Conflicting Approach Right	NB	SB	WB	EB
Conflicting Lanes Right	1	2	1	1
HCM Control Delay, s/veh	43.3	16.6	14.8	15.6
HCM LOS	E	C	B	C

Lane	NBLn1	EBLn1	WBLn1	SBLn1	SBLn2
Vol Left, %	53%	24%	6%	58%	0%
Vol Thru, %	42%	58%	69%	42%	0%
Vol Right, %	4%	19%	25%	0%	100%
Sign Control	Stop	Stop	Stop	Stop	Stop
Traffic Vol by Lane	146	459	241	190	79
LT Vol	78	108	15	111	0
Through Vol	62	264	166	79	0
RT Vol	6	87	60	0	79
Lane Flow Rate	168	528	277	218	91
Geometry Grp	4a	2	2	5	5
Degree of Util (X)	0.357	0.908	0.511	0.473	0.171
Departure Headway (Hd)	7.655	6.194	6.64	7.793	6.773
Convergence, Y/N	Yes	Yes	Yes	Yes	Yes
Cap	473	580	537	461	526
Service Time	5.655	4.272	4.737	5.585	4.564
HCM Lane V/C Ratio	0.355	0.91	0.516	0.473	0.173
HCM Control Delay, s/veh	14.8	43.3	16.6	17.5	11
HCM Lane LOS	B	E	C	C	B
HCM 95th-tile Q	1.6	11.1	2.9	2.5	0.6

Intersection						
Int Delay, s/veh	3.1					
Movement	EBT	EBR	WBL	WBT	NBL	NBR
Lane Configurations						
Traffic Vol, veh/h	69	82	28	69	53	21
Future Vol, veh/h	69	82	28	69	53	21
Conflicting Peds, #/hr	0	10	10	0	10	10
Sign Control	Free	Free	Free	Free	Stop	Stop
RT Channelized	-	None	-	None	-	None
Storage Length	-	-	-	-	0	-
Veh in Median Storage, #	0	-	-	0	0	-
Grade, %	0	-	-	0	0	-
Peak Hour Factor	92	92	92	92	92	92
Heavy Vehicles, %	2	2	2	2	2	2
Mvmt Flow	75	89	30	75	58	23

Major/Minor	Major1	Major2	Minor1		
Conflicting Flow All	0	0	174	0	275
Stage 1	-	-	-	-	130
Stage 2	-	-	-	-	146
Critical Hdwy	-	-	4.12	-	6.42
Critical Hdwy Stg 1	-	-	-	-	5.42
Critical Hdwy Stg 2	-	-	-	-	5.42
Follow-up Hdwy	-	-	2.218	-	3.518
Pot Cap-1 Maneuver	-	-	1402	-	714
Stage 1	-	-	-	-	896
Stage 2	-	-	-	-	881
Platoon blocked, %	-	-	-	-	-
Mov Cap-1 Maneuver	-	-	1391	-	686
Mov Cap-2 Maneuver	-	-	-	-	686
Stage 1	-	-	-	-	889
Stage 2	-	-	-	-	854

Approach	EB	WB	NB
HCM Ctrl Dly, s/v	0	2.21	10.5
HCM LOS			B

Minor Lane/Major Mvmt	NBLn1	EBT	EBR	WBL	WBT
Capacity (veh/h)	735	-	-	520	-
HCM Lane V/C Ratio	0.109	-	-	0.022	-
HCM Ctrl Dly (s/v)	10.5	-	-	7.6	0
HCM Lane LOS	B	-	-	A	A
HCM 95th %tile Q(veh)	0.4	-	-	0.1	-

THE PINNACLE AT LIBERTY BAY TRAFFIC IMPACT ANALYSIS

APPENDIX Site Plan



TRACT AREA TABLE				TRACT AREA TABLE			
TRACT	USE	OWNERSHIP	AREA (SF)	TRACT	USE	OWNERSHIP	AREA (SF)
A	CRITICAL AREA	HOA	589,600	N	ACCESS/UTILITY	HOA	3,026
B	CRITICAL AREA	HOA	6,842	O	ACCESS/UTILITY	HOA	820
C	CRITICAL AREA	HOA	135,518	P	ACCESS/UTILITY	HOA	3,528
D	CRITICAL AREA	HOA	28,901	Q	OPEN SPACE	HOA	10,287
E	STORMWATER	CITY	89,997	R	OPEN SPACE	HOA	2,535
F	STORMWATER/OPEN SPACE	HOA	17,635	S	OPEN SPACE	HOA	35,393
G	ACCESS/UTILITY	HOA	2,761	T	RECREATION	HOA	10,568
H	ACCESS/UTILITY	HOA	3,453	U	RECREATION	HOA	9,258
I	ACCESS/UTILITY	HOA	2,278	V	RECREATION	HOA	4,592
J	ACCESS/UTILITY	HOA	1,535	W	RECREATION	HOA	13,055
K	ACCESS/UTILITY	HOA	2,055	X	RECREATION	HOA	5,871
L	ACCESS/UTILITY	HOA	3,681	Y	RECREATION	HOA	5,288
M	ACCESS/UTILITY	HOA	4,062				

A PORTION OF THE SE 1/4 OF SECTION 23, TWP. 26 N., RGE. 1 E., WM

LOT AREA TABLE		LOT AREA TABLE		LOT AREA TABLE		LOT AREA TABLE		LOT AREA TABLE		LOT AREA TABLE		LOT AREA TABLE		LOT AREA TABLE		LOT AREA TABLE		LOT AREA TABLE		LOT AREA TABLE		LOT AREA TABLE	
LOT #	AREA (SF)	LOT #	AREA (SF)	LOT #	AREA (SF)	LOT #	AREA (SF)	LOT #	AREA (SF)	LOT #	AREA (SF)	LOT #	AREA (SF)	LOT #	AREA (SF)	LOT #	AREA (SF)	LOT #	AREA (SF)	LOT #	AREA (SF)	LOT #	AREA (SF)
1	4,108	13	4,085	26	4,476	38	3,870	50	6,316	62	6,277	74	4,100	86	4,100	98	4,530	110	4,567	122	4,100	134	4,326
2	4,023	14	3,917	27	4,015	39	3,870	51	4,521	63	5,079	75	4,100	87	4,100	99	6,141	111	4,584	123	4,100	135	4,504
3	4,237	15	4,330	28	3,916	40	4,420	52	4,614	64	5,926	76	4,613	88	4,100	100	4,058	112	4,158	124	4,426	136	4,110
4	4,313	16	5,088	29	5,408	41	4,429	53	4,871	65	5,037	77	4,200	89	4,100	101	4,100	113	4,100	125	4,949	137	4,100
5	8,715	17	4,518	30	3,937	42	4,427	54	5,209	66	4,477	78	4,200	90	4,100	102	4,100	114	4,100	126	4,900	138	4,900
6	4,265	19	4,345	31	3,762	43	4,425	55	3,832	67	4,477	79	4,374	91	4,100	103	4,100	115	4,100	127	6,996		
7	4,408	20	4,345	32	3,763	44	5,015	56	4,433	68	6,270	80	5,825	92	4,100	104	4,100	116	4,100	128	4,605		
8	4,049	21	5,185	33	3,763	45	3,903	57	3,898	69	4,098	81	6,303	93	4,100	105	4,100	117	4,100	129	5,206		
9	3,850	22	6,353	34	3,762	46	3,757	58	4,581	70	4,100	82	5,274	94	4,058	106	4,020	118	4,072	130	4,099		
10	4,050	23	5,122	35	3,788	47	3,756	59	4,551	71	4,100	83	4,439	95	4,440	107	6,014	119	4,100	131	4,100		
11	3,709	24	4,786	36	3,870	48	3,996	60	4,086	72	4,100	84	4,100	96	4,010	108	4,100	120	4,100	132	4,100		
12	3,838	25	4,680	37	3,870	49	4,461	61	5,404	73	4,100	85	4,100	97	4,037	109	4,109	121	4,100	133	4,107		

REVISIONS		
NO.	DESCRIPTION/DATE	BY

BRANDON MICHAEL LOOIS
 REGISTERED PROFESSIONAL ENGINEER
 No. 50085
 STATE OF WASHINGTON

ESM CONSULTING ENGINEERS, LLC
 33400 8th Ave S, Suite 205
 Federal Way, WA 98003
 www.esmcivil.com

Civil Engineering | Land Surveying | Project Management | Landscape Architecture
 Public Works | Land Planning | Landscape Architecture



BUILDING SETBACKS

REAR:	10'
FRONT:	20'
SIDE:	5'
STREET SIDE:	10'
STREAM:	25'
WETLAND:	15'

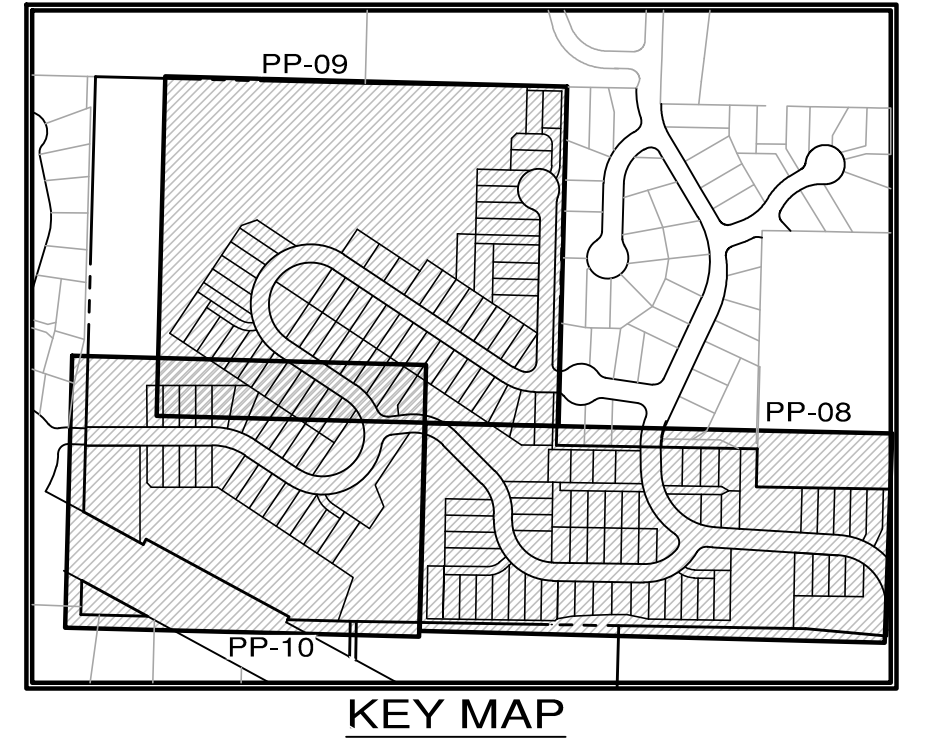
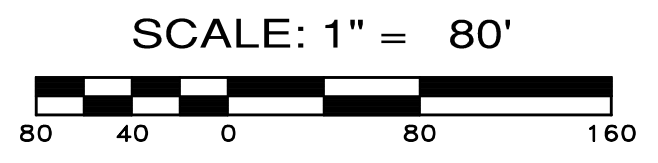

LEGEND

	BUILDING SETBACK LINE
	LOT LINE/TRACT LINE
	RIGHT OF WAY LINE
	PROPOSED EASEMENT
	MONUMENT
	CRITICAL AREA BUFFER
	WETLAND
	PHASE 1
	PHASE 2
	PHASE 3
	PRELIMINARY HOUSE FOOTPRINTS

File: \\Esm\eng\ESM-JOB\0004\004\002\004\002\004\002\004\002\004.dwg
 Plotter: 2/23/2024, 3:36 PM
 Printed By: Don Lipp

MONTEBANC MANAGEMENT, LLC
PINNACLE AT LIBERTY BAY SUBDIVISION
 OVERALL SITE PLAN & LOT/TRACT PHASING PLAN
 CITY OF POULSBORO WASHINGTON

JOB NO.:	2090-004-022
DWG. NAME:	PP-07
DESIGNED BY:	
DRAWN BY:	
CHECKED BY:	
DATE:	11/26/2025
DATE OF PRINT:	

PP-07
 7 OF 33 SHEETS